

Mechlift Pro 150/250

Electric

Original instructions
2015-06-01

EN
CE

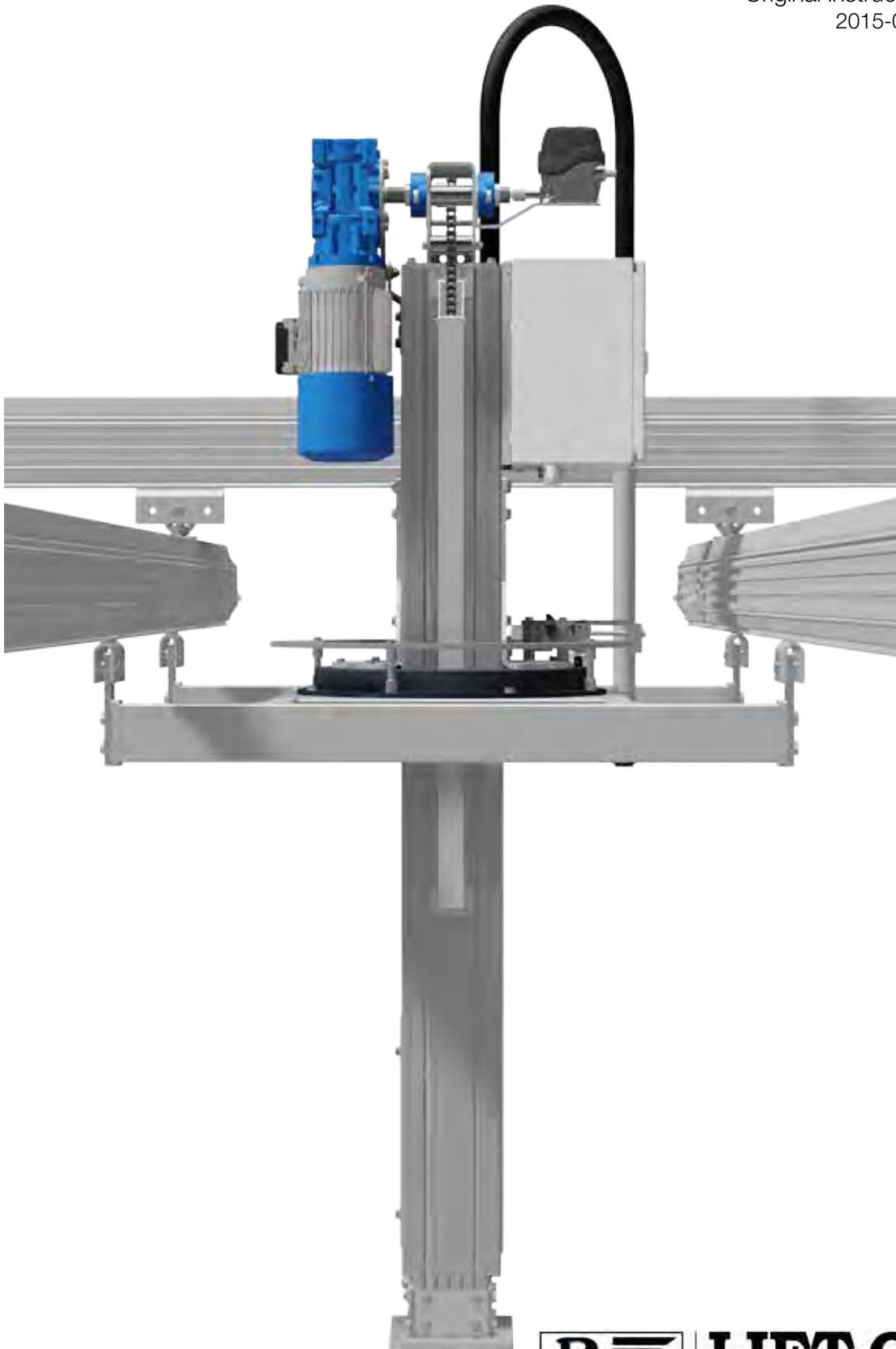

LIFT-O-FLEX

MOBI-Crane  Voyager

Table of contents

1.	Safety	4
2.	Technical data.....	6
2.1	Properties and performance.....	6
2.2	Overview	7
2.3	Build height BH.....	8
3.	Sub-assemblies	9
3.1	Cross units.....	9
3.2	Engine unit.....	12
3.3	Media connection.....	13
3.4	Pillar units.....	16
3.5	Suspensions	19
3.6	Tool adapters	22
4.	Control units	26
4.1	Overview of combinations	26
4.2	Control cable.....	28
4.3	Control units.....	28
5.	Accessories	30
5.1	Rotation brake	30
5.2	Encoder	31
5.3	Brackets for control units	32
6.	Circuit diagram and parameter settings.....	33
6.1	Circuit diagram Mechlift Pro	33
6.2	Circuit diagram control units.....	34
6.3	Circuit diagram limit switches	35
6.4	Electrical cabinet.....	36
6.5	Parameter settings 150/250 kg.....	38
7.	Installation and commissioning.....	40
7.1	Mechanical installation	40
7.2	Electrical installation	40
7.3	Setting of encoder (option)	41
8.	User instructions	42
9.	Service, maintenance & running.....	43
9.1	Recommended spare parts / wear parts	44
9.2	Service record — Mechlift Pro 150/250 electric.....	45
9.3	Chain and chain sprocket.....	47
9.4	Replacement of chain	48
9.5	Adjustment of spindle limit switch.....	49
9.6	Replacement of sliding blocks.....	50
9.7	Troubleshooting.....	51
9.8	Trip history and inverter status.....	52
10.	EC certificate	54
11.	Revisions	55

Although the greatest care was taken regarding the information in this catalogue, we assume no responsibility for any errors. We reserve the right to make changes.

The illustrations in the catalogue represent the described products, but the delivered goods may differ in some respects from the illustrations.

The right is reserved to make changes in design and dimensions compared with the information in the catalogue in order not to prevent development of designs, material and manufacturing methods.

The customer is reminded that in the purchase of Movomech's products for application on the job or elsewhere, there is supplementary, current information that could not be included in the catalogue in terms of recommendations on each product's suitability regarding different combinations of Movomech's comprehensive product line.

All relevant information must be provided to the persons who are responsible for the application of the product.

1. Safety

Movomech's equipment is manufactured in accordance with the latest technological advances, and according to the latest applicable European standards and directions. The aim of this documentation is to provide the user with practical instructions for safe operation and simple maintenance of the equipment.

Anyone who deals with the installation of the equipment (including related equipment), operational procedure, use, maintenance, and/or repair functions must have read and understood:

- the instruction manual,
- the safety regulations, and
- the safety instructions for each individual section.

In order to avoid misuse and to ensure the reliable operation of the products, we recommend that the instruction manual is always available to the user/operator.

Intended usage

The equipment is intended exclusively for transportation, lifting and lowering of load. Any other use, including the towing of a load and the transportation of passengers, is prohibited (see below for more examples). RonI does not accept responsibility for damage caused by such use. All risks are the sole responsibility of the user.

The equipment may only be used in perfect technical condition by trained staff, and in accordance with current safety and work protection regulations. Furthermore, the user must observe operational and maintenance conditions contained in the instruction manual. Severe personal injury and damage to equipment can be caused by:

- removal of covers and casings,
- non-professional installation of equipment,
- incorrect usage, or
- insufficient maintenance.

Prohibited usage

Certain types of activities and operations are prohibited, as in specific circumstances they can cause personal injury as well as permanent damage to the construction. For example:

- It is prohibited to convey passengers using the equipment.
- Never transport suspended loads above anyone's head.
- Never drop a suspended load, and make sure it is lifted in a straight line.
- Never loosen secured or fastened loads by using the equipment.
- Do not overload.
- Do not leave a suspended load unattended.

General safety aspects

The instruction manual should always be kept within easy reach of the equipment. It contains important safety information and sections that relate to guidelines, norms, and regulations. Failure to follow the safety regulations in this instruction manual may result in personal injury or death.

In addition to the instruction manual, generally applicable regulations and rules must be followed and adhered to in order to avoid accidents and protect the environment. This also applies to regulations relating to the handling of products dangerous to the environment and the use of personal safety equipment.

As regards all work associated directly or indirectly with the equipment, the user must follow and adhere to all the above regulations as well as current work protection and safety regulations. In spite of this, a life-threatening risk still prevails in cases where the equipment is used and operated by non-trained or non-instructed staff in a non-professional or non-intended way.

The user should supplement the instruction manual with instructions that consider the nature of the operation, e.g. company organisation, work procedures, and number of staff.

The members of staff who are assigned to work with the equipment must have read the instruction manual prior to undertaking any work, and he/she should pay particular attention to the chapters containing safety instructions. It is too late once work has commenced. This applies in particular to members of staff who are working with the equipment on a temporary basis, e.g. for maintenance purposes.

When convenient, the staff should be tested on their knowledge of the manual's contents that relate to safety and accident awareness.

The user is responsible for ensuring that the equipment is used only when it is in perfect condition and that all applicable and relevant safety regulations and requirements are followed.

The equipment should be taken out of operation immediately if functional damage or defects are discovered.

Personal safety equipment should be used as and when necessary, or when required by regulations.

Safety and warning devices, such as signs, stickers and labels must not be removed or made illegible.

All safety and warning devices on or adjacent to the equipment should be complete and maintained in a legible/functional condition.

All changes, extensions or reconstruction that may affect safety are forbidden without written permission from RonI. This also applies to assembly and adjustment of safety equipment and welding of structural parts.

Spare parts must comply with Movomech's stated technical requirements. This compliance is guaranteed when original spare parts are used. The intervals prescribed or stated in the instruction manual for regular testing/inspection must be adhered to!

Staff selection and qualifications

Reliable staff must carry out work with/on the equipment. Regulations that apply to under-age persons must be followed.

The user is responsible for supplying necessary training and instructions to those that he/she employs, including professionals and/or apprentices.

It is recommended that the user draws up instructions and guidelines relating to the causes of errors, communicates these to the relevant staff, and posts directions on appropriate and clearly visible places.

It is recommended that the user makes sure that the knowledge of the staff is adequate as regards the following points, prior to the operation of the construction:

- knowledge of the contents of the instruction manual,
- knowledge of the safety and user regulations contained therein,
- and knowledge of applicable work protection regulations.

Only trained and instructed staff should be permitted to work with the equipment. Parameters relating to use, maintenance, and installation should be clarified.

Safety instructions for usage

The only persons allowed to work on the electrical equipment are competent staff members who work in accordance with regulations and standards for high-voltage equipment.

No persons under the influence of drugs, alcohol or medication which affects their ability to react, are allowed to use, maintain, or repair the construction.

All stated actions and instructions relating to work protection and issues relating to general safety and protection of workers that should be carried out or studied prior to, during or following operation must be followed to the letter. Failure to do so may result in fatal accidents.

The equipment should be stopped or taken out of operation at the time of detection of faults relating to work protection and operational accessibility.

Safety equipment must not be deactivated, altered or used in a way that conflicts with applicable regulations.

Appropriate actions must be taken to ensure safe operation and functional conditions for the user.

The equipment should only be used when all protective and safety equipment, such as detachable guards and emergency stop devices, are in place and in working order.

Any type of modification and alteration of the equipment is prohibited. However, this does not apply to lesser changes that do not affect the strength, operational safety or work protection, or to actions which promote an increased level of safety.

The fundamental responsibility for these changes lies with the user. If in doubt, contact RonI for written approval of the actions prior to implementation.

The equipment should be stopped and locked immediately when functional faults occur. Faults should be corrected immediately!

Following an "emergency stop" the user has to wait for the cause of the disruption to be repaired and for an assurance that there is no further danger before he/she reconnects the equipment and resumes operation.

The equipment should be disconnected immediately in the following cases:

- when electrical equipment, cables and/or insulation material is damaged, or
- when work protection equipment is damaged.

Specific local circumstances or applications may lead to situations that were unknown at the time of writing this document. In such cases, the user must ensure safe operation and disconnect the equipment until measures to maintain safe operation have been carried out in conjunction with RonI or other authorised party.

Ensure that no one can become injured when they use the equipment prior to connecting/activating the equipment.

If the user notices the presence of persons who may become injured during operation, the operation should be discontinued immediately and must not be resumed until these persons have left the dangerous area.

The user must make sure that the equipment is in a perfect and operationally safe condition prior to all operations using the equipment.

The user should carry out all prescribed safety measures and make sure that automated procedures are completed when the equipment is disconnected (e.g. when there are deficiencies as regards operational and personal safety, an emergency situation exists, repair or maintenance is being carried out, damage is noticed or at the completion of work).

Work with the equipment is only allowed when the operator has been instructed to do so by his superior, and if the operator has knowledge of the equipment and its function.



2. Technical data

Flexible lifting unit

Electric Mechlif Pro is an ergonomically designed moment absorbing lifter which can be used for many lifting solutions. It can be fitted with standardised or customized grippers, and with accessories such as rotation units, brake unites, programmable stop positions, and more.

Several configurations

Electric Mechlif Pro is modular and can be supplied in many different configurations. It can also be integrated with Powerdrive drive units for driven sideways motions, or with Mechbelt linear unit for an automated "pick and place" type of handling.

Moment absorbing

Electric Mechlif Pro 150 and 250 consist of telescoping aluminium profiles that are anodized and thereby completely maintenance free. In the pillar unit there are torque-absorbing sliding blocks, which enable load outside the lifter's vertical lift shaft.

Many application areas

Typical application areas for electric Mechlif Pro are handling of cable rolls, mat rolls, tanks, doors, windows, and various types of automotive parts such as vehicle doors, sunroofs, seats, windshields, hoods, etc.

2.1 Properties and performance

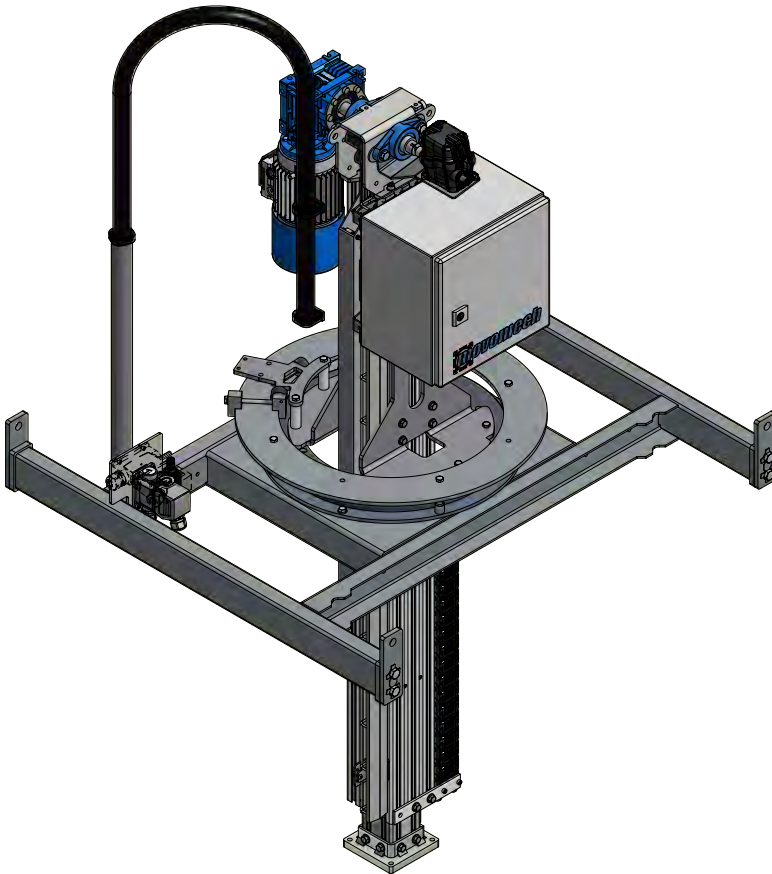

Technical data		Mechlif Pro 150 / 250
Max load	kg	150 / 250
Min load	kg	5 ¹
Max moment	Nm	800
Tare weight	kg	112-203 ²
Stroke SL	mm	500-1500
Length L	mm	SL+805/980/1045 ³
Rotation	°	0-310/360 ⁴
Lifting speed	m/min	0-10
Inner profile	-	MP120C
Outer profile	-	MP160
Roller chain	" (mm)	1/2 (12,7)
Width c/c	mm	800, 1000
Height PH	mm	50-490

¹ To overcome the frictional force of the sliding blocks

² Depends on configuration

³ Depends on media connection, tool adapter not included

⁴ Depends on media connection

Media & Environment		Mechlif Pro 150 / 250
Motor output	kW	0,25
Voltage	V	1x230, N, PE (±15) 50/60 Hz
Fuse	AT	10
Enclosure class	IP	54
Work temperature	°C	5-40 (indoor use)
Noise level	dB (A)	<70

2.2 Overview

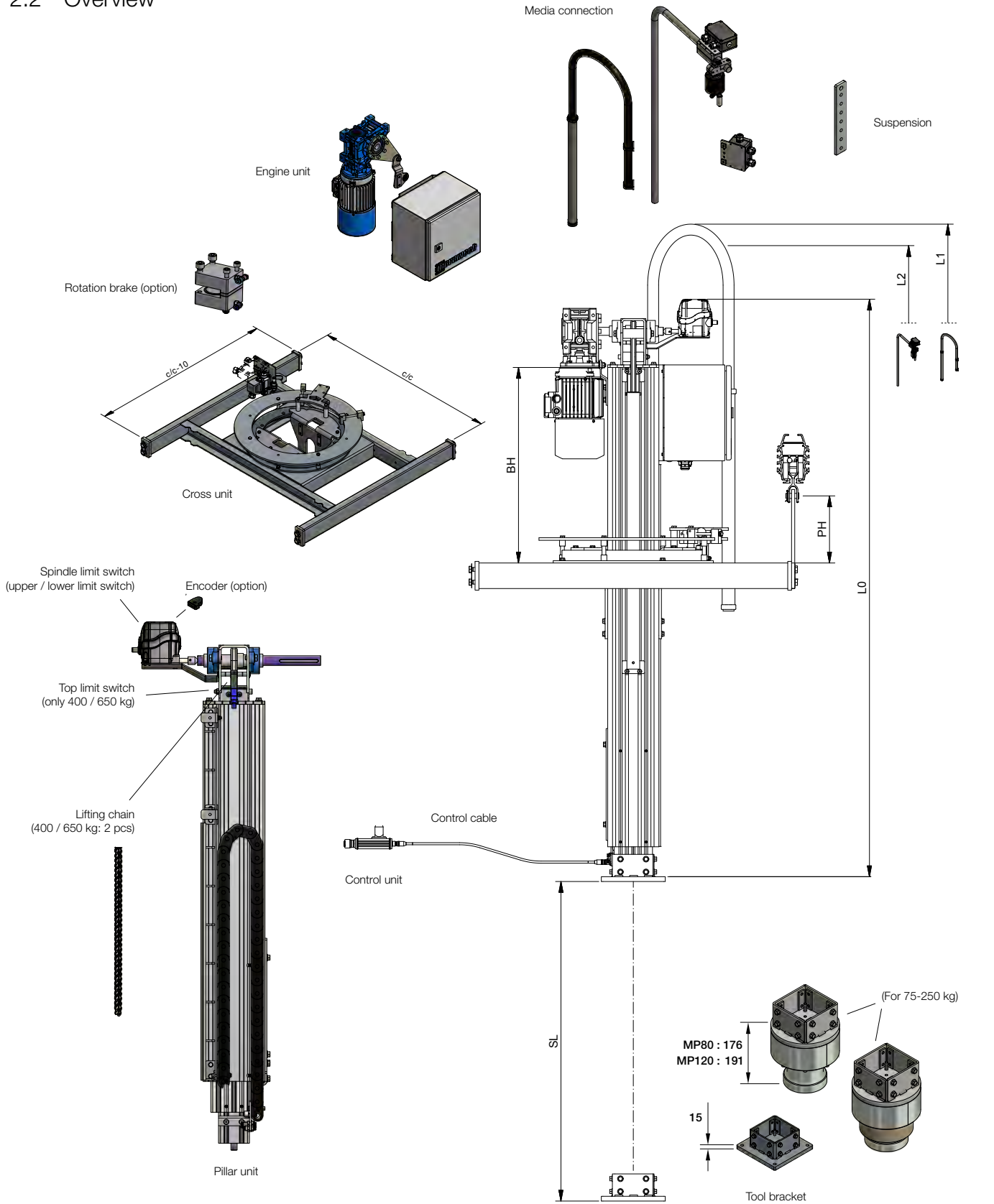

- General overview for all versions:
75/150/250/400/650 kg

⁰ Profile cross unit includes media connection
¹ Media connection standard
² Media connection with free rotation

Pillar unit		742716	742717	742718	742719	742720	742721
Stroke SL	mm	500	750	1000	1250	1500	500-1500
Length L ⁰	mm	1305	1555	1805	2055	2305	SL+805
Length L ¹	mm	1545	1795	2045	2295	2545	SL+1045
Length L ²	mm	1480	1730	1980	2230	2480	SL+980

2.3 Build height BH

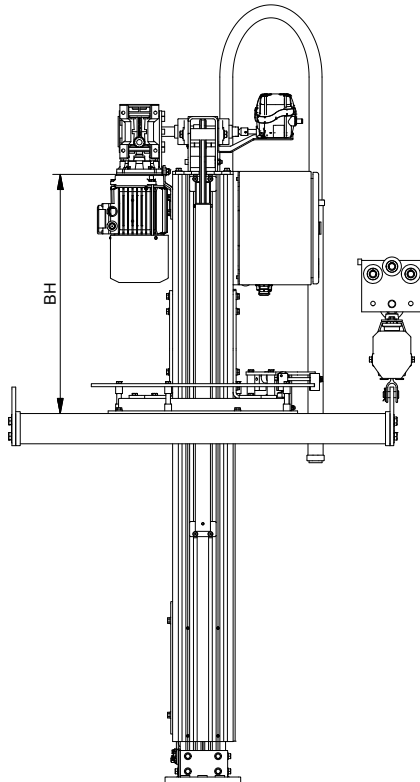

- Note that the build height BH is indicated from the upper profile end to the top edge of the cross unit, regardless of version.

Cross unit	c/c 800	c/c 1000
Profile unit	742747	742748
Steel unit, up	742705	742707
Steel unit, down	742704	742706

Build height BH	SL	500	750	1000	1250	1500
Profile unit	mm	460 - 930 (695*)	460 - 1180 (820*)	460 - 1430 (945*)	460 - 1680 (1070*)	460 - 1930 (1195*)
Steel unit, up	mm	630 - 1045 (835*)	630 - 1295 (960*)	630 - 1545 (1085*)	630 - 1795 (1210*)	630 - 2045 (1335*)
Steel unit, down	mm	450 - 770 (610*)	450 - 1020 (735*)	450 - 1270 (860*)	450 - 1520 (985*)	450 - 1770 (1110*)

* BH unless otherwise specified when ordering.

3. Sub-assemblies

3.1 Cross units

742747/-8 Cross unit profile MP120

#	Article nr.	Designation	Quantity
1	*1	Profile MP80, L=L1 mm	2
2	*2	Profile MP80, L=L2 mm	2
3	742787	Electrical connection	1
4	731306	Gable suspension for MP80	4
5	730182	Mounting angle MVL80	4
6	730167	End cover MA80	4
7	730165	Mounting angle MVL160	4
8	730216	Screw M6SZ M8x12	66
9	731379	MM2x8 t-slot nut double c/c 120	8
10	740500	MM2x8 t-slot nut double c/c 40	24
11	730115	MM8 t-slot nut single	2

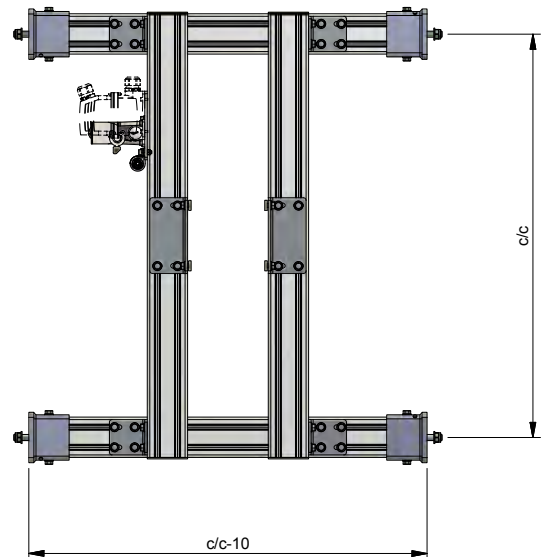
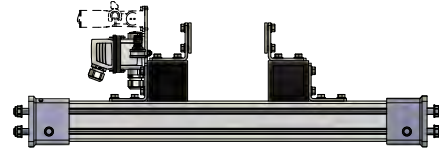
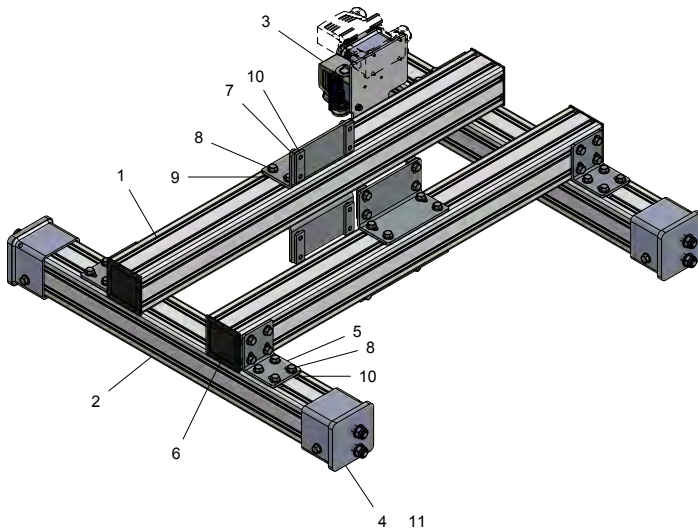

Cross unit	742747	742748
c/c mm	800	1000
Article nr. *1	730104	731376
Length L1 mm	770	970
Article nr. *2	731377	731378
Length L2 mm	880	1080
Weight kg	27	30

742705/-7 Cross unit, bracket up

#	Article nr.	Designation	Quantity
1	*1	Cross unit, steel	1
2	741895	Swivel ring	1
3	742756	Bracket for slewing ring	2
4	741896	Adapter ring	6
5	731316	Clamp 45x25x20 M8	2
6	731317	Clamp 45x25x20 D=8.5	2
7	742750	Brake disc	1
8	742787	Electrical connection	1
9	741899	Distance sleeve 18/9	4
10	742753	Bracket for brake caliper	1
11	730449	Rubber damper	2
12	736083	Screw M6SZ M8x30	4
13	736170	Securing plate	4
14	740500	MM2x8 t-slot nut double c/c 40	8
15	740980	Pipe bracket	1
16	741071	Nut M6MF M8 Nyloc	14
17	730297	Screw M6SZ M8x40	2
18	730218	Screw M6SZ M8x16	16
19	730308	Washer BRB 8.4x16x1.5	2
20	731322	Screw M6S M8x90, half thread	2
21	731323	Screw M6S M8x100, half thread	6
22	731347	Screw M6S M12x25, full thread	8
23	731684	Screw M6S M8x35, full thread	4
24	742751	Distance sleeve 20/8.5x54	2

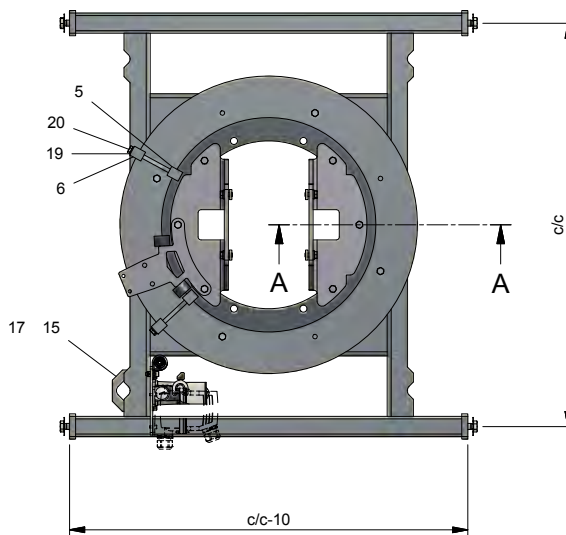
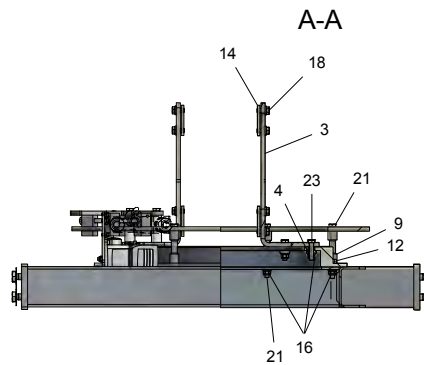
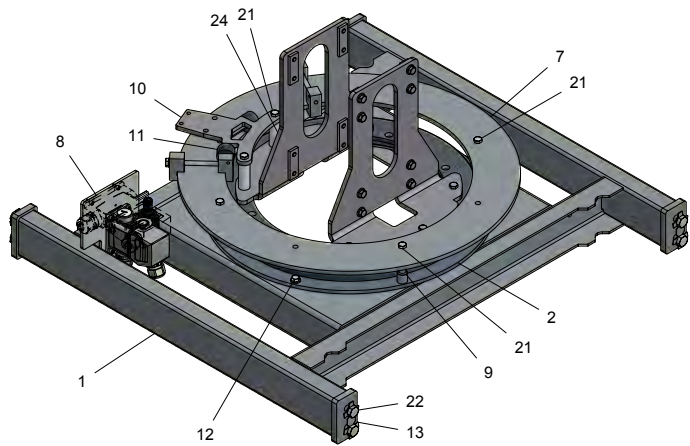

Cross unit		742705	742707
c/c	mm	800	1000
Article nr.	*1	731345	731346
Weight	kg	61	66

742704/-6 Cross unit, bracket down

#	Article nr.	Designation	Quantity
1	*1	Cross unit, steel	1
2	741895	Swivel ring	1
3	742756	Bracket for slewing ring	2
4	741896	Adapter ring	6
5	731316	Clamp 45x25x20 M8	2
6	731317	Clamp 45x25x20 D=8.5	2
7	742750	Brake disc	1
8	742787	Electrical connection	1
9	741899	Distance sleeve 18/9	4
10	742753	Bracket for brake caliper	1
11	730449	Rubber damper	2
12	736083	Screw M6SZ M8x30	4
13	736170	Securing plate	4
14	740500	MM2x8 t-slot nut double c/c 40	8
15	740980	Pipe bracket	1
16	741071	Nut M6MF M8 Nyloc	14
17	730297	Screw M6SZ M8x40	2
18	730218	Screw M6SZ M8x16	16
19	730308	Washer BRB 8.4x16x1.5	2
20	731322	Screw M6S M8x90, half thread	2
21	731323	Screw M6S M8x100, half thread	6
22	731347	Screw M6S M12x25, full thread	8
23	731684	Screw M6S M8x35, full thread	4
24	742751	Distance sleeve 20/8.5x54	2

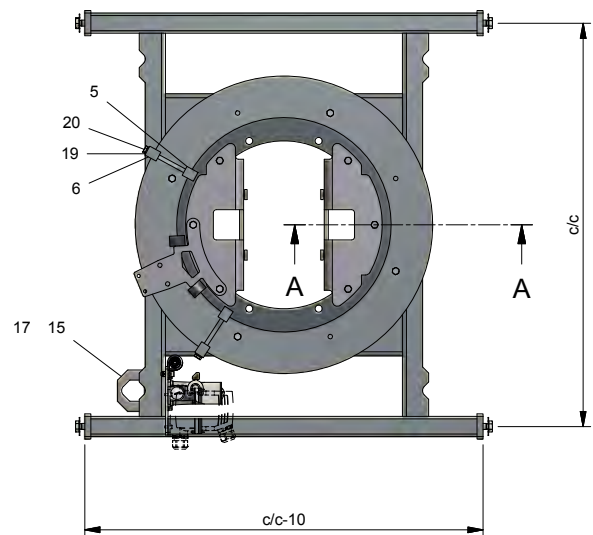
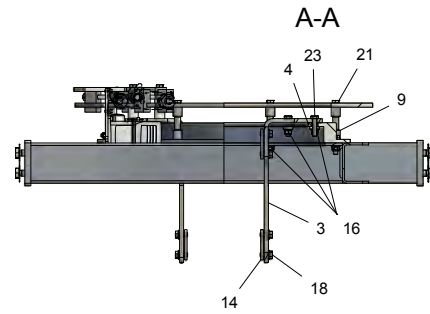
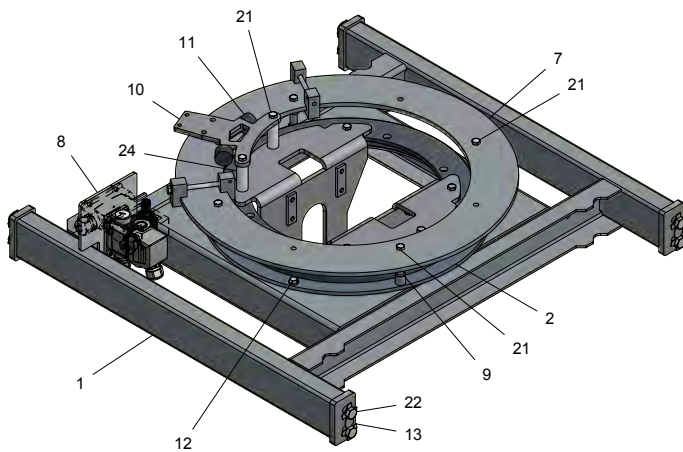

Cross unit		742704	742706
c/c	mm	800	1000
Article nr.	*1	731345	731346
Weight	kg	61	66

3.2 Engine unit

742741/-2 Engine unit				
#	Article nr.	Designation	Quantity	
1	742175	Worm gear motor 0.75 kW	R	1
2	742808	Electric cabinet 75-250 kg		1
3	740430	Bracket for cabinet		1
4	730216	Screw M6SZ M8x12		6
5	730215	Screw M6SZ M8x10		4
6	730115	MM8 t-slot nut single		4
7	731231	Cable fitting M20 EMC		1
8	730889	Terminal strip 2.5		1
9	735540	Nut M6MF M10		1
10	740500	MM2x8 t-slot nut double c/c 40		1
11	732130	Washer SRKB 11x35x2		1
12	731326	Screw M6S M10x35, full thread		1
13	742811	Cable entry Ø18/25-8		1
14	742812	Torque stay 75-250 kg		1

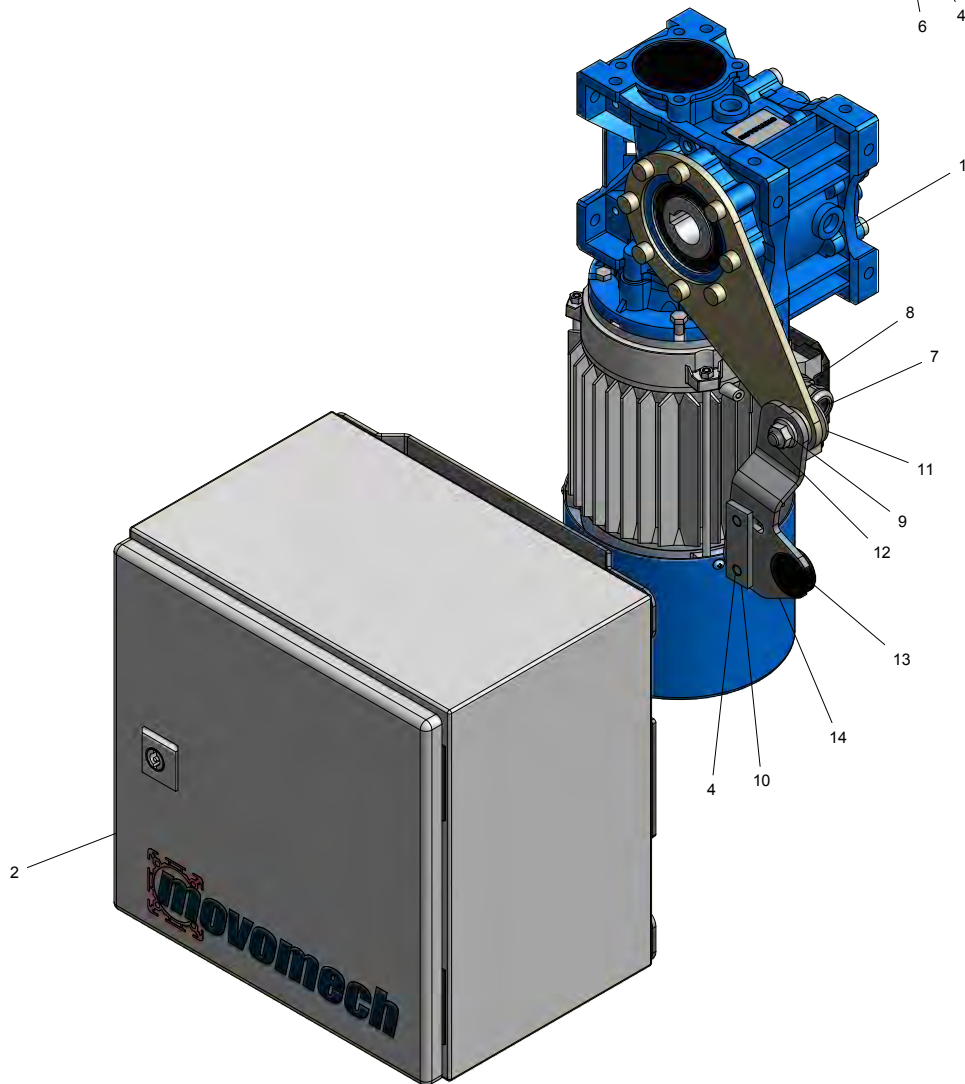
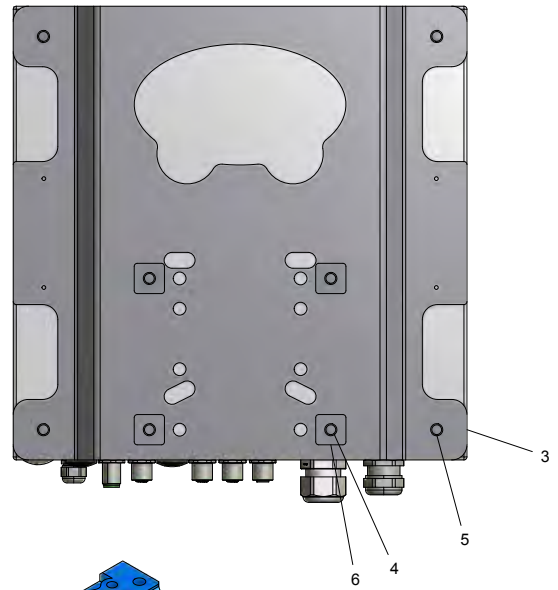

Engine unit	742741	742742
Load kg	150	250
Weight kg	43	43

R: spare part S: wear part

3.3 Media connection

742736		Standard connection, 0-310°	
#	Article nr.	Designation	Quantity
1	734069	Cable protection hose L=L1	1
2	737313	Pipe 40x2 L=L2	1
3	734046	Hose clamp	2
4	734046M	Hose clamp	4

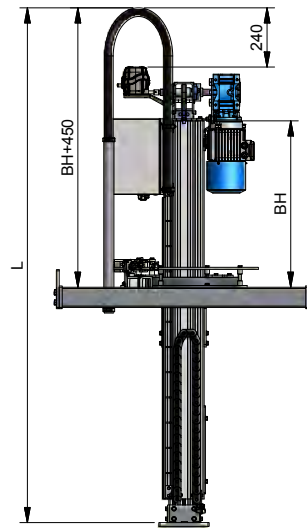
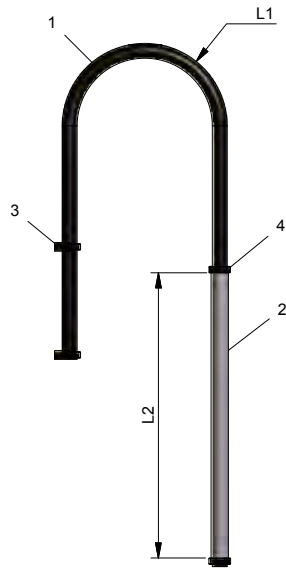

Connection		742736
Length L1	mm	BH+1500
Length L2	mm	BH
Weight	kg	1,4

742737		Connection, 360° free rotation, 6 pol + 12 pol	
#	Article nr.	Designation	Quantity
1	742123	Slip ring 6 pol + 12 pol	1
2	742178	Conduit pipe	1
3	742794	Sleeve	2
4	742813	Connection box	2
5	742179	Shaft adapter	1
6	730528	Screw MC6S M4x10	8
7	730727	Screw MC6S M8x25	3
8	730759	Screw MC6S M6x40	4
9	730965	Clamp D=27 L=120 two-part	1
10	730968	Clamp D=27 90° two-part	1
11	731719	Screw MC6S M8x55	2
12	739284	Push-in L-fitting 3/8"-8	1
13	730115	MM8 t-slot nut single	2
14	742177	Attachment plate	2
15	730117	Locking nut M8	2
16	730216	Screw M6SZ M8x12	2
17	742771	Push-in L-fitting, rotatable 3/8"-8	1
18	730304	Screw MF6S M8x25	2
19	730308	Washer BRB 8.4x16x1.5	2

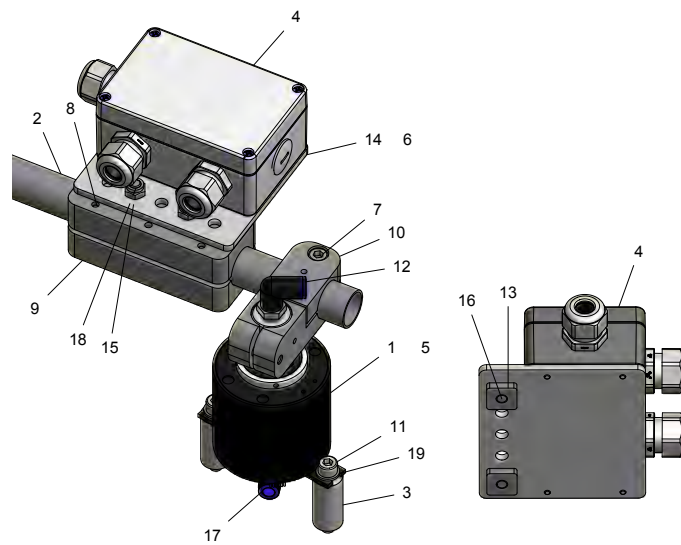
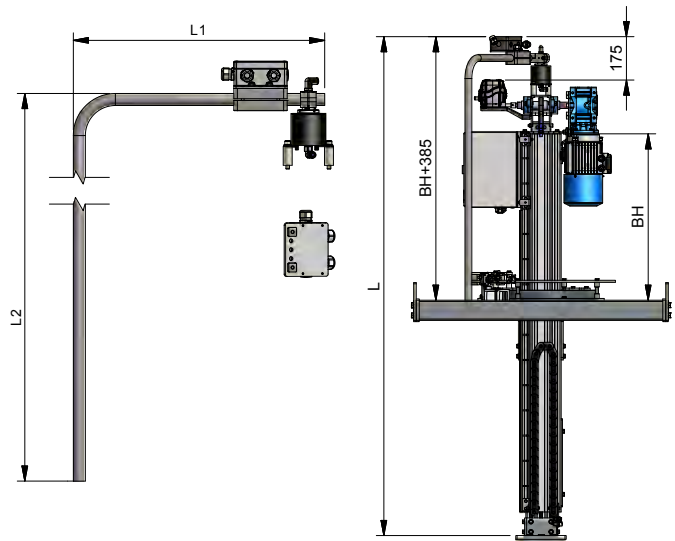

742738 Connection, 360° free rotation, 6 pol

#	Article nr.	Designation	Quantity
1	742122	Slip ring 6 pol	1
2	742178	Conduit pipe	1
3	742794	Sleeve	2
4	742813	Connection box	2
5	742179	Shaft adapter	1
6	730528	Screw MC6S M4x10	8
7	730727	Screw MC6S M8x25	3
8	730759	Screw MC6S M6x40	4
9	730965	Clamp D=27 L=120 two-part	1
10	730968	Clamp D=27 90° two-part	1
11	731659	Retaining ring Ø25	1
12	731719	Screw MC6S M8x55	2
13	739284	Push-in L-fitting 3/8"-8	1
15	742177	Attachment plate	2
16	730115	MM8 t-slot nut single	2
17	730117	Locking nut M8	2
18	742771	Push-in L-fitting, rotatable 3/8"-8	1
19	730216	Screw M6SZ M8x12	2
20	730304	Screw MF6S M8x25	2
21	730308	Washer BRB 8.4x16x1.5	2

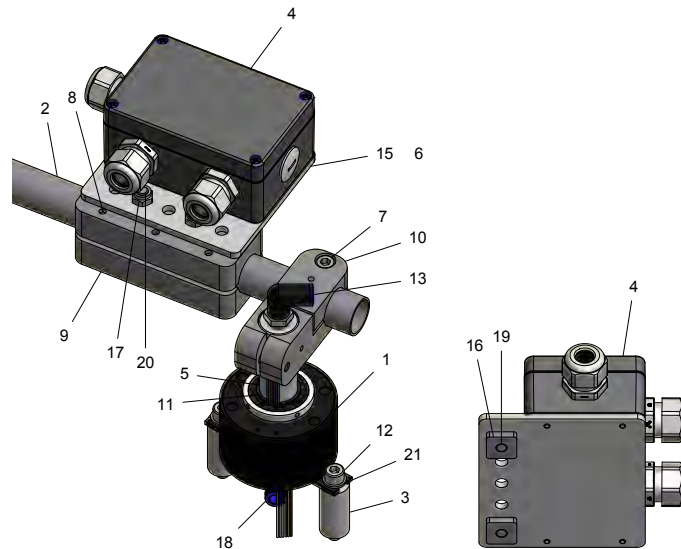
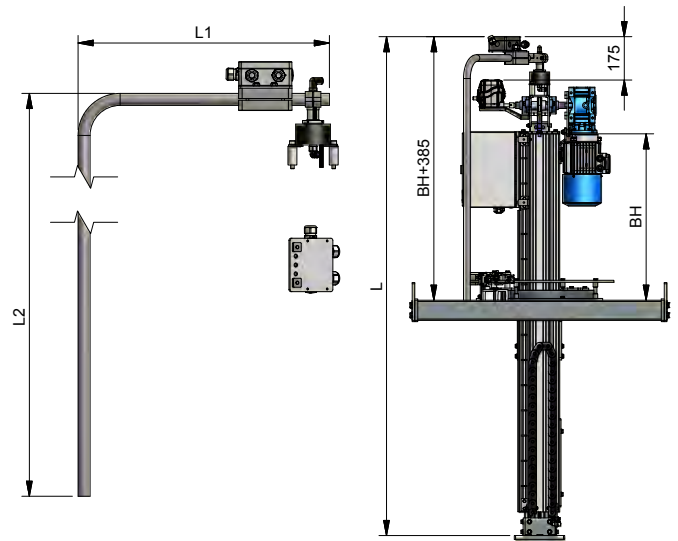

Connection		742737	742738
Length L1 c/c 800	mm	485	485
Length L1 c/c 1000	mm	565	565
Length L2	mm	BH+410	BH+410
Weight	kg	7,3	6,5

3.4 Pillar units

7427xx		Pillar unit 150/250 kg	
#	Article nr.	Designation	Quantity
1	*1	Outer profile MP160, L=L1	1
2	*2	Inner profile MP120, L=L2	1
3	731180	Top guiding MP120-MP160	1
4	730218	Screw M6SZ M8x16	2
5	730268	Washer BRB 6,4x12x1.5	6
6	730308	Washer BRB 8,4x16x1.5	4
7	730728	MM2x6 t-slot nut double c/c 30	3
8	730735	Sliding block MK40 L=30	S 16
9	730738	Wood screw countersunk spax 3.5x16	16
10	730879	Screw MC6S M5x40	2
11	735597	Screw MC6S M4x45	1
12	730115	MM8 t-slot nut single	2
13	730130	MM6 t-slot nut single	4
14	730216	Screw M6SZ M8x12	2
15	742210	Panel feed-through M12 8 pol	1
16	731253	Counterweight 1.5 kg	1
17	742760	Housing assembly 150/250 kg	1
18	731286	Support plate	1
19	731330	Screw MC6S M5x45	2
20	731331	Screw MC6S M6x10	1
21	731333	Screw MC6S M8x30	4
22	731336	Screw MF6S M6x10	1
23	731365	Locking nut M4	1
24	732106	Screw M6SF M8x30	4
25	731263	Cush drive M16x1.5 Simplex 1/2"	1
26	734665	Screw M6S M6x12, full thread	6
27	735576	Nut M6MF M5	4
28	742785	Chain guard bracket	2
29	739270	Push-in connector 4-4	1
30	739272	Push-in connector 8-8	1
31	739369	Screw K6S M5x20 A2 stainless	2
32	741069	Nut M6MF M5 Nyloc	2
33	741679	Cable, M12, 8 conductors, 5 m	1
34	741830	Lid, cable tray 50	L3
35	741832	Mesh cable tray 35x50	L4
36	742803	Bracket	2
37	742249	Screw MF6S M6x14	4
38	742790	Bracket	1
39	742791	Washer for cable tray	2
40	742788	Bracket	1
41	*3	Chain guard 40x60, L=L5	1
42	731261	Roller chain Simplex 1/2", L=L6	S 1
43	733239	Cable chain 10.0.40	R L7

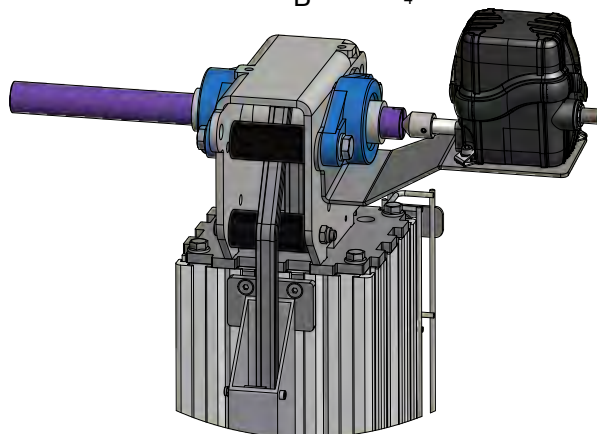
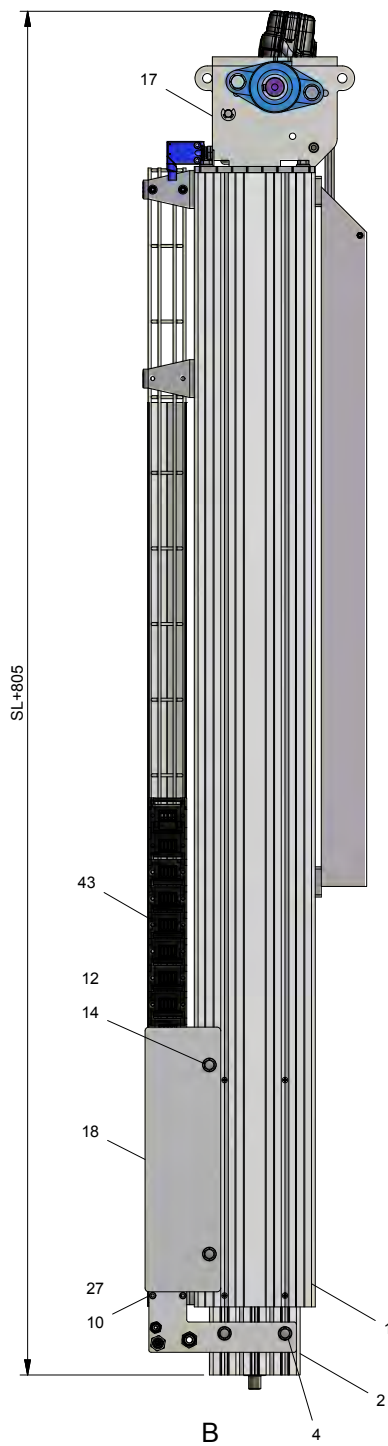

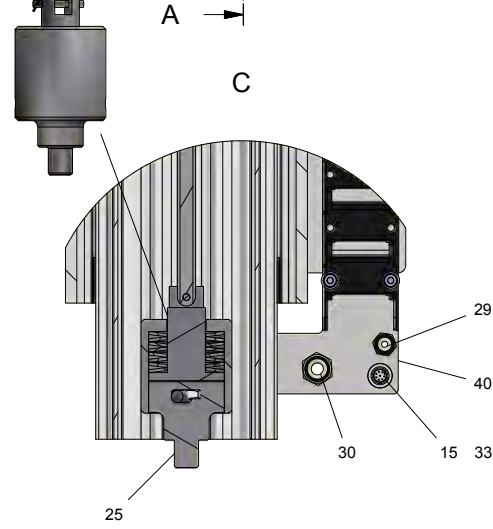
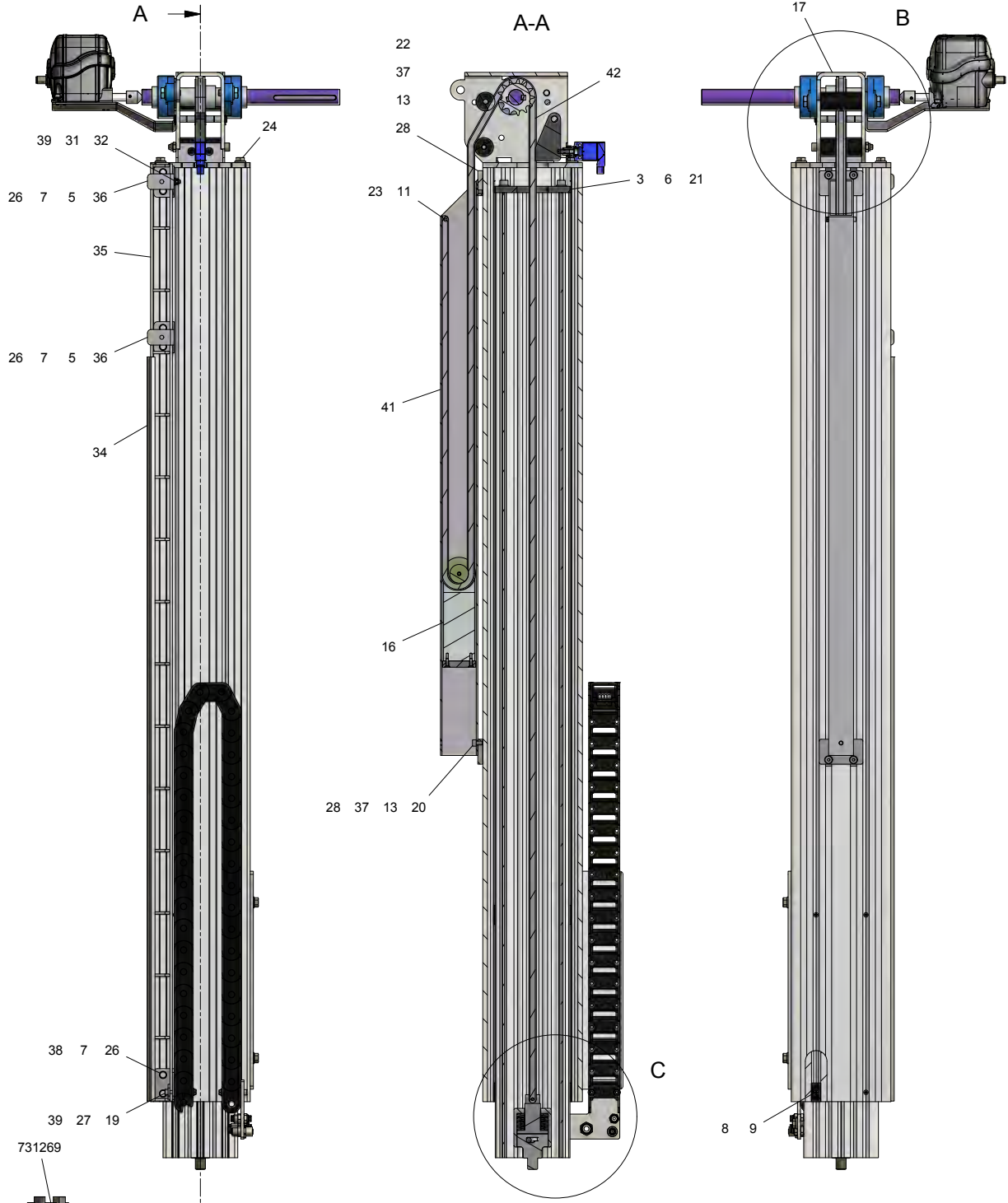

Pillar unit	742716	742717	742718	742719	742720	742721
Stroke SL mm	500	750	1000	1250	1500	500-1500
Article nr. *1	731183	731184	731185	731186	731187	731188
Length L1 mm	1000	1250	1500	1750	2000	SL+500
Article nr. *2	731218	731219	731220	731221	731222	731223
Length L2 mm	1050	1300	1550	1800	2050	SL+550
Length L3 mm	695	945	1200	1445	1695	SL+200
Length L4 mm	1005	1255	1505	1755	2005	SL+505
Article nr. *3	731238	731239	731240	731241	731242	731243
Length L5 mm	675	800	925	1050	1175	0,5xSL+425
Length L6 mm	2120	2620	3120	3620	1175	2xSL+1120
Length L7 mm	875	1085	1365	1575	4120	SL+365
Weight kg	40	46	53	60	66	0,028SL+26

R: spare part S: wear part

742760		Housing assembly 150/250 kg	
#	Article nr.	Designation	Quantity
1	742763	Housing, 150/250 kg	1
2	742782	Chain sprocket Simplex 1/2"	S 1
3	742211	Slack chain switch	R 1
4	742255	Rotary limit switch	R 1
5	742757	Flange bearing unit Ø25	2
6	731325	Screw M6S M10x25, full thread	2
7	732058	Screw MC6S M5x12	2
8	733598	Spring pin 4x18	1
9	734124	Reduction M20-M16	1
10	735508	Screw MC6S M8x90	1
11	740827	Flange plug M12 4 pol male	1
12	741586	Cable, M12, 8 conductors, 1 m	1
13	741681	Cable, M12, 4 conductors, 1 m	1
14	742202	Shaft adapter	1
15	742783	Flat key	1
16	730117	Locking nut M8	1
17	730307	Washer BRB 5,3x10x1	2
18	730549	Washer BRB 10,5x22x2	4
19	742768	Slide block	S 1
20	742769	Slide block shaft	1
21	742770	E Clip 9, stainless	4
22	742772	Bracket	1
23	742774	Drive shaft D=25	1
24	742776	Flat key 8x7-28	1
25	742777	Chain sleeve	2
26	742778	Distance sleeve	1
27	742779	Distance sleeve	1
28	730903	Screw M6S M10x30, full thread	2
29	731127	Spring pin 3x18	1

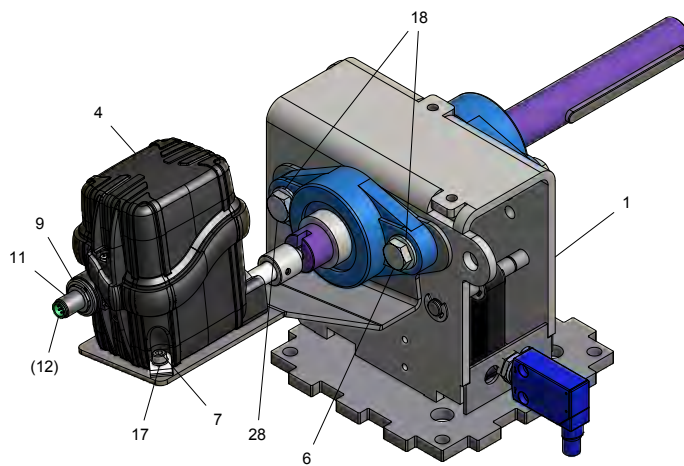

A-A

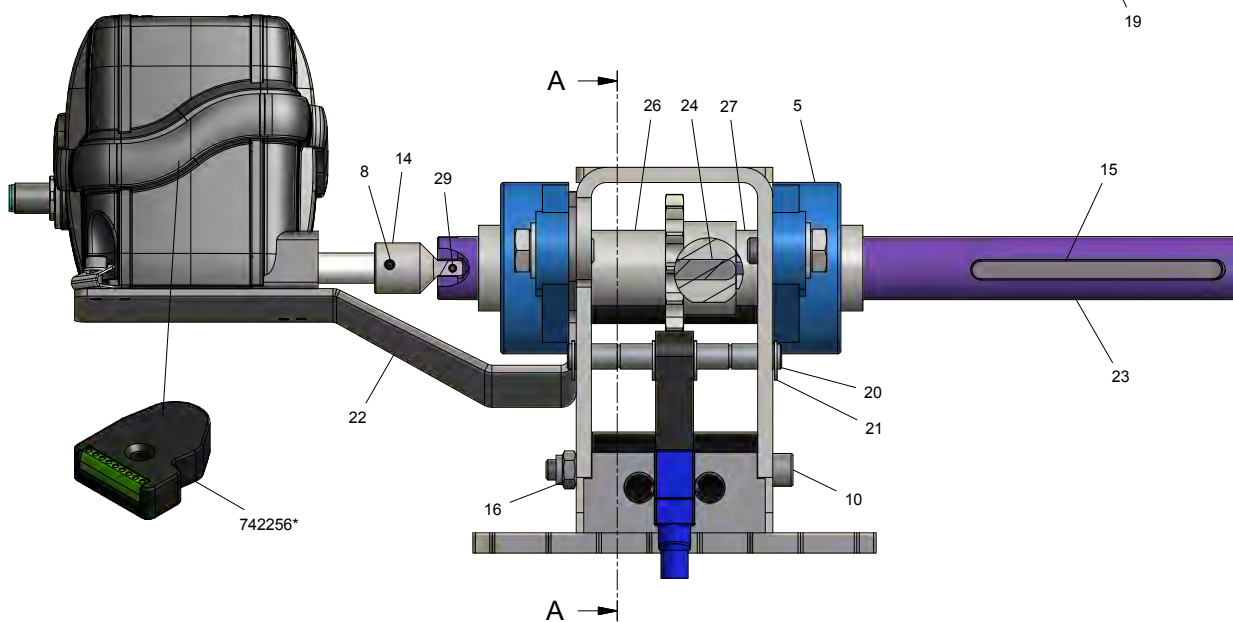
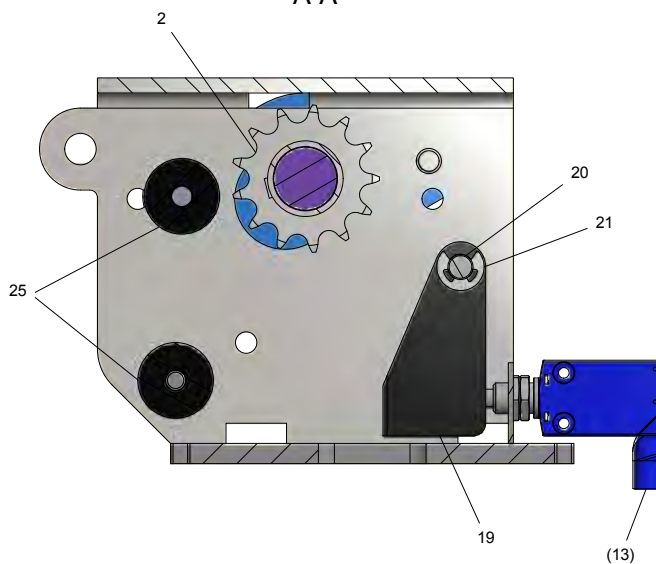

* Option, see page 31.

R: spare part S: wear part

3.5 Suspensions

73383x Pendulum PH 50

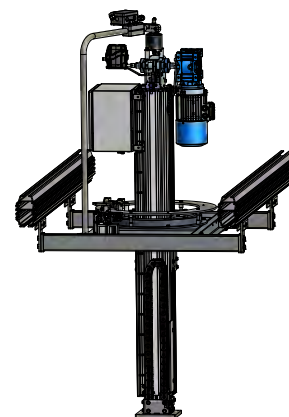
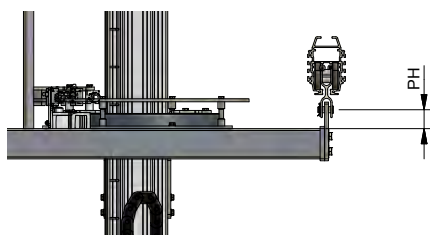
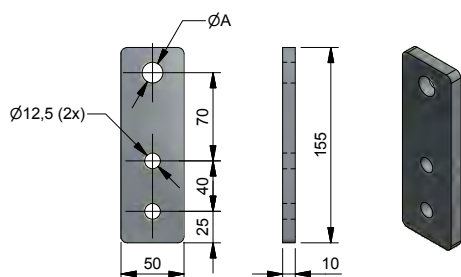

Suspension	733835	733837
ØA mm	16,5	20,5
Fits trolley	AHB1.1-2	AHB3
Weight/pc kg	0,6	0,6

74xxxx Suspension PH 90-210

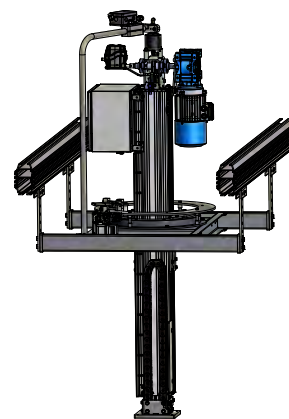
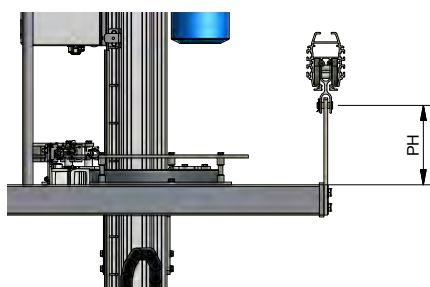
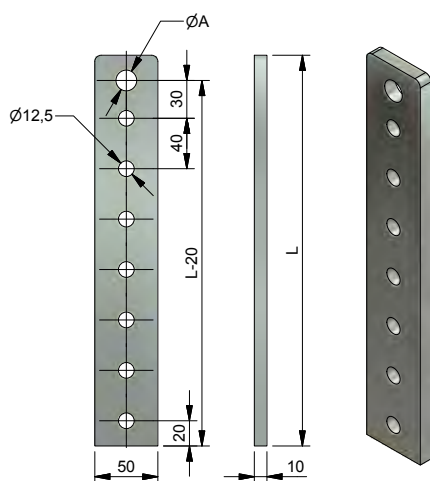

Suspension	740940	740941
ØA mm	16,5	20,5
Fits trolley	AHB1.1-2	AHB3
Weight/pc uncut kg	1,1	1,1

74xxxx		Pendulum 4x PH 250-370	
#	Article nr.	Designation	Quantity
1	*1	Pendulum 90-490 D=ØA L=L1	4
2	*2	Cross brace c/c=L2	4
3	*3	Threaded bar M12 L=L3	2
4	730255	Screw M6S M12x30, full thread	8
5	730726	Nut M6M M12	18
6	730244	Washer BRB 13x24x2	18
7	730484	Screw M6S M12x20, full thread	2
8	732267	Cable protection hose L=L3	2

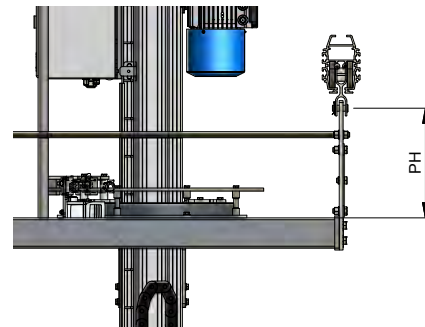
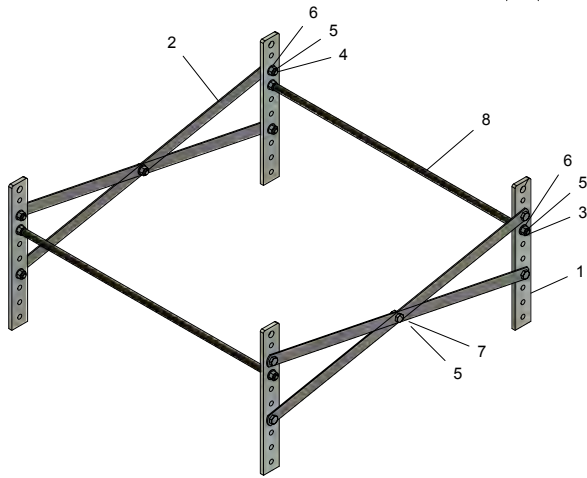
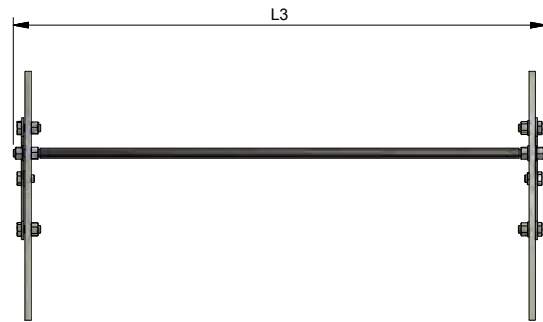
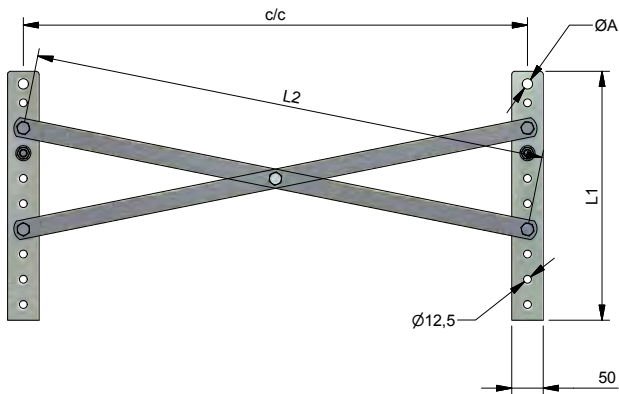
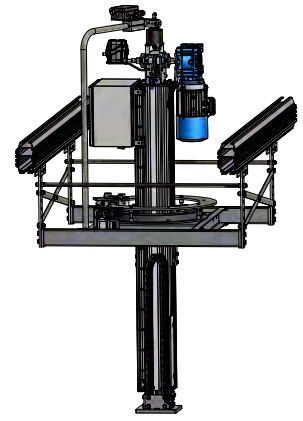

Suspension		740942	740943	740944	740945
c/c	mm	800	1000	800	1000
ØA	mm	16,5	16,5	20,5	20,5
Fits trolley		AHB1.1-2	AHB1.1-2	AHB3	AHB3
Article nr.	*1	740938	740938	740939	740939
Article nr.	*2	740950	740951	740950	740951
Length L2	mm	816	1013	816	1013
Article nr.	*3	740954	740955	740954	740955
Length L3	mm	845	1045	845	1045
Weight uncut	kg	10	11	10	11

Height PH		250	290	330	370
Length L1	mm	355	395	435	475

74xxxx		Pendulum 4x PH 410-490	
#	Article nr.	Designation	Quantity
1	*1	Pendulum 90-490 D=ØA L=L1	4
2	*2	Cross brace c/c=L2	4
3	*3	Threaded bar M12 L=L3	2
4	730255	Screw M6S M12x30, full thread	8
5	730726	Nut M6M M12	18
6	730244	Washer BRB 13x24x2	18
7	730484	Screw M6S M12x20, full thread	2
8	732267	Cable protection hose L=L3	2

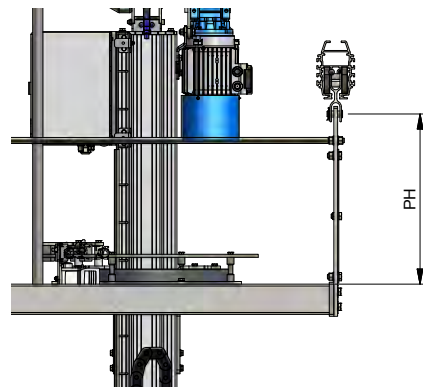
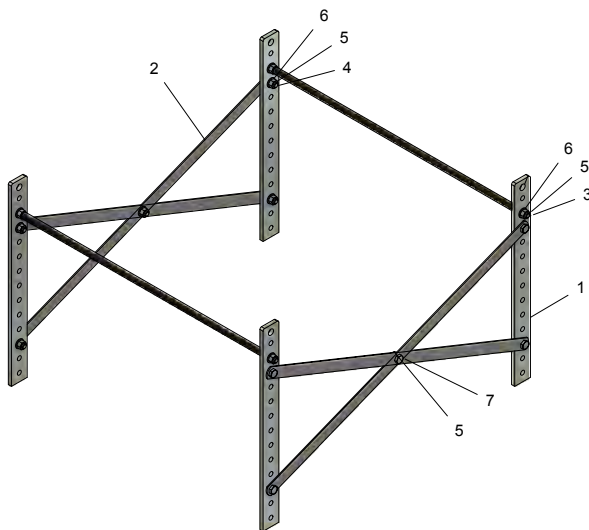
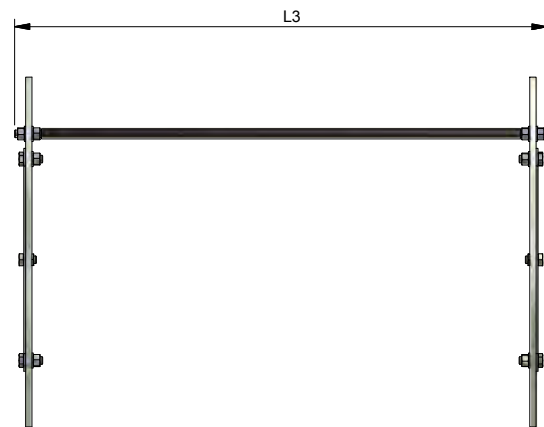
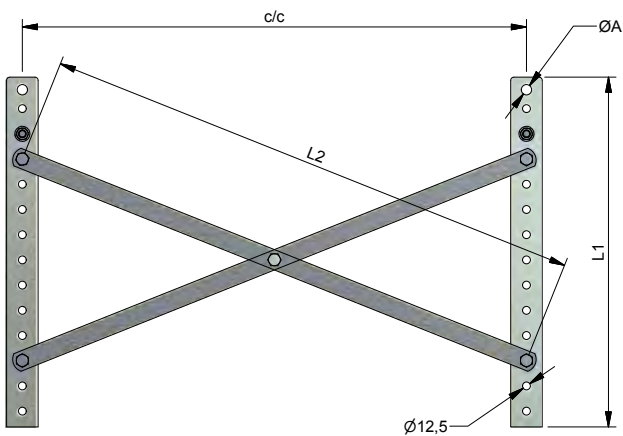
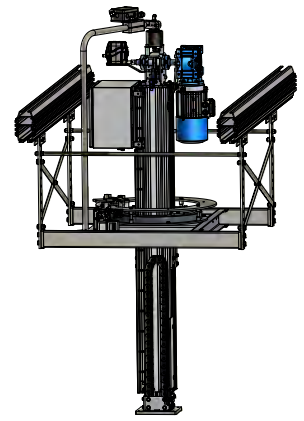

Suspension		740946	740947	740948	740949
c/c	mm	800	1000	800	1000
ØA	mm	16,5	16,5	20,5	20,5
Fits trolley		AHB1.1-2	AHB1.1-2	AHB3	AHB3
Article nr.	*1	740938	740938	740939	740939
Article nr.	*2	740950	740951	740950	740951
Length L2	mm	861,5	1050	861,5	1050
Article nr.	*3	740954	740955	740954	740955
Length L3	mm	845	1045	845	1045
Weight uncut		12	13	12	13

Height PH		410	450	490
Length L1	mm	515	555	595

3.6 Tool adapters

731501 Tool adapter MP120			
#	Article nr.	Designation	Quantity
1	731499	Bracket MP120	1
2	731333	Screw MC6S M8x30	4
3	740500	MM2x8 t-slot nut double c/c 40	8
4	730216	Screw M6SZ M8x12	16

A-A

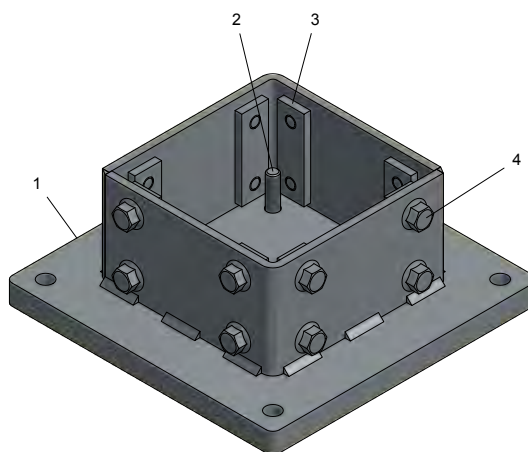
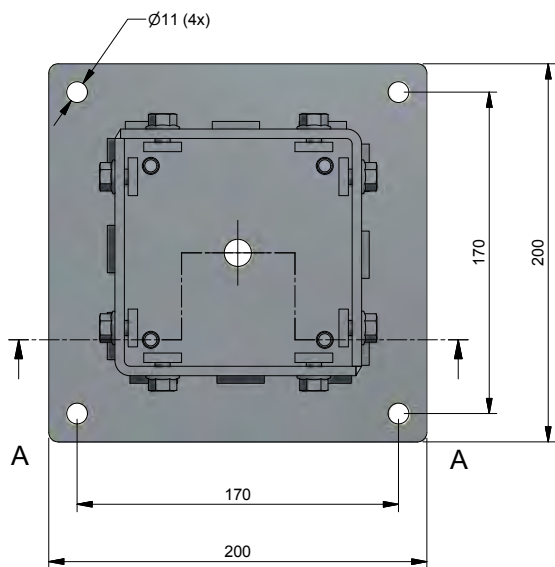
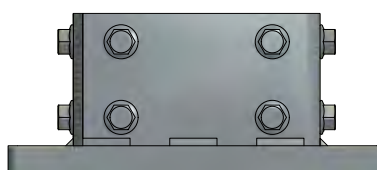
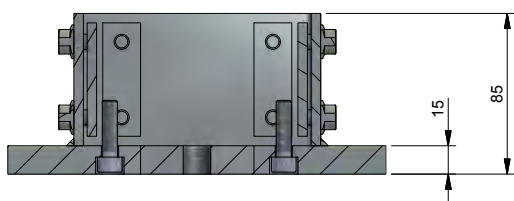

Tool adapter	731501
Weight kg	6,0

R: spare part S: wear part

739852 Rotation unit MP120

#	Article nr.	Designation	Quantity
1	739848	Bracket MP120, complete	1
2	739857	Shaft bearing assembly	1
3	732253	Cover, part 1/2	1
4	732254	Cover, part 2/2	1
5	739856	Shaft	1
6	739073	Rotation limiter (2 parts)	2
7	730280	Screw MC6S M6x20	4
8	731486	Screw MC6S M6x8	8
9	731493	Protection cap	1
10	731492	Damper	S
11	741744	Stud bolt M8x25	4
12	730117	Locking nut M8	4

- Provides an adjustable rotation of 0-320°.

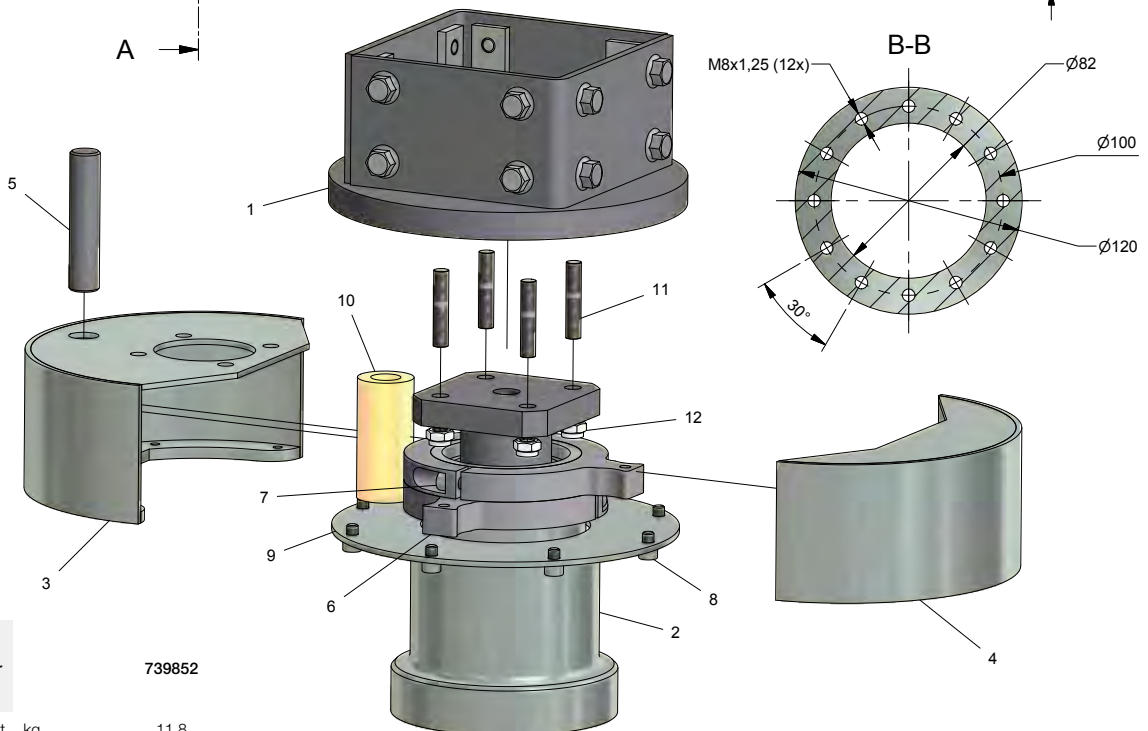
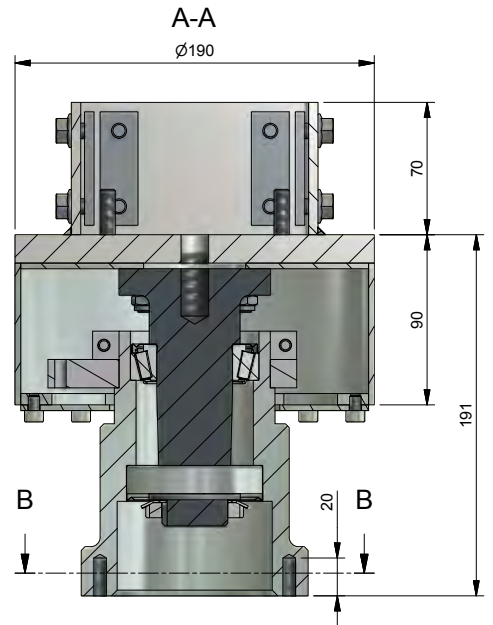
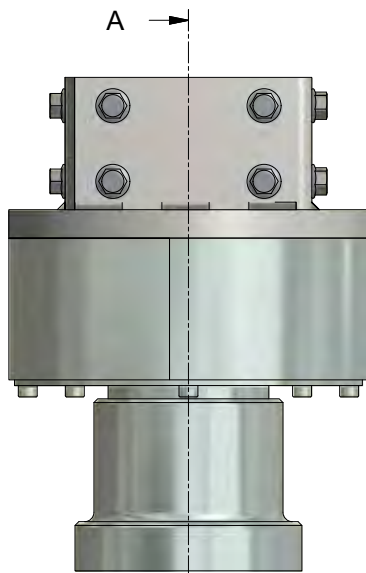
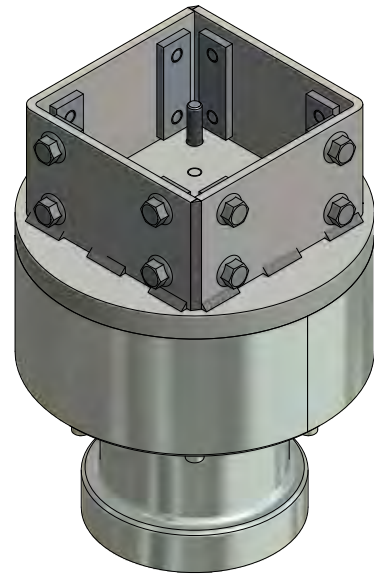

Tool adapter

739852

Weight kg 11,8

739853		Rotation unit MP120 with brake	
#	Article nr.	Designation	Quantity
1	739848	Bracket MP120, complete	1
2	732253	Cover, part 1/2	1
3	732254	Cover, part 2/2	1
4	739857	Shaft bearing assembly	1
5	731494	Brake unit	1
6	739856	Shaft	1
7	739073	Rotation limiter (2 parts)	2
8	730280	Screw MC6S M6x20	4
9	731486	Screw MC6S M6x8	8
10	731492	Damper	S 1
11	741744	Stud bolt M8x25	4
12	730117	Locking nut M8	4

- Provides an adjustable rotation of 0-320°.

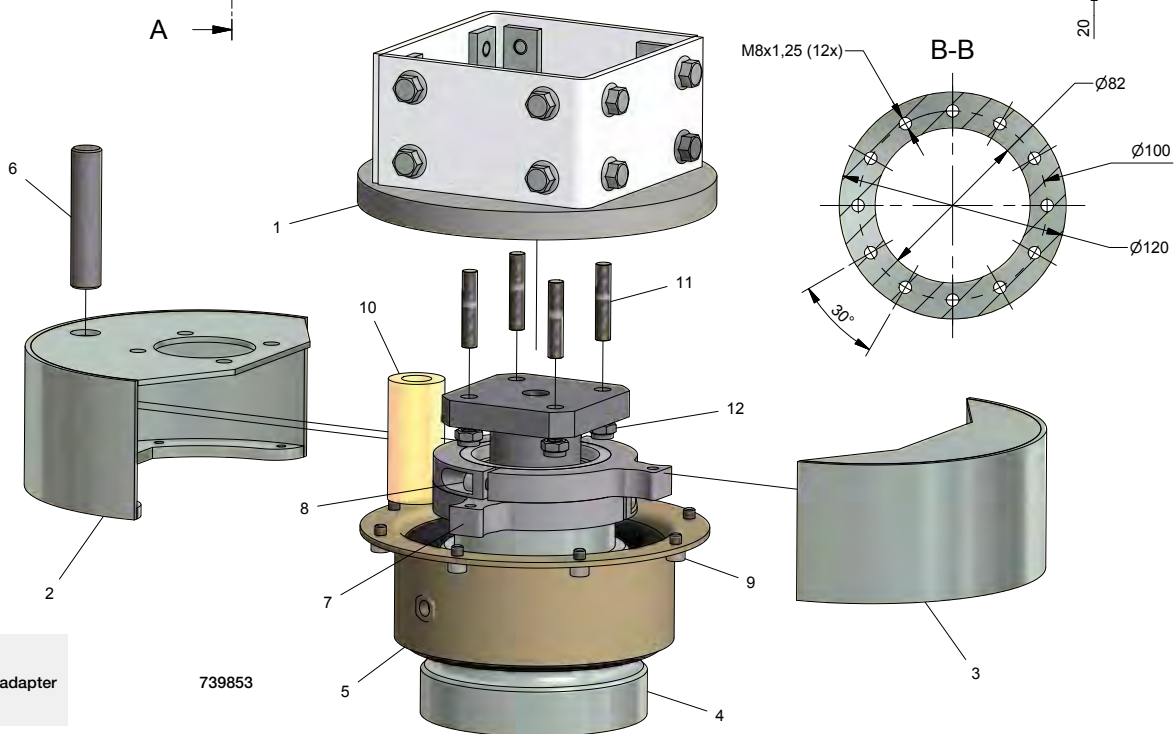
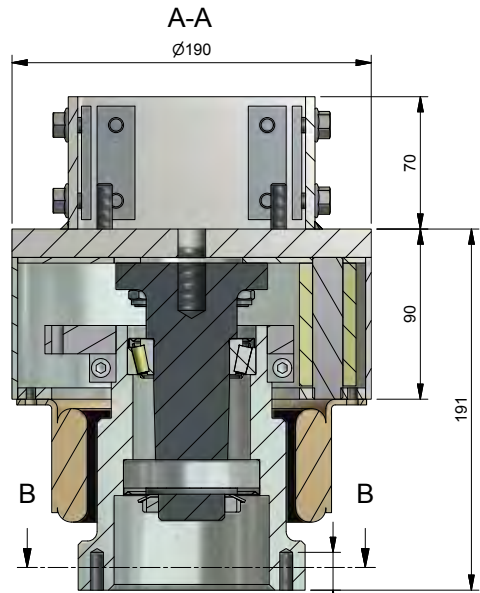
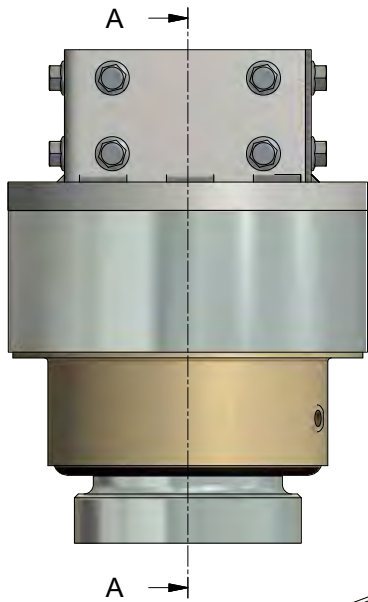
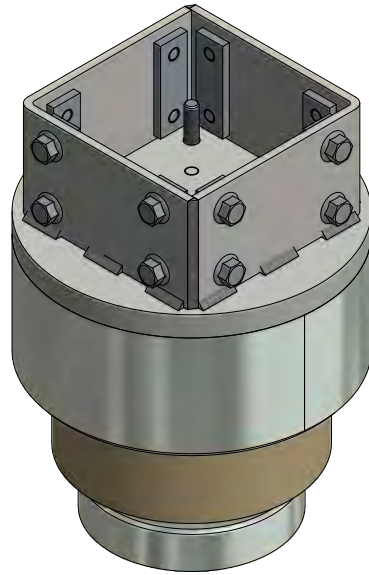

Tool adapter	739853
Weight kg	15,0

739857 Shaft bearing assembly

#	Article nr.	Designation	Quantity
1	739855	Turned shaft with flange	1
2	731434	Conical roller bearing	1
3	731436	Conical roller bearing	1
4	731435	Sealing	1
5	731437	Sealing	1
6	731439	Shaft nut KM 7	1
7	731438	Locking washer MB 7	1
8	739854	Bearing housing with flange	1

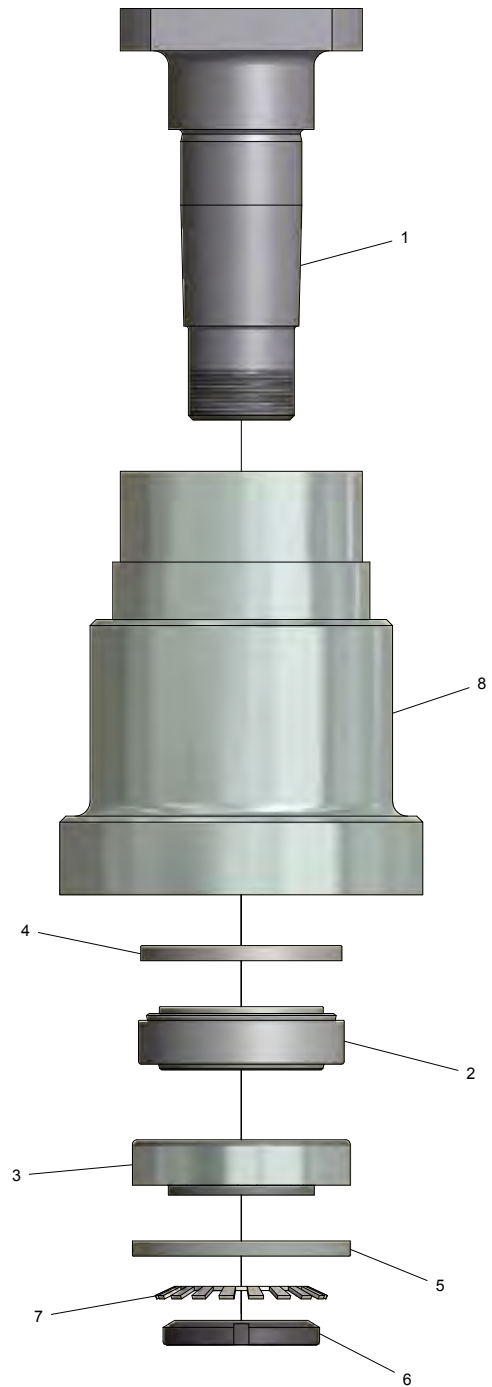
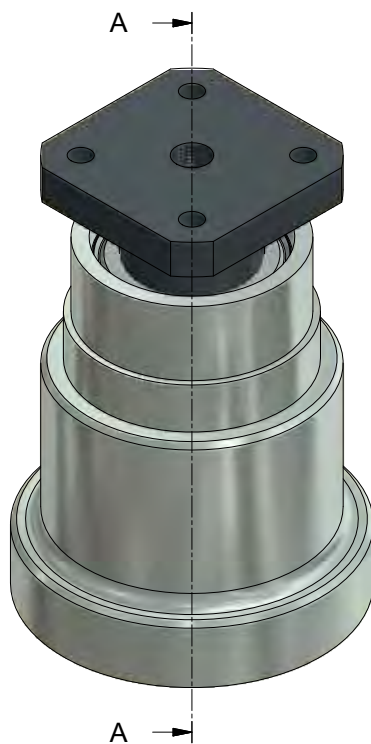
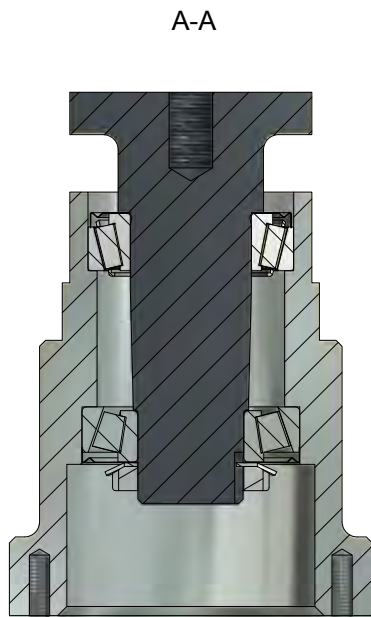

4. Control units

4.1 Overview of combinations



A	
74xxxx	1
742192	1



B	
74xxxx	1
742194	1

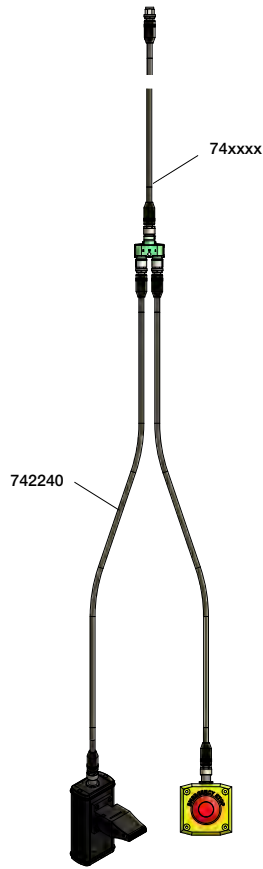

C	
74xxxx	1
742240	1



D	
74xxxx	1
742241	1



I	
74xxxx	1
742240	1
740457	1
742247	1



J	
74xxxx	1
742241	1
740457	1
742247	1

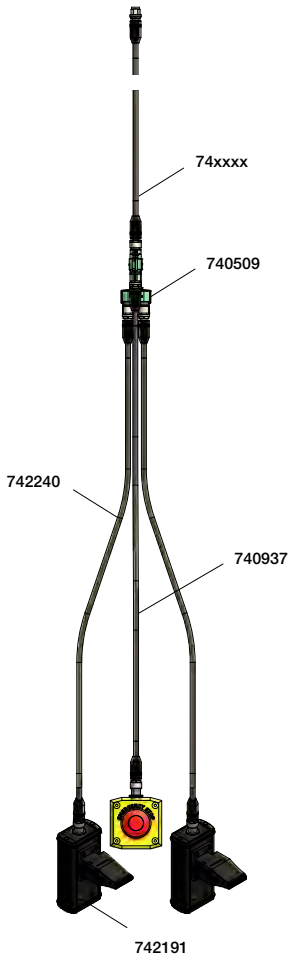

E	
74xxxx	1
740937	1
742240	1
742191	1
740509	1

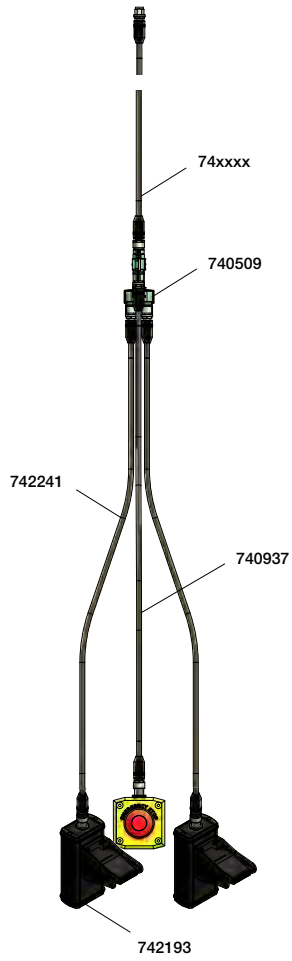

F	
74xxxx	1
740937	1
742241	1
742193	1
740509	1

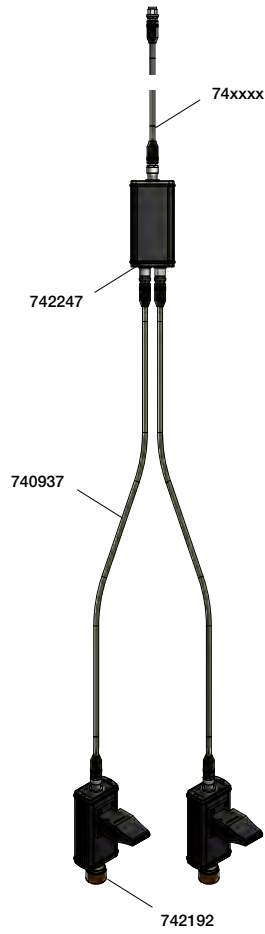

G	
74xxxx	1
740937	1
742192	2
742247	1

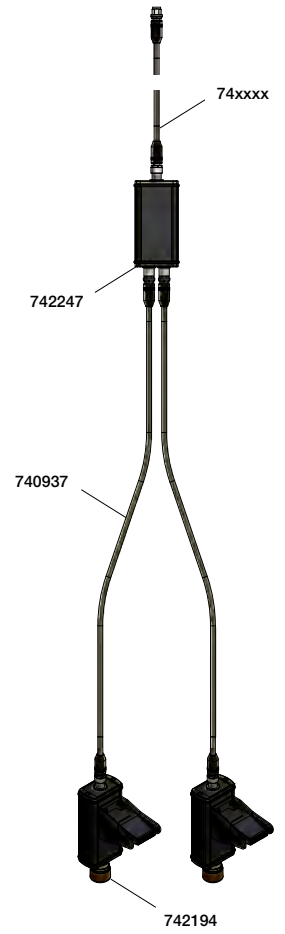

H	
74xxxx	1
740937	1
742194	2
742247	1

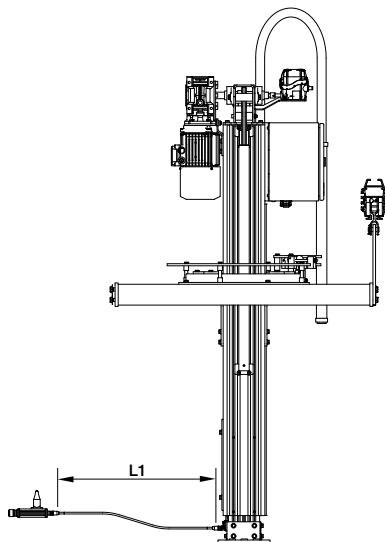

74xxxx	740937	741586	741678	741679	741680
Length L1 m	0,6	1,0	2,0	5,0	7,5

4.2 Control cable

74xxxx Cable, M12, 8 conductors, L=L1

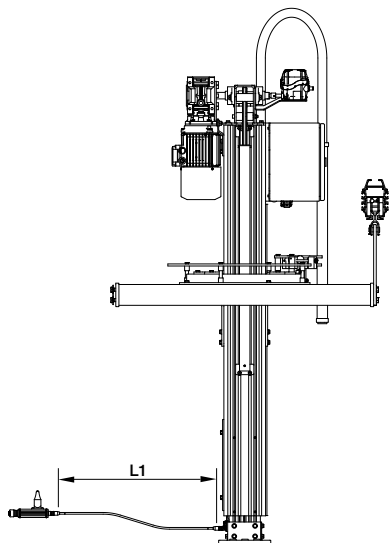

74xxxx	740937	741586	741678	741679	741680
Length L1 m	0,6	1,0	2,0	5,0	7,5

4.3 Control units

742240 Control unit external emergency stop			
#	Article nr.	Designation	Quantity
1	742191	Control unit	1
2	740457	Emergency stop, complete	R
3	740509	Y split 8 pol	1
4	740937	Cable, M12, 8 conductors, 0,6 m	2

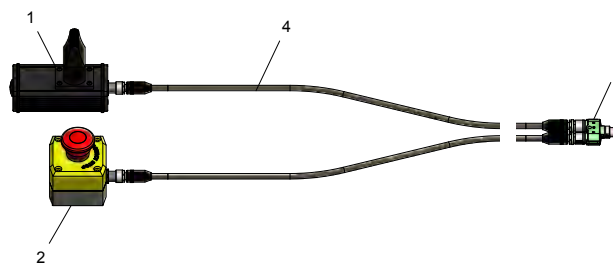

742241 Control unit with protection + ext. emergency stop			
#	Article nr.	Designation	Quantity
1	742193	Control unit with protection	1
2	740457	Emergency stop, complete	R
3	740509	Y split 8 pol	1
4	740937	Cable, M12, 8 conductors, 0,6 m	2

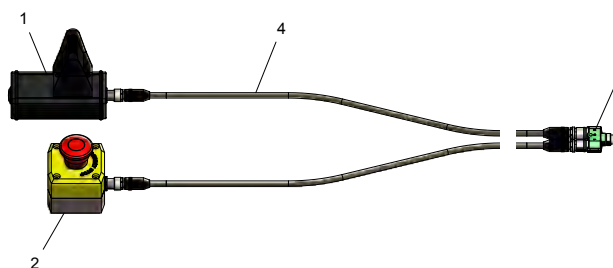

740457 Emergency stop, complete

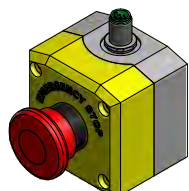

740509 Y split 8 pol

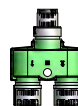

742192 Control unit with emergency stop

#	Article nr.	Designation	Quantity
1	742185	Joystick box	1
2	742184	Counterplate	1
3	742248	Gable M16x1.5	1
4	742188	Gable Ø16,2 mm	1
5	731740	Emergency stop assembly	1
6	732307	Joystick JC100	R 1
7	731522	Screw K6S M3x12 black	3
8	742265	Screw K6S M3x16 black	1
9	742257	PCB	1
10	740827	Flange plug M12 4 pol male	1

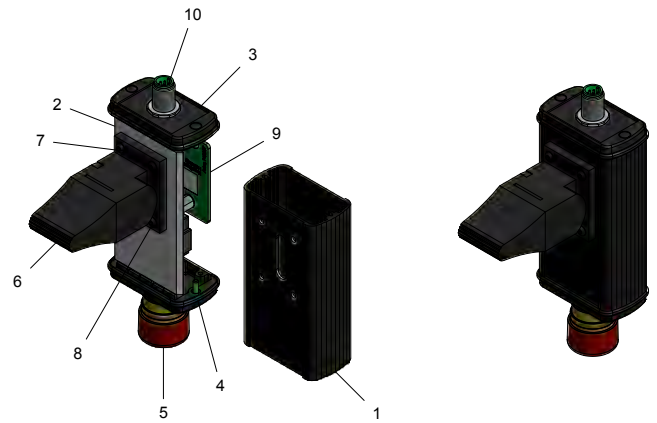

742194 Control unit with protection + emergency stop

#	Article nr.	Designation	Quantity
1	742185	Joystick box	1
2	742184	Counterplate	1
3	742248	Gable M16x1.5	1
4	742188	Gable Ø16,2 mm	1
5	731740	Emergency stop assembly	1
6	732307	Joystick JC100	R 1
7	731522	Screw K6S M3x12 black	3
8	742265	Screw K6S M3x16 black	1
9	742182	Protection plate	1
10	742257	PCB	1
11	740827	Flange plug M12 4 pol male	1

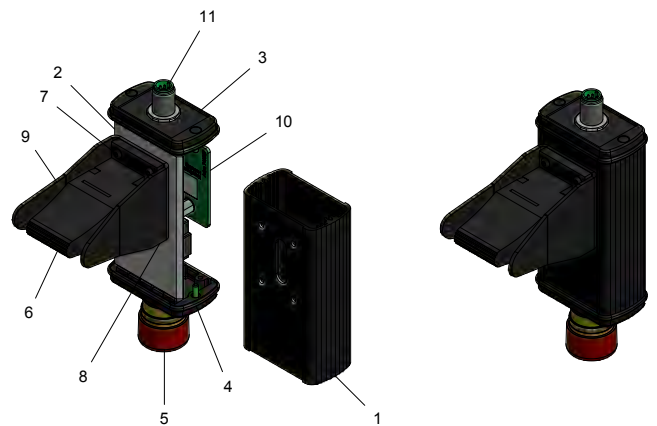

742191 Control unit

#	Article nr.	Designation	Quantity
1	742185	Joystick box	1
2	742184	Counterplate	1
3	742248	Gable M16x1.5	2
4	732307	Joystick JC100	R 1
5	742238	Blind plug M16	1
6	731522	Screw K6S M3x12 black	3
7	742265	Screw K6S M3x16 black	1
8	742257	PCB	1
9	740827	Flange plug M12 4 pol male	1

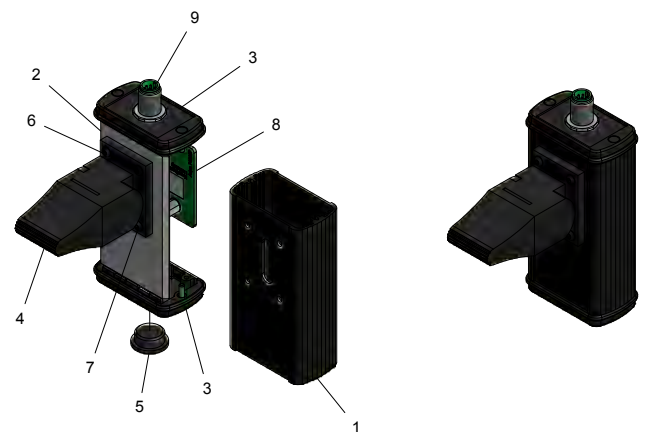

742193 Control unit with protection

#	Article nr.	Designation	Quantity
1	742185	Joystick box	1
2	742184	Counterplate	1
3	742248	Gable M16x1.5	2
4	732307	Joystick JC100	R 1
5	742238	Blind plug M16	1
6	731522	Screw K6S M3x12 black	3
7	742265	Screw K6S M3x16 black	1
8	742182	Protection plate	1
9	742257	PCB	1
10	740827	Flange plug M12 4 pol male	1

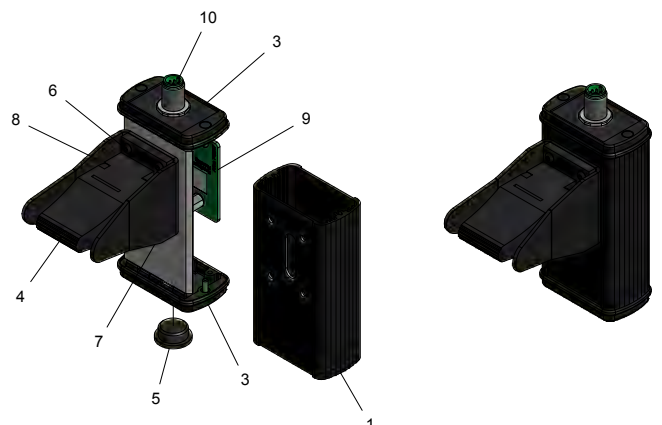

5. Accessories

5.1 Rotation brake

742708		Brake unit	
#	Article nr.	Designation	Quantity
1	742709	Brake caliper, sub-assy	R 2
2	730727	Screw MC6S M8x25	2
3	732373	Push-in L-fitting M5-4	1
4	735501	Screw MC6S M6x70	2
5	741361	Push-in T fitting M5-4	1
6	741898	Shim washer	1
7	730273	Locking nut M6	2

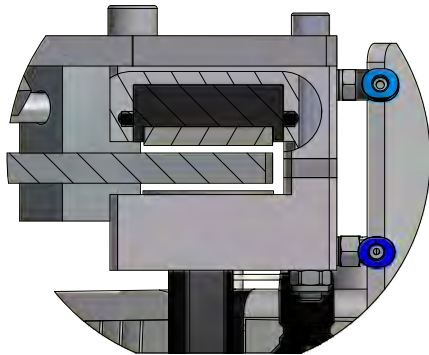
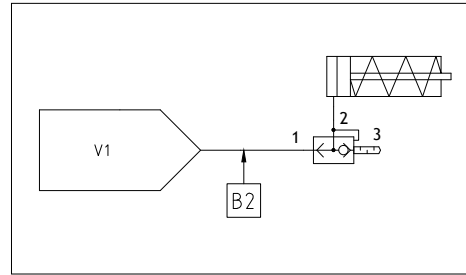

A

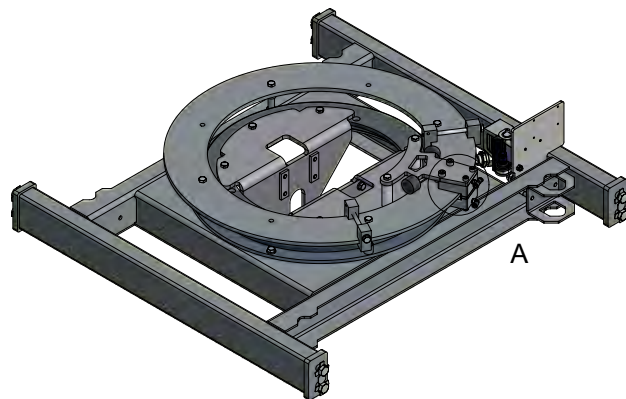
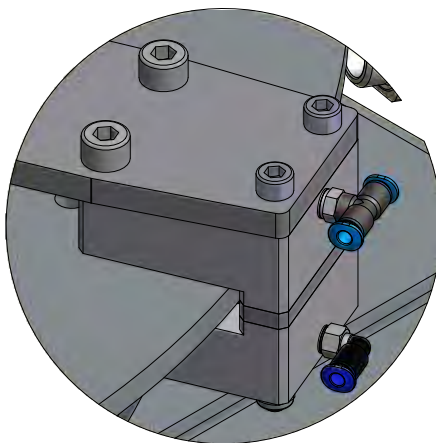
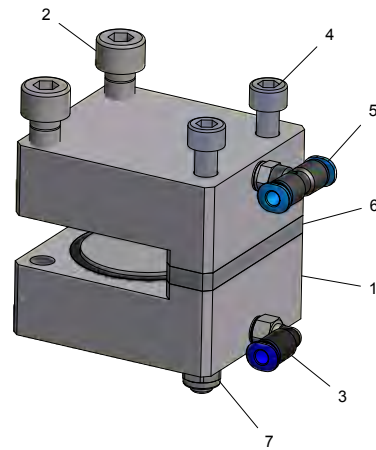

A

Brake unit	742708
Weight kg	0,4

5.2 Encoder

742256 Encoder

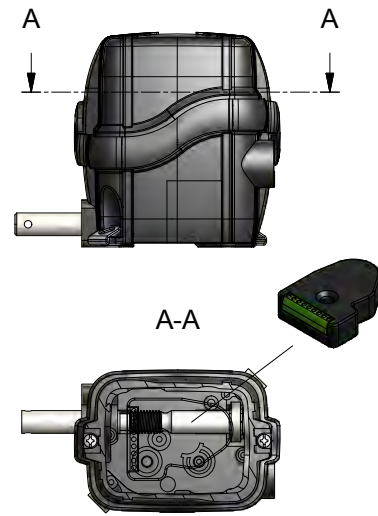
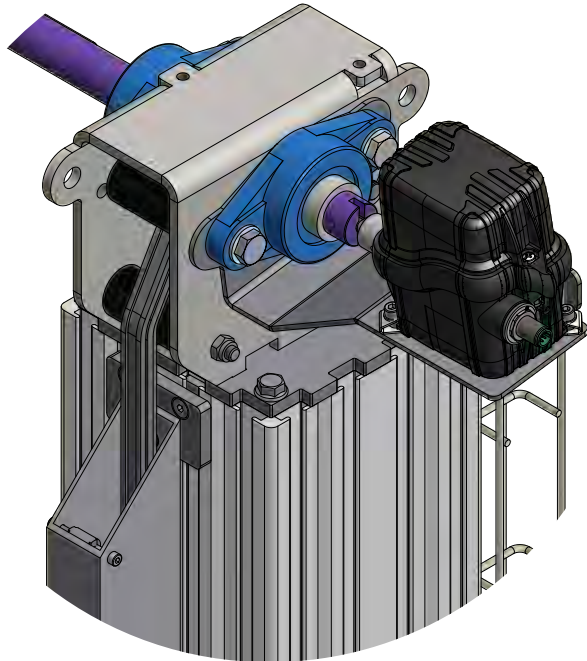

- The encoder simplifies positioning in the Z direction
- Mounted in the rotary limit switch.
- Teach-in function.
- Connected directly to Mechlift Pro (no external PLC required).

5.3 Brackets for control units

742242 Mounting clip

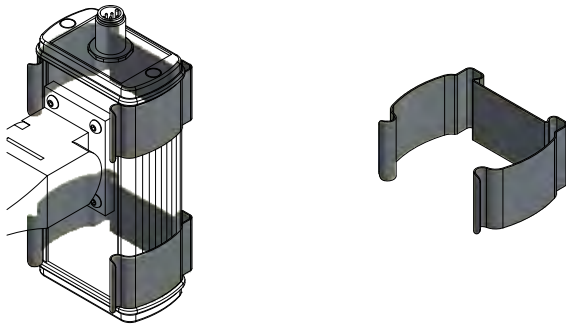

- Supplied individually.

742243 Wall bracket

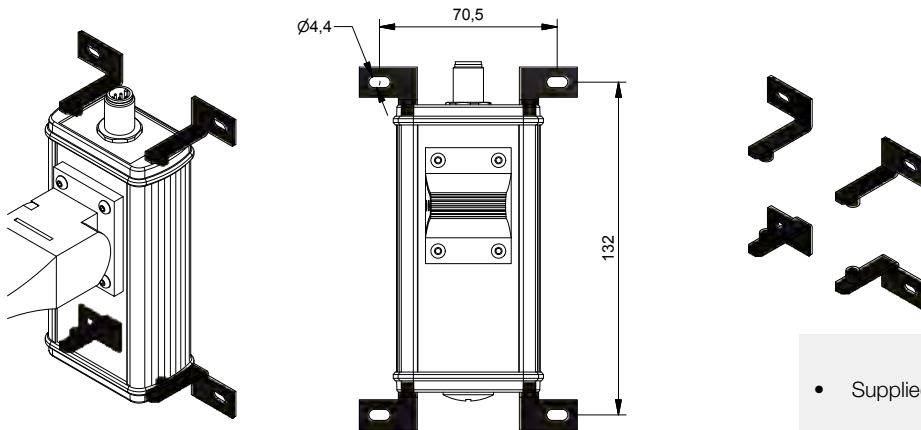

- Supplied in set (2x up + 2x down).

742244 Adjustable wall bracket

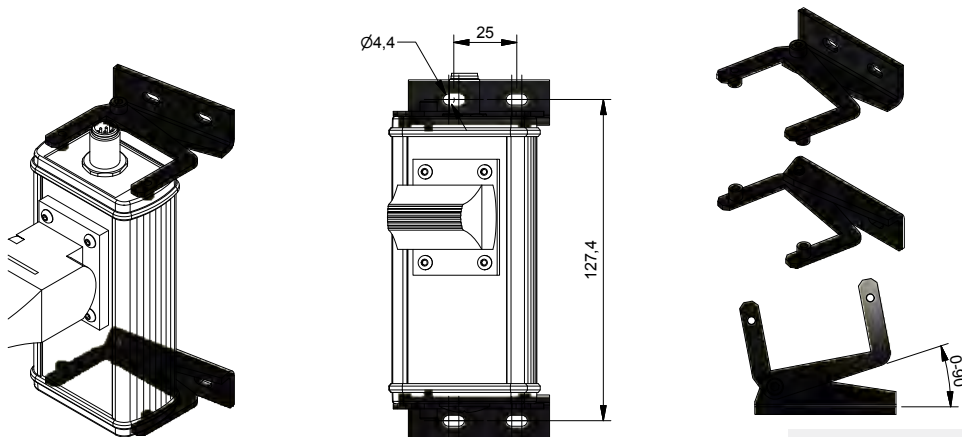

- Supplied in set (1x up + 1x down).

6. Circuit diagram and parameter settings

6.1 Circuit diagram Mechlift Pro

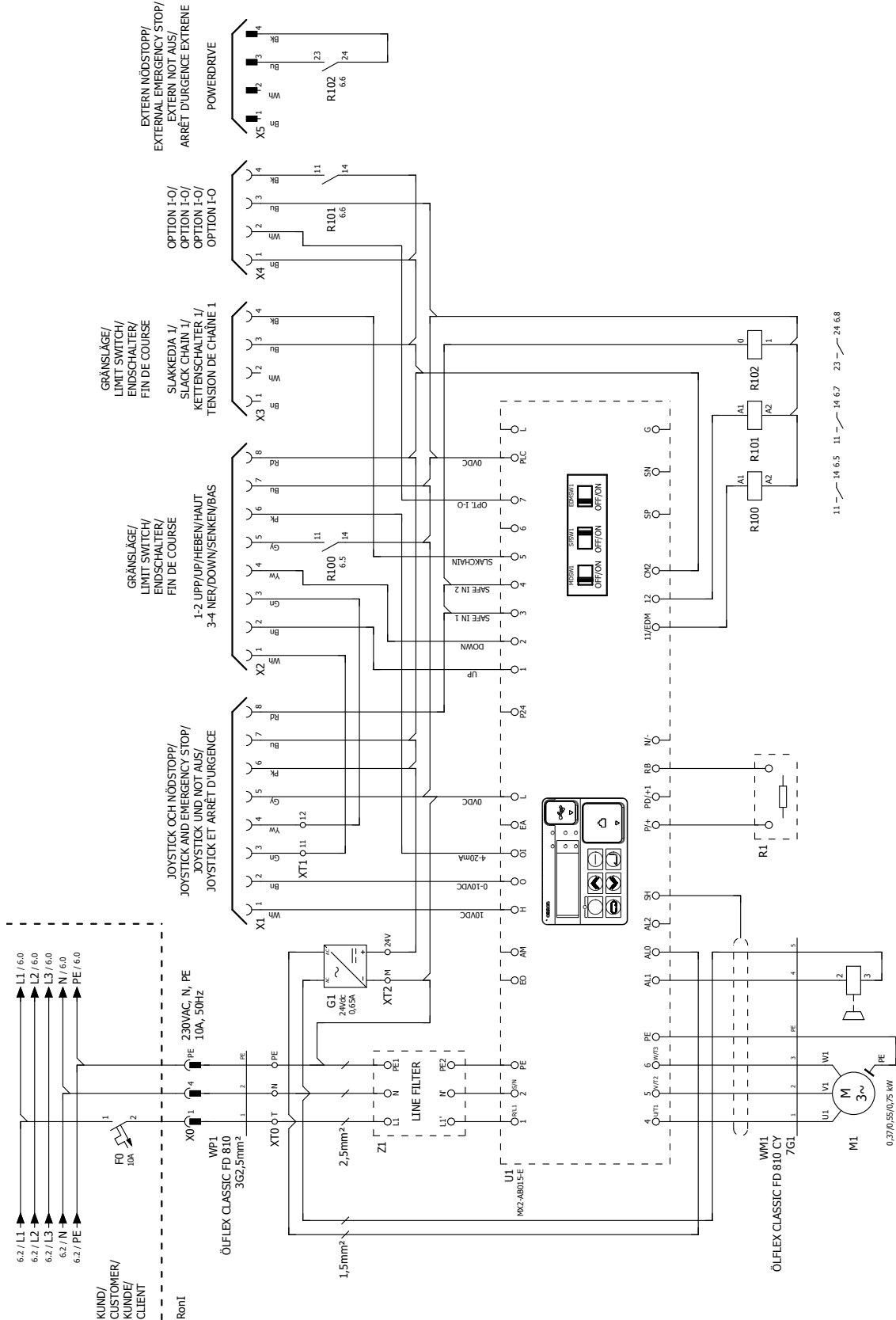

6.2 Circuit diagram control units

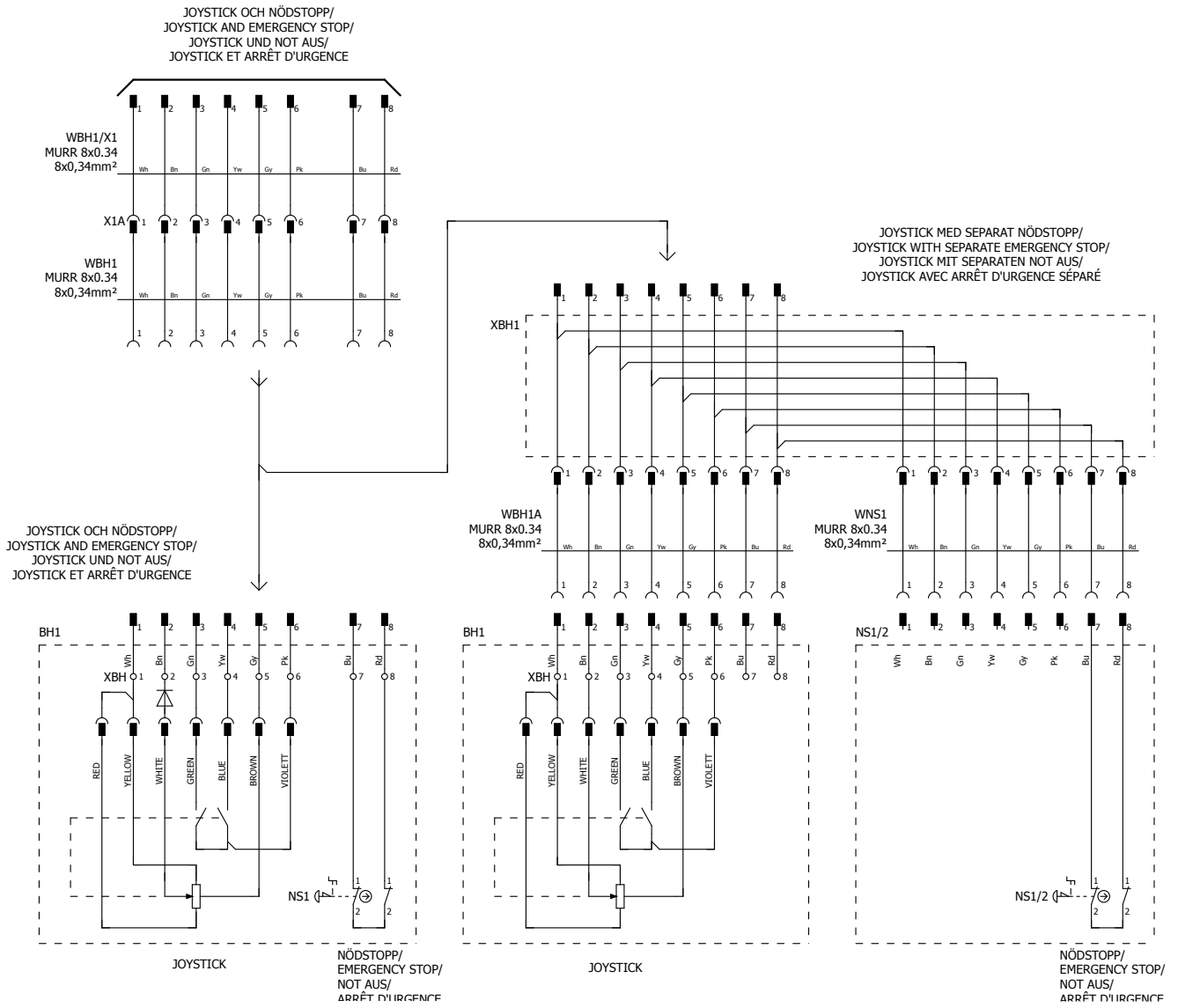

6.3 Circuit diagram limit switches

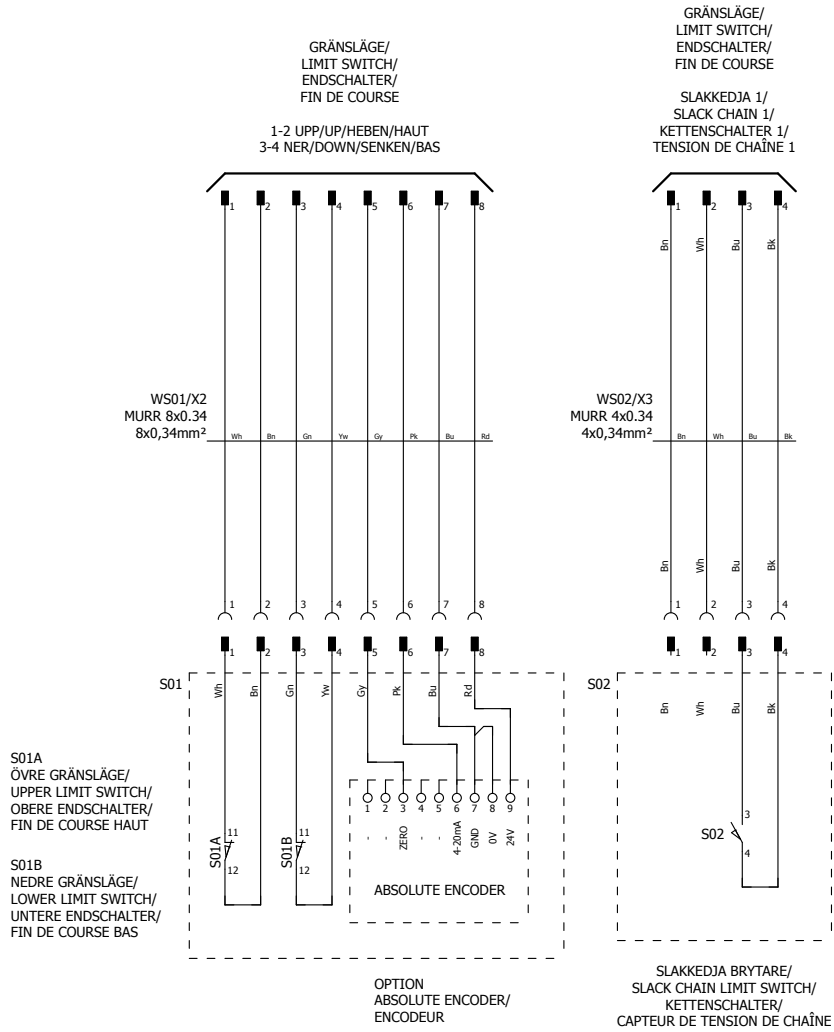

6.4 Electrical cabinet

742808 Electric cabinet 75-250 kg			
#	Article nr.	Designation	Quantity
1	740431	Electrical cabinet	1
2	742234	Braking resistor	R 1
3	742238	Blind plug M16	2
4	742231	Cable channel, L=30	1
5	731231	Cable fitting M20 EMC	1
6	733584	Cable fitting M16	1
7	733582	Cable fitting M20	1
8	736045	Cut over	1
9	733270	End plate	2
10	733265	End support	3
11	742223	Frequency inverter 0.75 kW	R* 1
12	742233	EMC filter	R 1
13	740830	Flange plug 4 pol female	3
14	742230	End plate	1
15	740829	Flange plug 8 pol female	1
16	740486	Flange plug 4 pol male	1
17	742225	Power supply 24 VDC	R 1
19	742228	Terminal, blue	1
20	742229	Terminal, grey	1
21	732469	Terminal, blue	2
22	735332	Terminal, grey	3
23	736022	Terminal, PE	3
24	730892	DIN rail, L=68	1
25	730892	DIN rail, L=68	1
26	742292	Terminal relay 24 VDC	R 3

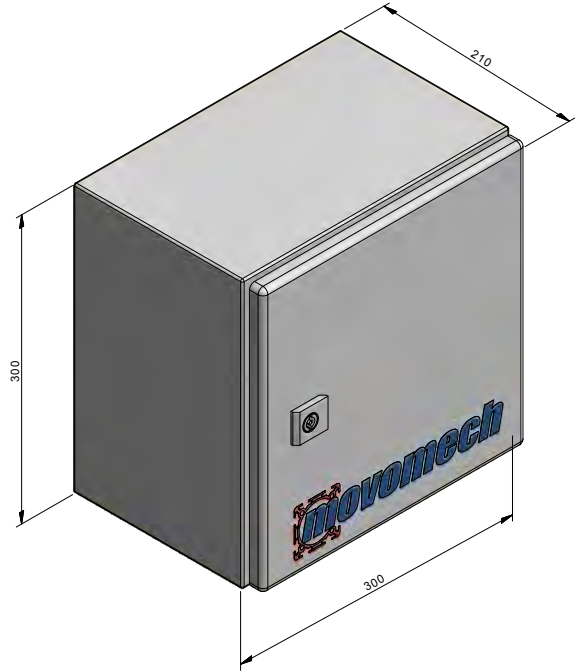

* When ordering as spare part, specify the lifter's serial number for the loading of correct parameters and program.

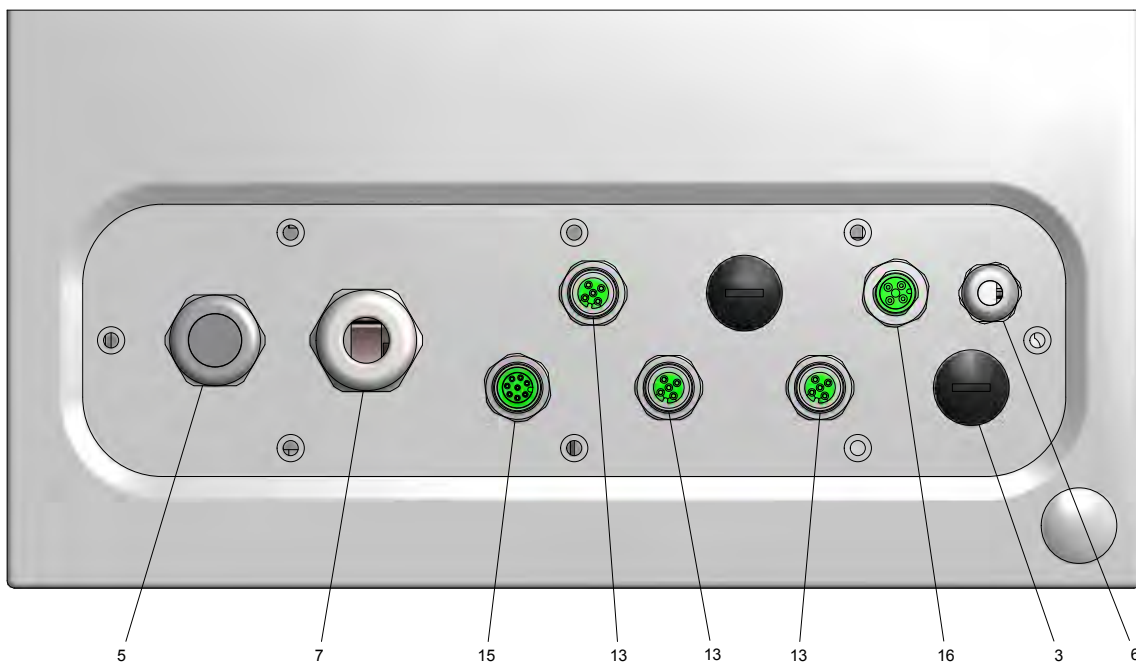

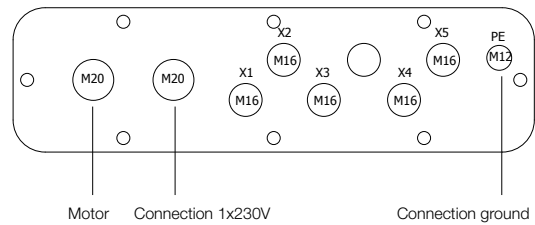
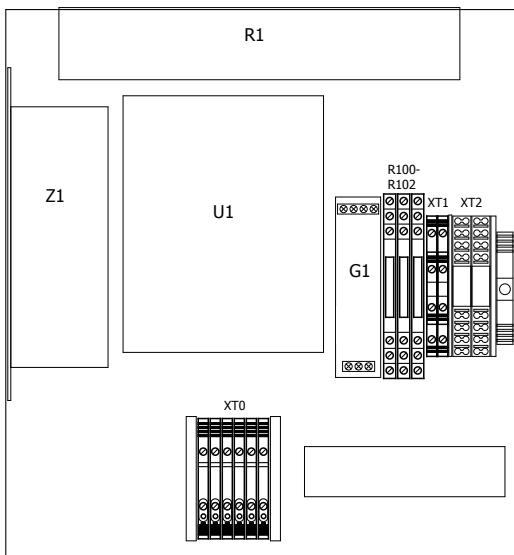
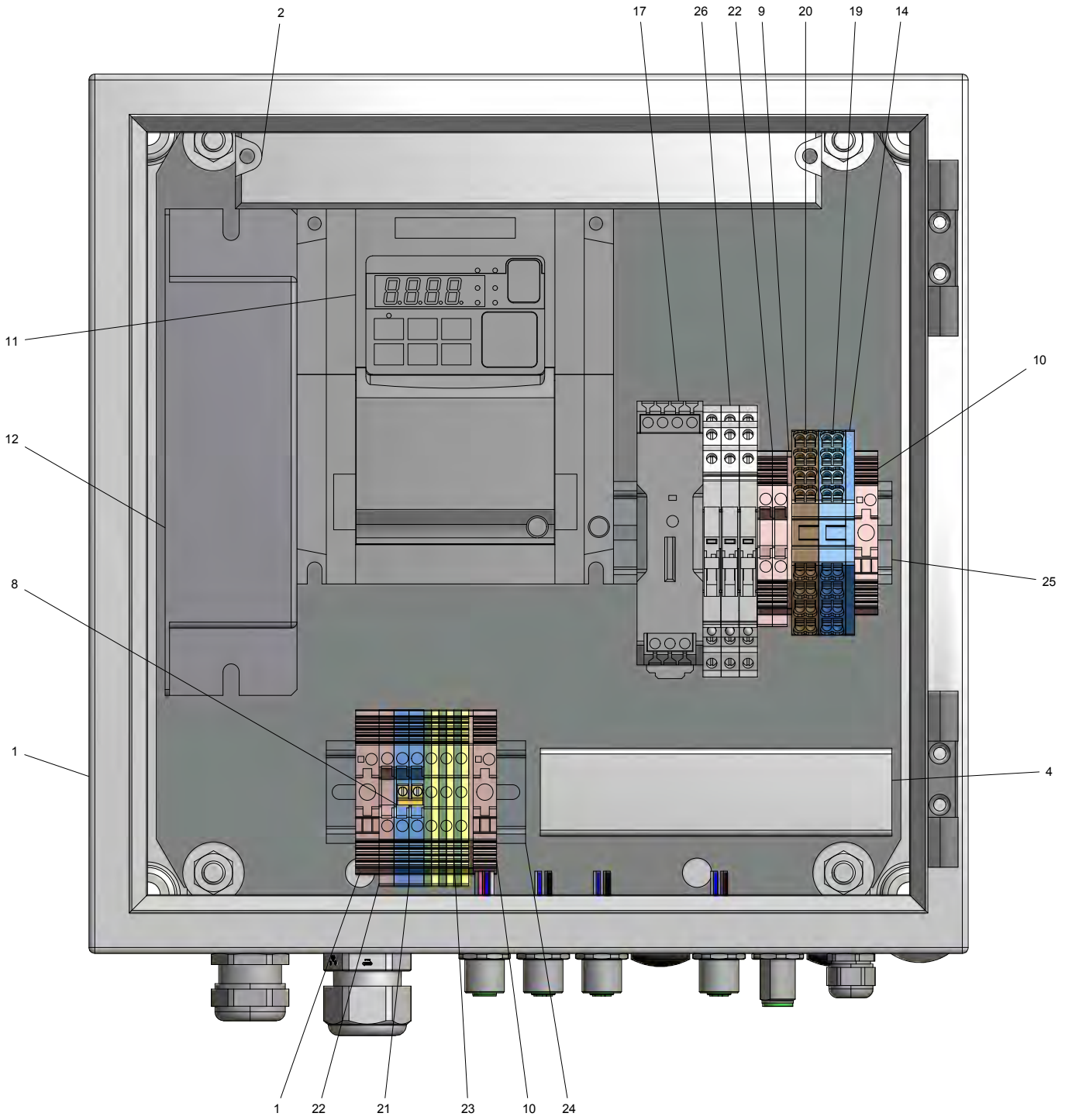

Position	Connection
X1	Control unit
X2	Rotary limit switch (upper/lower limit switch)
X3	Slack chain switch
X4	Option
X5	External emergency stop

6.5 Parameter settings 150/250 kg

Index	Description	Value	Default	Range	Units
A001	Frequency Reference Selection 1	7: Drive Programming	1	0 to 10	
A003	Base Frequency 1	50	120	30,0 to 100,0	Hz
A004	Maximum Frequency 1	100	120	50,0 to 400,0	Hz
A012	O End Frequency	95	0	0,00 to 400,00	Hz
A013	O Start Ratio	6	0	0 to 94	%
A014	O End Ratio	94	100	6 to 100	%
A017	Drive Programming Selection	2: Always	0	0 to 2	
A044	Control Method 1	3: SLV (sensorless vector control)	0	0 to 3	
B012	Electronic Thermal Level 1	4	5	1,00 to 5,00	A
B022	Overload Limit 1 Level	6	7,5	1,00 to 10,00	A
B025	Overload Limit 1 Level 2	6	7,5	1,00 to 10,00	A
B038	Initial Screen Selection	2: d002 - Output current monitor	1	0 to 202	
B041	Torque Limit 1 (Four-quadrant Mode Forward Power Running)	35 (150 kg), 70 (250 kg)	200	0 to 255	%
B083	Carrier Frequency	15	10	2,0 to 15,0	kHz
B090	Usage Rate of Regenerative Braking	15	0	0,0 to 19,6	%
B095	Regenerative Braking Selection	1: Enabling [disabling while the motor is stopped]	0	0 to 2	
B097	BRD Resistor Value	70	50	50,0 to 600,0	Ohm(s)
B164	Initial Screen Automatic Switching Function	1: Enabled	0	0 to 1	
B212	Electronic Thermal Level 2	3	5	1,00 to 5,00	A
B222	Overload Limit 2 Level	4,5	7,5	1,00 to 10,00	A
C001	Multi-function Input [1] Selection	56: X(00) Drive Programming (MI1)	0	0 to 255	
C002	Multi-function Input [2] Selection	57: X(01) Drive Programming (MI2)	1	0 to 255	
C003	Multi-function Input [3] Selection	77: GS1 (GS1 input)	12	0 to 255	
C004	Multi-function Input [4] Selection	78: GS2 (GS2 input)	18	0 to 255	
C005	Multi-function Input [5] Selection	60: MI5 (General-purpose input 5)	2	0 to 255	
C006	Multi-function Input [6] Selection	61: X(05) Drive Programming (MI6)	3	0 to 255	
C007	Multi-function Input [7] Selection	62: X(06) Drive Programming (MI7)	6	0 to 255	
C013	Multi-function Input Terminal [3] Operation Selection	1: NC	0	0 to 1	
C014	Multi-function Input Terminal [4] Operation Selection	1: NC	0	0 to 1	
C021	Multi-function Output Terminal [11]/EDM Selection	255: no (Not used)	0	0 to 255	
C022	Multi-function Output Terminal [12] Selection	255: no (Not used)	1	0 to 255	
C026	Multi-function Relay Output (AL2, AL1) Function Selection	2: FA2 (Frequency Arrival Type 2 - Over Frequency)	5	0 to 255	
C030	Digital Current Monitor Reference Value	3	5	1,00 to 10,00	A
C036	Multi-function Relay Output (AL2, AL1) Contact Selection	0: NO	1	0 to 1	
C039	Low Current Detection Level	3	5	0,00 to 10,00	A
C041	Overload Warning Level 1	3,45	5,75	0,00 to 10,00	A
C042	Arrival Frequency During Acceleration	1	0	0,00 to 400,00	Hz
C043	Arrival Frequency During Deceleration	1	0	0,00 to 400,00	Hz
C081	O Adjustment	125	100	0,0 to 200,0	
C091	Debug Mode Selection	1: Enabled	0	0 to 1	
C111	Overload 1 Warning Level 2	3,45	5,75	0,00 to 10,00	A
C241	Overload Warning Level 2	3,45	5,75	0,00 to 10,00	A
F002	Acceleration Time Setting 1	1	10	0,00 to 3600,00	sec
F003	Deceleration Time Setting 1	0,3	10	0,00 to 3600,00	sec
F202	Acceleration Time Setting 2	2	10	0,00 to 3600,00	sec
F203	Deceleration Time Setting 2	0,5	10	0,00 to 3600,00	sec
H002	Motor Parameter 1	2: Auto-tuned data	0	0 to 2	
H005	Speed Response 1	250	100	1 to 1000	
H030	Motor 1 Parameter R1 (Auto-tuning Data)	3,585	2,984	0,001 to 65,535	Ohm(s)
H031	Motor 1 Parameter R2 (Auto-tuning Data)	2,092	1,448	0,001 to 65,535	Ohm(s)
H032	Motor 1 Parameter L (Auto-tuning Data)	30,88	12,97	0,01 to 655,35	mH
H033	Motor 1 Parameter Io (Auto-tuning Data)	2,73	1,96	0,01 to 655,35	A
H034	Motor 1 Parameter J (Auto-tuning Data)	0,005	0,009	0,001 to 9999,000	kgm ²

Index	Description	Value	Default	Range	Units
H203	Motor Capacity 2	2: 0.40	4	0 to 15	kW
H230	Motor 2 Parameter R1 (Auto-tuning Data)	5,877	2,984	0,001 to 65,535	Ohm(s)
H231	Motor 2 Parameter R2 (Auto-tuning Data)	2,659	1,448	0,001 to 65,535	Ohm(s)
H232	Motor 2 Parameter L (Auto-tuning Data)	37,03	12,97	0,01 to 655,35	mH
H233	Motor 2 Parameter Io (Auto-tuning Data)	1,73	1,96	0,01 to 655,35	A
H234	Motor 2 Parameter J (Auto-tuning Data)	0,005	0,009	0,001 to 9999,000	kgm ²
P031	Acceleration/Deceleration Time Input Type	3: Drive Programming	0	0 to 3	

7. Installation and commissioning

7.1 Mechanical installation

Mechlift Pro is advantageously installed in aluminium rail system Mechrail.

1. Verify that the rail system is dimensioned for the total load including dynamic effects.
2. Check that end stops are mounted in all end points on the track and crane.
3. Install suspensions on Mechlif Pro if they are not already mounted.
4. Lock all rotation stops at top and bottom.
5. Raise Mechlif Pro by using a forklift, or by winch/hoist.
6. Install the suspensions into the trolleys.

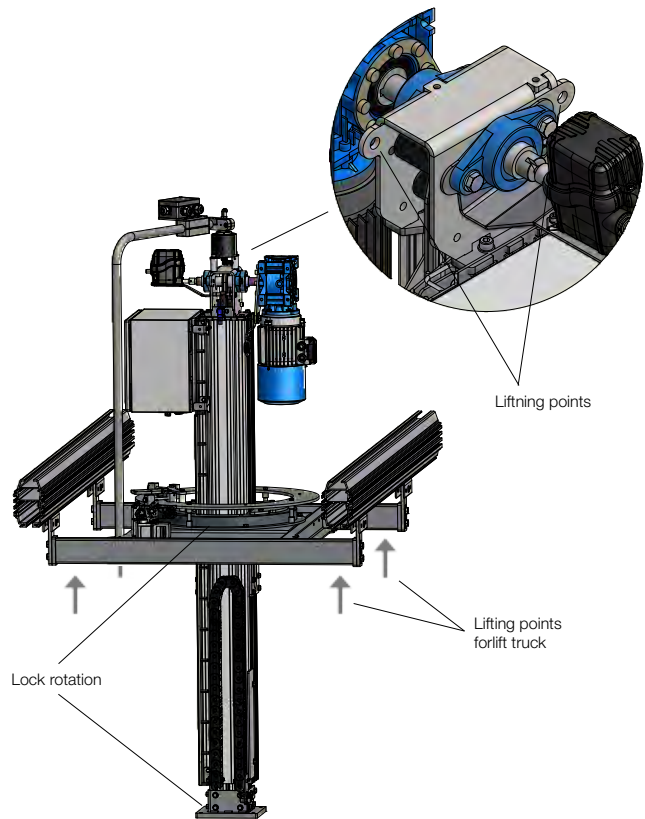

7.2 Electrical installation

Electric Mechlif Pro must be connected only to 1x230V, N, PE (± 15) 50/60 Hz.

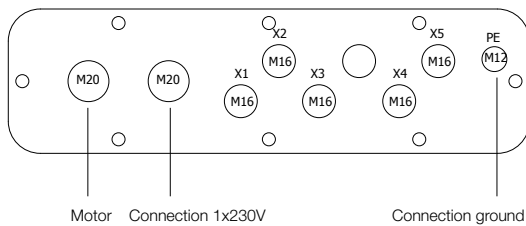

7.3 Setting of encoder (option)

Electric Mechlif Pro may optionally be equipped with an encoder that reads the axle in the spindle limit switch. This makes it possible to set a lower stop position, as well as a further two stop/start positions along the stroke.

The positions are stored in a built in memory in the frequency converter and are not erased in case of power cuts. It is possible to adjust the height several times by following the same procedure. The stop/start position when moving upwards may be at the same height as for the downwards movement.

Please note: The encoder never replaces the end limit switches! It is only to be used as a complementary tool to facilitate for the operator to stop the lifting movement at pre-set positions.

Resetting the encoder (when changing/at first installation)

1. Use the joystick to drive Mechlif Pro to the top position (the upper spindle limit switch stops the lifting movement).
2. Go to parameter P128 on the frequency converter, and set the value = 1.
3. Wait 10 seconds.
4. The encoder is now reset.

Setting the lower stop position

1. Use the joystick to drive Mechlif Pro to the desired lower stop position.
2. Go to parameter D25 on the frequency converter and read the value (0-9999).
3. Go to parameter P129 and set the value = the value from D25.

Please note: Parameter P129 must be more than 0000 if the other positions are to be used. The function is deactivated by setting the value to = 0000.

Setting the stop/start position for an upward movement

Manual setting (alternative 1):

1. Use the joystick to drive Mechlif Pro to the desired stop position.
2. Activate the emergency stop.
3. Press the joystick upwards for 20 seconds.
4. Release the joystick and reset the emergency stop.

Via the frequency converter (alternative 2):

1. Use the joystick to drive Mechlif Pro to the desired stop position.
2. Go to parameter D25 on the frequency converter and read the value (0-9999).
3. Go to parameter P131 and set the value = the value from D25.

Setting the stop/start position for an downward movement

Manual setting (alternative 1):

1. Use the joystick to drive Mechlif Pro to the desired stop position.
2. Activate the emergency stop.
3. Press the joystick downwards for 20 seconds.
4. Release the joystick and reset the emergency stop.

Via the frequency converter (alternative 2):

1. Use the joystick to drive Mechlif Pro to the desired stop position.
2. Go to parameter D25 on the frequency converter and read the value (0-9999).
3. Go to parameter P130 and set the value = the value from D25.

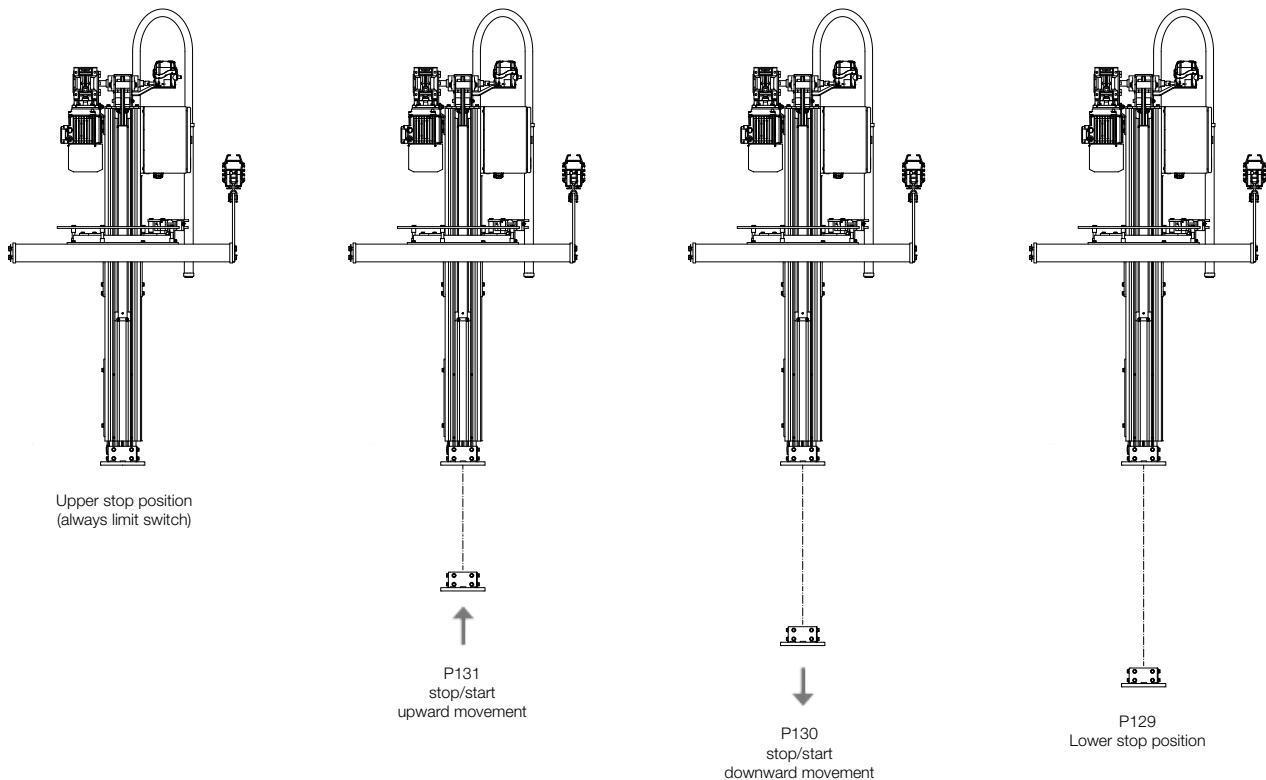

8. User instructions

Mechlift Pro is intended for use in combination with a gripping tool for a smooth and ergonomic material handling.

The operation of electric Mechlif Pro is largely dependent on its specific application:

- its configuration
- gripper design and functionality
- characteristics and variability of the handled object
- the surrounding work environment
- intended work pace as well as usage frequency

A complete workstation, including Mechlif Pro, must be accompanied by a specific operating instruction for the particular application, taking into account the mentioned factors.

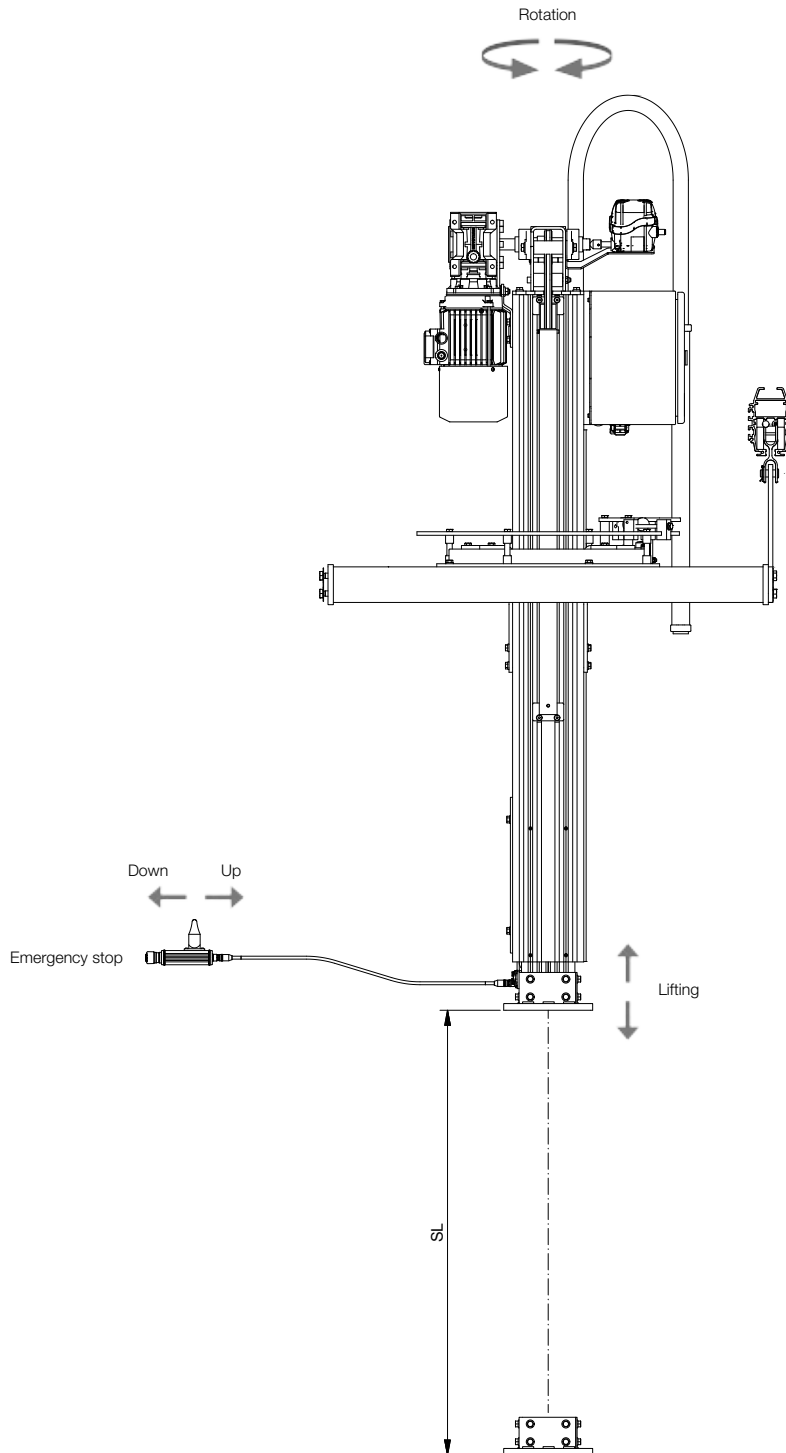

9. Service, maintenance & running

A general review and functional control tests are performed on a regular basis during commissioning.

All service and maintenance shall be recorded. The user should make sure that material for the purpose is easily available.

NOTE: Make sure that damaged components are replaced immediately in order to avoid possible personal and material damage.

Keep the equipment and area on and adjacent to the workplace cleaned. This is important for the comfort and well-being of personnel and facilitates service and maintenance. Dirt gives a clear indication of the equipment not being properly maintained, which may possibly affect the remaining guarantees on the equipment.

Maintenance safety instructions

The prescribed procedures and service intervals, including those concerning the replacement of parts/accessories, are described in the instruction manual and must be followed. Professionals are the only persons who are allowed to carry out such procedures.

Staff members with appropriate competence and authority are the only persons who are allowed to carry out mechanical and electrical repair and maintenance work. Unauthorised persons should be prohibited to work with machines and devices inside the equipment.

The equipment should be disconnected and secured against unintentional or unauthorised use, including reconnection, during all repair and maintenance work.

It should be confirmed that the equipment is free from voltage before any work on electric equipment is commenced.

Make sure that:

- moving parts are stationary and locked, and that
- moving parts cannot move accidentally during maintenance work.

Use safe and environmentally friendly maintenance products and spare parts!

Directions for work during operation

The user or the "authorised person" must, in each individual case, ensure that the work in question can be carried out without any risk of personal injury because of specific local conditions.

To prevent accidents, only approved and suitable tools and aids may be used during maintenance, adjustment and repair work.

Do not touch rotating parts. Maintain an adequate safe distance between yourself and the machinery to prevent clothes, limbs and hair from becoming caught.

Avoid the occurrence of naked flame, extreme heat (e.g. welding) and sparks in the presence of volatile cleaning materials and nearby inflammable or heat-sensitive materials (e.g. wood, plastics, oils, fats and electric equipment). This can result in fire hazard, harmful gases and damaged insulation.

Directions for work with electric equipment

Use only original fuses with the appropriate rating. The equipment should be stopped immediately on discovery of faults related to the electric power supply.

Defect fuses must not be repaired or bypassed and should only be replaced with fuses of the same kind.

Work on electric equipment and electric components or parts must be carried out by an electrician or authorised staff in accordance with current electric safety regulations.

The parts of the equipment on which inspection, maintenance, and repair work is to be carried out should be disconnected from the power supply.

The electrical equipment should be inspected regularly. Deficiencies, such as loose connections, should be rectified without delay.

When it is necessary to work with live parts, a second member of staff, whose responsibility it is to activate the emergency stop and deactivate the main switch in case of an emergency, should be called in. Isolate the work area with a red/white chain or tape and warning signs. Use only voltage-insulated tools.

Electric connectors must be free of voltage (exemptions include socket-outlets, unless safety precautions state that these are dangerous to be in contact with) before they are disconnected or connected.



Keep the equipment and area on and adjacent to the workplace cleaned.

9.1 Recommended spare parts / wear parts

7427xx Pillar unit 150/250 kg				
#	Article nr.	Designation	Quantity	
8	730735	Sliding block MK40 L=30	S	16
42	731261	Roller chain Simplex 1/2", L=L6	S	1
43	733239	Cable chain 10.0.40	R	L7

Pillar unit							
		742716	742717	742718	742719	742720	742721
Stroke SL	mm	500	750	1000	1250	1500	500-1500
Length L7	mm	875	1085	1365	1575	4120	SL+365

731263 Cush drive M16x1.5 Simplex 1/2"				
#	Article nr.	Designation	Quantity	
-	731269	Cylindrical pin with cotter pin	R	1

742760 Housing assembly 150/250 kg				
#	Article nr.	Designation	Quantity	
2	742782	Chain sprocket Simplex 1/2"	S	1
3	742211	Slack chain switch	R	1
4	742255	Rotary limit switch	R	1
19	742768	Slide block	S	1

742808 Electric cabinet 75-250 kg				
#	Article nr.	Designation	Quantity	
2	742234	Braking resistor	R	1
11	742223	Frequency inverter 0.75 kW	R*	1
12	742233	EMC filter	R	1
17	742225	Power supply 24 VDC	R	1
26	742292	Terminal relay 24 VDC	R	3

* When ordering as spare part, specify the lifter's serial number for the loading of correct parameters and program.





























































742741/-2 Engine unit				
#	Article nr.	Designation	Quantity	
1	742175	Worm gear motor 0.75 kW	R	1

739852/-3 Drehlagerung MP120 / Bremse				
#	Artikel-Nr.	Benennung	Anzahl	
10	731492	Dämpfer	S	1

742708 Brake unit				
#	Article nr.	Designation	Quantity	
1	742709	Brake caliper, sub-assy	R	2

742xxx Control unit				
#	Article nr.	Designation	Quantity	
-	732307	Joystick JC100	R	1

9.2 Service record – Mechlift Pro 150/250 electric

ID: Service by:		Client/ place: Date:	Interval in months when 1-3 shifts	Interval in months when >3 shifts	The service record shall be archived by the client/user.	1/2		
	Visual inspection, examine whether the product exhibits damages						* If applicable. Tests are to be performed with unloaded gripper tool. The service must be performed considering the maintenance safety instruction.	
	Auditory inspection, examine whether the product exhibits discordant sound							
	Physical inspection, examine whether the product exhibits damages							
	Mechanical inspection, examine whether the product exhibits decomposition, instruments is needed							
No	Product	Inspection			Inspector Dept. / Sign.	Comment		
1	<u>Cross unit</u>	    General overview.	4	3				
1.1	Fasteners	  	4	3				
1.2	Swivel ring*	  	4	3				
1.3	Rotation limiters*	  	4	3				
2	<u>Pillar unit</u>	    General overview.	4	3				
2.1	Fasteners	  	4	3				
2.2	Cable chain	   	4	3				
2.3	Sliding blocks	   Check that the inner pillar is stable and only allows little lateral movement, indicating that the sliding blocks are in good condition. If necessary, replace the sliding blocks according to a specific instruction.	4	3				
2.4	Roller chain	    Check if the chain is lubricated. Recommended lubricants: KLÜBER: Structovis FHD KLÜBERSYNTH: CH 2-100 N (spray) Chain sprocket and roller chain are evaluated at the same time.	4	3				
2.5	Cush drive	    Check the cush drive for damages.	12	12				
3	<u>Engine unit</u>	    General overview.	4	3				
3.1	Fasteners	  	4	3				
3.2	Motor	    Check if gear box is leaking. Check cabling and connections. Test: Drive the hoist up and down, the motor must respond instantly when joystick is affected. Run both top speed and slow speed.	4	3				
3.3	Bearings	   	4	3				
3.4	Chain sprocket	   Check for abnormal wear. Chain wheel and roller chain are evaluated at the same time.	4	3				
3.5	Electric cabinet	   Check cabling and connections.	4	3				

ID: Service by:		Client/ place: Date:	Interval in months when 1-3 shifts	Interval in months when >3 shifts	The service record shall be archived by the client/user.	2/2
Visual inspection, examine whether the product exhibits damages		* If applicable. Tests are to be performed with unloaded gripper tool. The service must be performed considering the maintenance safety instruction.				
Auditory inspection, examine whether the product exhibits discordant sound						
Physical inspection, examine whether the product exhibits damages						
Mechanical inspection, examine whether the product exhibits decomposition, instruments is needed						
No	Product	Inspection			Inspector Dept. / Sign.	Comment
3.6	Rotary limit switch	 Test: Drive the lifter up and down, the motor shall stop automatically in upper and lower positions. Note! The lifter motion must not be limited by any mechanical obstructions!	4	3		
3.7	Slack chain switch	 Check cabling and connections. Test: Drive the lifter downwards, the motor shall stop whenever the pillar is unloaded on a mechanical object.	4	3		
4	<u>Control unit(s)</u>	 General overview and function test: drive the lifter in all applicable situations.	4	3		
4.1	Joystick	 Test: Drive the lifter up and down, the motor must respond instantly when joystick is affected. Run both top speed and slow speed.	4	3		
4.2	Emergency stop	 Test: Drive the lifter up and down, activate the emergency stop button, the hoist must stop instantly when the button is activated. The button must remain activated after being affected (reset by turning button).	4	3		
5	<u>Tool adapter</u>	 General overview and check fasteners and rotation stop dampers.	4	3		
6	<u>Brakes*</u>	 General overview and function test.	4	3		

9.3 Chain and chain sprocket

Lubrication instructions

The chain transmission should be protected from pollution and damp, and should be adequately lubricated using a petroleum-based oil of high quality without detergent.

Viscous oils and fats usually have problems penetrating the chain's operational parts and should therefore not be used.

It is particularly important that the oil reaches the chain's bearing surfaces by directing the oil at the gaps between the chain's inner and outer connecting plates.

Lubrication method

The oil is applied periodically using a brush or a lubricating can; the amount of oil and number of lubrications have to be adjusted so that the chain is permanently moist with clean oil penetrating the chain links.

Satisfactory lubrication can also be accomplished using an aerosol spray, but it is important that the aerosol type has been approved for the application.

This type of lubrication penetrates the area between the pin, sleeve, and roll, and it does not drip or run when the chain is stationary. Furthermore, owing to its adhesivity it is not discarded during operation when it moves across the pinion.

Measuring chain wear

The elongation of the chain's nominal length is a direct measurement of chain wear. Thus, the amount of wear can be determined through measuring the length according to the following instructions.

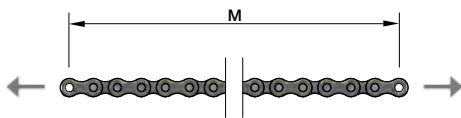

Measured length 'M' in mm.

- The nominal chain length over 11 links is 127 mm.
- The result of measuring the chain length over 11 links as shown in the illustration may not exceed 129,5 mm.
- As a general rule the chain is worn-out and should be replaced when the elongation expressed as a percentage reaches 2%.

Reparation/replacement of chain and chain sprocket

As a rule the chain does not have to be repaired. A chain with correct dimensions that has been maintained properly will wear down successively throughout its life and should last for approximately 15,000 hours of operation without breaking down.

In order to determine the chain's remaining length of service, it is necessary to perform an inspection of the chain's elongation.

A damaged transmission chain with damage caused by overloading, tugging, or climbing on the chain wheel teeth should be taken out of operation and examined thoroughly. Remove all lubrication in order to make the process easier.

Depending on the nature of the damage, it may be practical to carry out temporary repairs by replacing only a few links.

However, the chain may be fatigued and therefore more likely to become damaged at a later stage.

In order to avoid further disruption to operations we recommend that a new chain be fitted.

If a chain has broken down twice or more it will definitely break down again in the near future. If no replacement chain is available immediately, the chain should be repaired and then replaced as soon as possible.

The chain should be replaced in its entirety for the following reasons:

- The costs associated with standstills often exceed those associated with chain replacement.
- Broken down chains that are repaired with new parts of chains or used chains and links cause tugging and load pulsation. This results in further breakdown and accelerates the wear on both chain and wheel.

Personal safety regulations

The following precautionary actions must be taken before the chain is disconnected and removed from a transmission in connection with a chain replacement, repairs, or chain length alterations:

- Always disconnect the electric connection and the power sources of all other equipment.
- Always use protective glasses.
- Always use appropriate protective clothing, gloves and work shoes.
- Ensure that all tools are in good condition.
- Always loosen chucking devices.
- Support the chain in order to avoid sudden collapse of chain or other components.
- Never try to dismantle or connect a chain without being fully aware of the lifter's design and functions.
- Never reuse individual parts.
- Never reuse a damaged chain or chain component.

Recommended lubricants:

- Klüber Structovis FHD
- Klübersynth CH 2-100 N (spray)

9.4 Replacement of chain

1. Read through the section Chain and chain sprocket.
2. Drive Mechlif Pro to the upper and lowermost positions. Measure how much of the inner profile protrudes at the two end positions.
3. Run down the inner profile to the lowermost position. Make sure that it does not fall down during the service work by securing it on forklift forks or an even surface. As an extra precaution, you may lock the position with strapping across the cross unit.
4. Cut the power supply.
5. Disconnect the chain¹ from the bracket at the upper end of the chain guard, and pull out the chain upwards together with the counterweight.
6. Measure how much of the chain hangs out of the drive housing.
7. Remove the spindle limit switch. Be careful not to change the position of the axle. (Fix it possibly with tape.)
8. Remove the tool bracket/rotation unit from the inner profile.
9. Lift the inner profile and secure it in the lifted position with strapping.
10. Remove the cush drive from the chain by pulling the pin from the chain bracket.
11. Connect the power supply.
12. Feed the chain out at the top by the drive housing.
13. Measure the length of the chain to make sure the new chain has the correct length.
14. Check the condition of the chain sprocket. The teeth must not be worn. (A damaged chain sprocket requires service.)
15. Fit the new chain at the drive housing. Feed the chain down until the same length of chain hangs out as before.
16. Cut the power supply.
17. Make sure the chain is not twisted or has formed a loop inside the pillar unit (a flashlight may be needed for this).
18. Fit the cush drive using a new pin (75/150/250 kg) / new end links (400/650 kg).
19. Fit the tool bracket/rotation unit to the inner profile.
20. Fit the counterweight on the chain, and feed the chain and counterweight into the chain guard.
21. Fit the chain to the top end of the chain guard.
22. Fit the spindle limit switch.
23. Connect the power supply.
24. Remove strapping and support.
25. Drive slowly to the end positions, and measure how much of the inner profile that sticks out at the two positions. Compare with the initial values. The end positions may not be reached mechanically! (If the end positions are not in their correct positions, the spindle limit switch may have to be adjusted, see separate instruction.)
26. Check the function of the slack chain switch by unloading the inner profile on an even, solid surface and carefully driving the lifter downwards. The switch must then stop the downward movement.

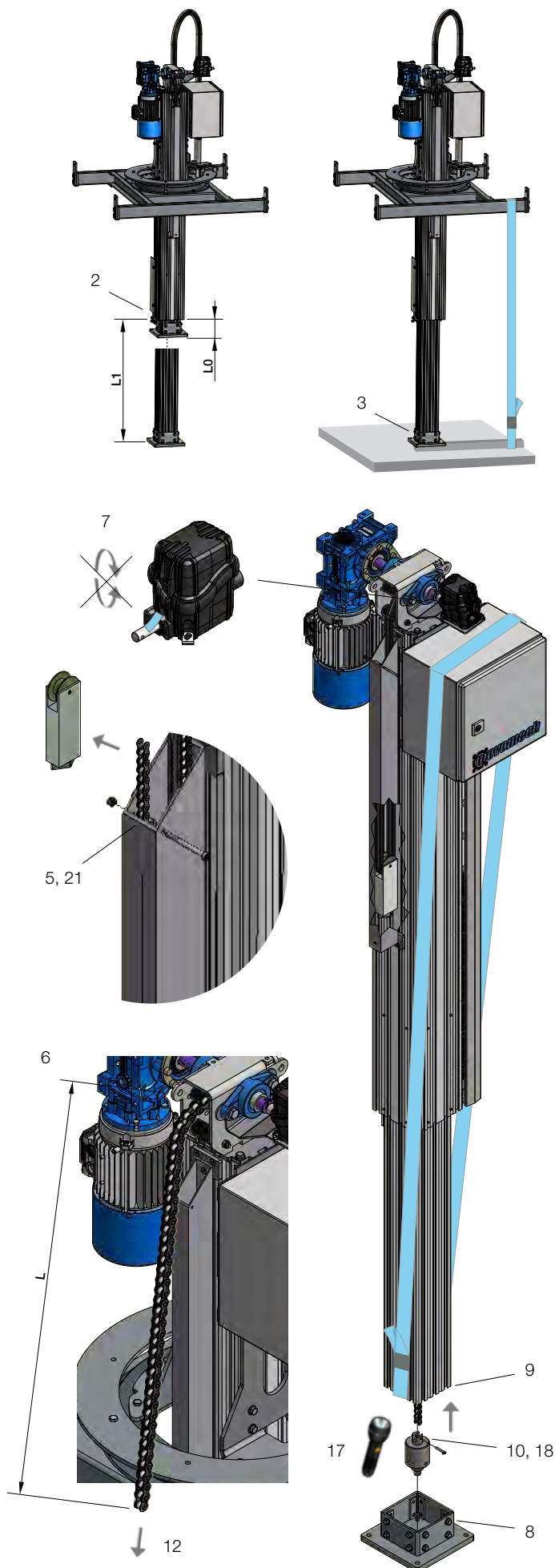

¹ Two chains in the versions 400 kg and 650 kg.

9.5 Adjustment of spindle limit switch

In case of replacing the chain, or such, the setting of the spindle limit position may be affected, which not only changes the upper and lower end limits and the useful length of stroke, but also runs the risk of the Mechlift Pro striking the stroke limit mechanically (Z0 & Z7).

1. Run Mechlift Pro to an upper stop position Z2 where 60 mm of the inner profile sticks out from the outer profile (distance to the upper edge of the tool bracket/rotation unit).
2. Turn screw 2 anti-clockwise until the upper lug strikes the switch (a clicking sound is heard). The lug must strike the switch from the left side.
3. Lower the inner profile approx. 300 mm to Z3. Run it up at full speed, and check if it stops at the upper limit position Z1 > 30 mm from the outer profile. (Please note that Z1 < Z2 due to the slowing down.)

If the upper limit position is Z1 < 30 mm, then repeat step 3 and turn the screw further anti-clockwise until Z1 > 30 mm.

NOTE: on Mechlift Pro 400/650 kg, the lifting movement may be stopped by an end limit switch if the inner profile is lifted too far up. If this happens, then reset the limit switch by activating and then resetting the emergency stop.

4. Starting at Z1, lower the inner profile to the lower stop position Z5, 60 mm before reaching the maximum stroke length SL.

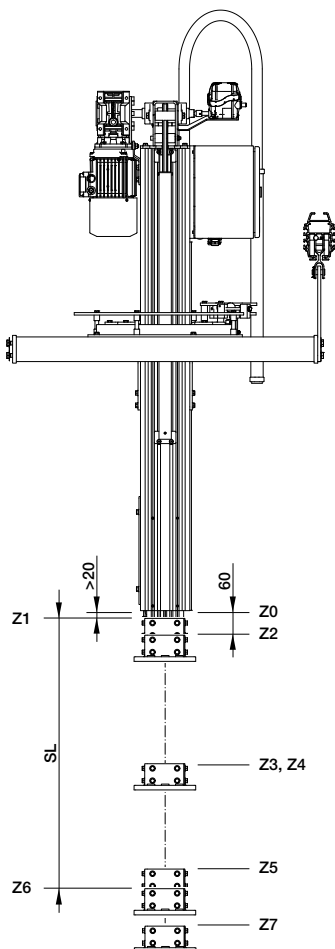

Position	Designation
Z0	Upper mechanical end position (must not be reached)
Z1	Upper end limit
Z2	Upper stop position
Z3	Upper test position
Z4	Lower test position
Z5	Lower stop position
Z6	Lower end limit
Z7	Lower mechanical end position (must not be reached)

(The stroke length SL has some excess capacity; the inner profile must not be lowered all the way to the mechanical end position Z7)

5. Turn screw 1 clockwise until the lower lug strikes the switch. The lug must strike the switch from the right side.
6. Lower the inner profile approx. 300 mm to Z4. Run it down at full speed, and check if it stops at the lower limit position Z6 and check that the stroke length is correct.
7. Repeat step 6 and adjust the screw counter-clockwise if the stroke length is too long or too short, until the stroke length is correct.



9.6 Replacement of sliding blocks

If Mechlif Pro feels unstable and there is a noticeable gap between the pillar profiles, the sliding blocks may need to be replaced.

1. Lower the inner profile 500 mm below the upper end position.
2. Cut the power supply.
3. Unscrew the screws that fix the sliding blocks to the outer profile.
4. Use the removal tool to pull out the sliding blocks.
5. Press in the new slide blocks with the removal tool. When the cut-out in the tool is level with the lower edge of the profile, the upper sliding block is in the correct position.
6. Fix the sliding blocks in position with the screws.
7. Make sure that the pillar unit is stable and without too much play. There must be a minimal play to ensure a smooth and even lifting movement.
8. Connect the power supply.
9. Test the function by running the lifter up and down. Test full speed and slow speed.

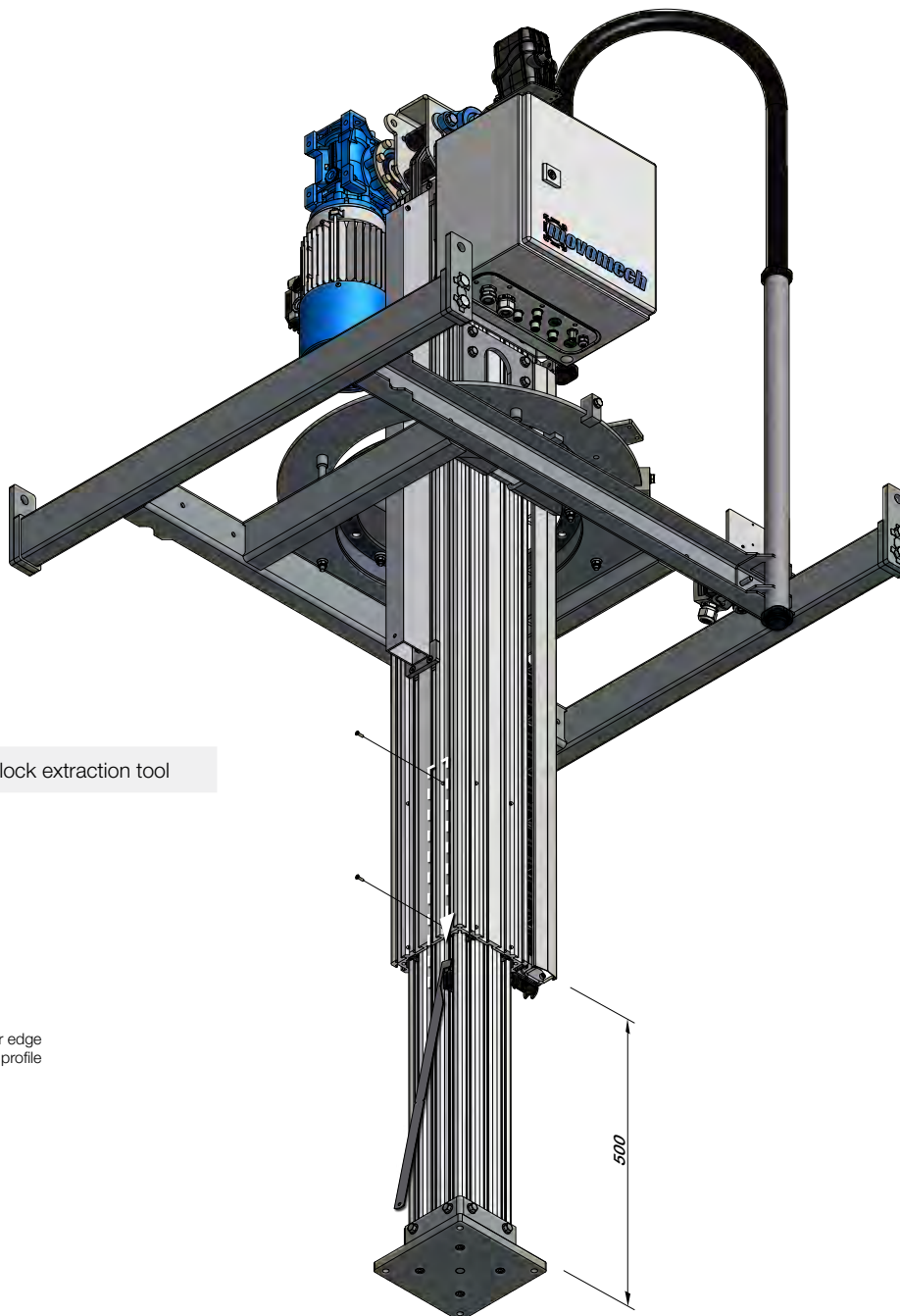

742264 Sliding block extraction tool

Lower edge
outer profile

500

9.7 Troubleshooting

Type of problem	Probable cause	Action
No hoisting motion up/down	Emergency stop is activated.	Check whether emergency stop for some reason has been activated, if no risk what so ever occurs when resetting the stop. Reset emergency stop.
	The hoist is exposed to mechanical obstacle.	Check whether some part of the lifter or tool including any object, are stuck in other equipment. Remove mechanical obstacle.
	Power failure.	Check whether there is a power supply failure, some procedure may be performed by authorized maintenance staff. Reset the power supply.
	Defective control unit.	Check whether the lifter has power, inspect the control unit, some procedure may be performed by authorized maintenance staff. Repair control unit.
	Defective equipment that serve as condition.	Check whether external equipment serving as conditions are defect. Repair equipment.
No hoisting motion down	Slack chain switch is activated.	Check whether some part of the lifter or tool including any object is unloading on any equipment/interior. Free lifter.
Incorrect operating range	Equipment serving as horizontal working range limit is out of position.	Check whether the rotation limits is out of position. Reset to correct position.
	Equipment serving as vertical working range limit is out of position.	Check whether the limit switch unit is damaged. Repair the limit switch unit.
Irregular or jerky hoisting motion up/down	The hoist is exposed to mechanical obstacle.	Check whether some part of the lifter or tool including any object is stuck to any equipment/interior. Remove mechanical obstacle.
	Chain wheel and roller chain are worn out.	Change both chain wheel and roller chain.
Irregular or jerky hoisting motion down	Slack chain switch is misadjusted.	Check whether the slack chain switch is loose, is adjusted to far out from or to near to the roller chain. Adjust the slack chain switch.

9.8 Trip history and inverter status

We recommend that you first find the cause of the fault before clearing it. When a fault occurs, the inverter stores important performance data at the moment of the fault.

To access the data, use the monitor function (dxxx) and select d081 details about the present fault. The previous 5 faults are stored in d082 to d086. Each error shifts d081-d085 to d082-d086, and writes the new error to d081.

The following monitor menu map shows how to access the error codes. When fault(s) exist, you can review their details by first selecting the proper function: d081 is the most recent, and d086 is the oldest.

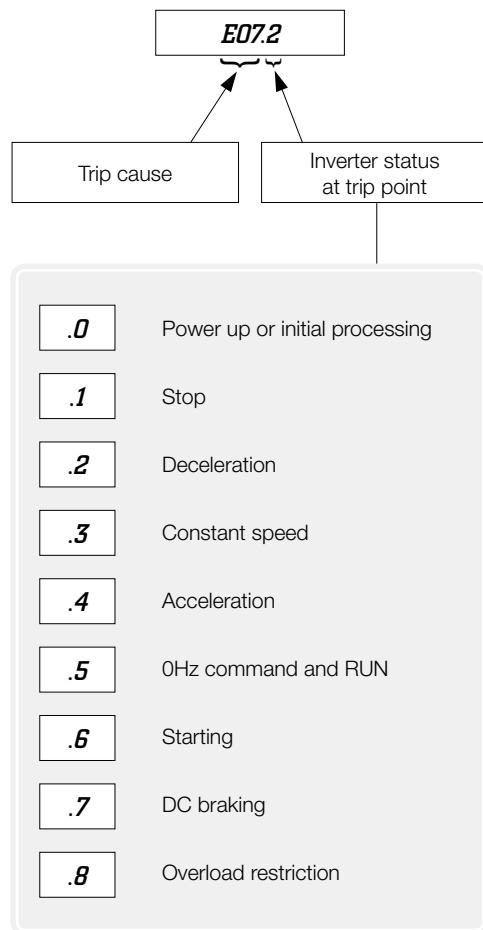
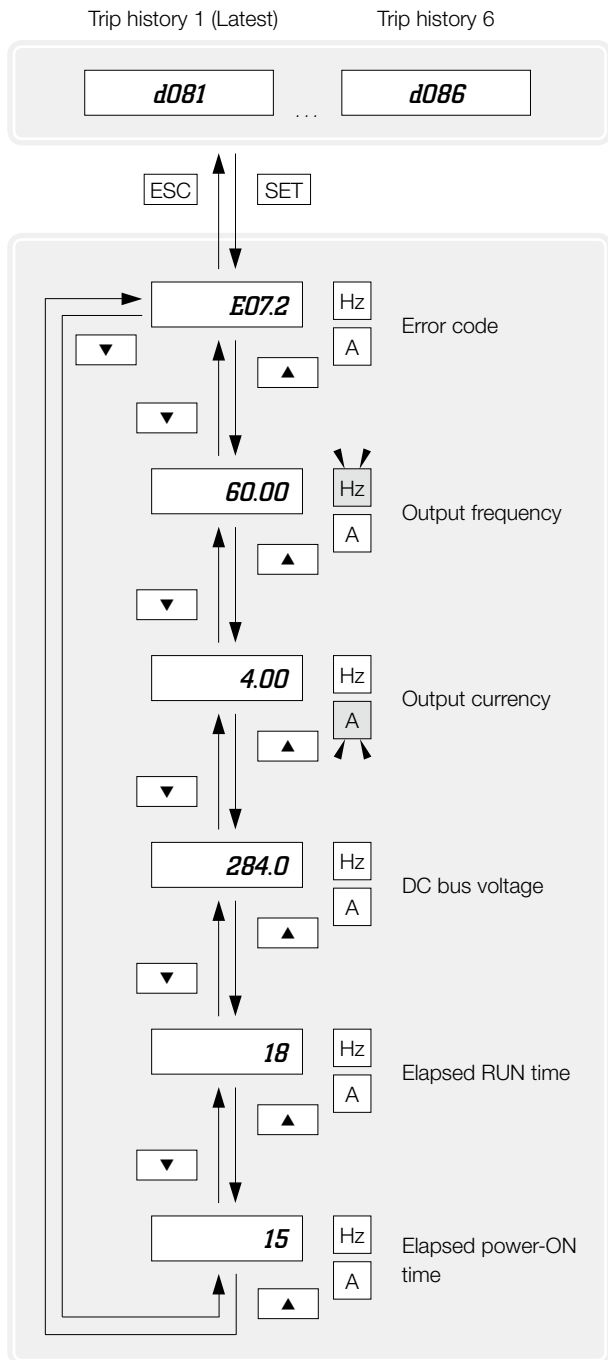

- Note: Indicated inverter status could be different from actual inverter behaviour.
E.g. When PID operation or frequency given by analogue signal, although it seems constant speed, acceleration and deceleration could be repeated in very short cycle.

Error code	Name	Cause(s)
E01	Over-current event while at constant speed	The inverter output was short-circuited, or the motor shaft is locked or has a heavy load. These conditions cause excessive current for the inverter, so the inverter output is turned OFF.
E02	Over-current event during deceleration	The dual-voltage motor is wired incorrectly.
E03	Over-current event during acceleration	
E04	Over-current event during other conditions	
E05	Motor overload protection	When a motor overload is detected by the electronic thermal function, the inverter trips and turns OFF its output. Check that the thermal model is properly set in parameter b0 12, b0 13, b9 10, b9 11 and b9 12. Check if the application can accept softer acceleration rates to minimize peak currents F002/F202/A092/A292). Check if motor parameters are not correctly set (H020 to H034 or H005), depending in motor control method (A044/A244).
E06	Braking resistor overload protection	When the BRD operation rate exceeds the setting of "b090", this protective function shuts off the inverter output and displays the error code.
E07	Over-voltage protection	When the DC bus voltage exceeds a threshold, due to regenerative energy from the motor.
E08	EEPROM error	When the built-in EEPROM memory has problems due to noise or excessive temperature, the inverter trips and turns OFF its output to the motor.
E09	Under-voltage error	A decrease of internal DC bus voltage below a threshold results in a control circuit fault. This condition can also generate excessive motor heat or cause low torque. The inverter trips and turns OFF its output.
E10	Current detection error	If an error occurs in the internal current detection system, the inverter will shut off its output and display the error code.
E11	CPU error	A malfunction in the built-in CPU has occurred, so the inverter trips and turns OFF its output to the motor.
E12	External trip	A signal on an intelligent input terminal configured as EXT has occurred. The inverter trips and turns OFF the output to the motor.
E13	USP	When the "Unattended start protection" (USP) is enabled, an error occurred when power is applied while a run signal is present. The inverter trips and does not go into "Run mode" until the error is cleared.
E14	Ground fault	The inverter is protected by the detection of ground faults between the inverter output and the motor upon during powerup tests. This feature protects the inverter, and does not protect humans.
E15	Input over-voltage	The inverter tests for input over-voltage after the inverter has been in "Stop mode" for 100 seconds. If an over-voltage condition exists, the inverter enters a fault state. After the fault is cleared, the inverter can enter "Run mode" again.
E21	Inverter thermal trip	When the inverter internal temperature is above the threshold, the thermal sensor in the inverter module detects the excessive temperature of the power devices and trips, turning the inverter output OFF.
E22	CPU communication error	When communication between two CPU fails, inverter trips and displays the error code.
E25	Main circuit error (*3)	The inverter will trip if the power supply establishment is not recognized because of a malfunction due to noise or damage to the main circuit element.
E30	Driver error	If instantaneous overcurrent occurs the Inverter will shut off IGBT's output to protect the main circuit element. After tripping due this protective function the inverter cannot retry the operation.
E35	Thermistor	When a thermistor is connected to terminals [5] and [L] and the inverter has sensed the temperature is too high, the inverter trips and turns OFF the output.
E36	Braking error	When "D 1" has been specified for the "Brake control selection" (b 120), the inverter will trip if it cannot receive the braking confirmation signal within the "Brake wait time for confirmation" (b 124) after the output of the brake release signal. Or when the output current doesn't reach the brake release current (b 126) during the brake wait time for release (b 121).
E37	Safe stop	Safe stop signal is given.*
E38	Low-speed overload protection	If overload occurs during the motor operation at a very low speed, the inverter will detect the overload and shut off the inverter output.
E40	Operator connection	When the connection between inverter and operator keypad failed, inverter trips and displays the error code.
E41	Modbus communication error	When "trip" is selected (C076=00) as a behavior in case of communication error, inverter trips when timeout happens.
E43	Drive programming invalid instruction	The program stored in inverter memory has been destroyed, or the PRG terminal was turned on without a program downloaded to the inverter.
E44	Drive programming nesting count error	Subroutines, if-statement, or for-next loop are nested in more than eight layers
E45	Drive programming instruction error	Inverter found the command which cannot be executed.
E50-E59	Drive programming user trip (0 to 9)	When user-defined trip happens, inverter trips and displays the error code.
E51	Top limit switch (only 400/650 kg)	Check that the rotary limit switch is working and that it is correctly adjusted. Reset by activating and then resetting the emergency stop. It is now only possible to drive the manipulator downwards until the top limit switch is unaffected.
E60-E69	Option errors (error in connected option board, the meanings change upon the connected option).	These errors are reserved for the option board. Each option board can show the errors for a different meaning. To check the specific meaning, please refer to the corresponding option board user manual and documentation.
E80	Encoder disconnection	If the encoder wiring is disconnected, an encoder connection error is detected, the encoder fails, or an encoder that does not support line driver output is used, the inverter will shut off its output and display the error code shown on the right.
E81	Excessive speed	If the motor speed rises to "maximum frequency (A004) x overspeed error detection level (P026)" or more, the inverter will shut off its output and display the error code shown on the right.
E83	Positioning range error	If current position exceeds the position range specification (P072-P073), the inverter will shut off its output and display the error code.

* E37.X only can be reset by digital input (18: RS).

10. EC certificate

CE EC declaration of conformity of the machinery

TRANSLATION
(according to 2006/42/EC, annex 2A)

Manufacturer

Roni
• 8001 Tower Point Drive • Charlotte, NC 28227
• U.S.A. • Toll Free (866) 543-8635
Ph.: (704) 847-2464 • Fax: (866) 543-9532
• Email: info@roni.com
• Web Site: http://www.roni.com

Representative for documentation
Representative for documentation

hereby declares that the machinery

Designation
Electric Mechlif Pro

Designation

Machine type
Lifting unit

Version
75, 150, 150-3, 250, 250-3, 400, 650

complies to all applicable regulations
in

Machinery Directive 2006/42/EC

EMC Directive 2004/108/EC

and that standards and/or technical specifications as described below are applied.

Machinery Directive
SS-EN-ISO 12100:2010

EMC Directive

Low Voltage Directive
IEC 60204-32
IEC 60204-1

Place: Kristianstad

Date: 2015-06-01



11. Revisions

Revision list

Edition	#	Designation	Pages
2015-06-01	0	First edition	-