

Mechline Pro 50

Original instructions 2016-12-01

EN
CE



Table of contents

| | | |
|-----|---|----|
| 1. | Safety | 4 |
| 2. | Technical data..... | 7 |
| 2.1 | Overview..... | 8 |
| 3. | Sub-assemblies | 9 |
| 3.1 | Base models..... | 9 |
| 4. | Pneumatic configurations..... | 13 |
| 4.1 | Pneumatics: 2-weight | 14 |
| 4.2 | Pneumatics: 2-weight with slow speed function | 16 |
| 4.3 | Pneumatics: 3-weight | 18 |
| 4.4 | Pneumatics: 3-weight with slow speed function | 20 |
| 4.5 | Pneumatics: direct control..... | 22 |
| 4.6 | Pneumatics: direct control with load guard..... | 24 |
| 5. | Options..... | 26 |
| 5.1 | Pneumatic load limiting kit..... | 26 |
| 5.2 | Air preparation unit..... | 28 |
| 6. | Control units | 29 |
| 7. | Installation and commissioning..... | 30 |
| 7.1 | Initial adjustment: 2-weight..... | 30 |
| 7.2 | Initial adjustment: 3-weight..... | 30 |
| 7.3 | Initial adjustment: slow speed function | 30 |
| 7.4 | Initial adjustment: direct control with speed handle..... | 31 |
| 7.5 | Initial adjustment: load guard..... | 31 |
| 7.6 | Initial adjustment: load limiting kit | 32 |
| 7.7 | Mounting on Mechcrane Pro | 32 |
| 8. | User instructions..... | 33 |
| 9. | Service, maintenance & running | 34 |
| 9.1 | Recommended spare parts / wear parts | 35 |
| 9.2 | Service record — Mechline Pro 50 | 36 |
| 9.3 | Replacement of wire | 37 |
| 9.4 | Shortening of build height BH..... | 38 |
| 9.5 | Testing anti-jump function | 39 |
| 9.6 | Replacement of front pulley (complete)..... | 40 |
| 9.7 | Adjustment of pressure guard 739553 | 40 |
| 9.8 | Troubleshooting..... | 41 |
| 10. | EC certificate | 42 |
| 11. | Revision list..... | 43 |

Although the greatest care was taken regarding the information in this catalogue, we assume no responsibility for any errors. We reserve the right to make changes. The illustrations in the catalogue represent the described products, but the delivered goods may differ in some respects from the illustrations. The right is reserved to make changes in design and dimensions compared with the information in the catalogue in order not to prevent development of designs, material and manufacturing methods.

The customer is reminded that in the purchase of Movomech's products for application on the job or elsewhere, there is supplementary, current information that could not be included in the catalogue in terms of recommendations on each product's suitability regarding different combinations of Movomech's comprehensive product line. All relevant information must be provided to the persons who are responsible for the application of the product.

1. Safety

Movomech's equipment is manufactured in accordance with the latest technological advances, and according to the latest applicable European standards and directions. The aim of this documentation is to provide the user with practical instructions for safe operation and simple maintenance of the equipment.

Anyone who deals with the installation of the equipment (including related equipment), operational procedure, use, maintenance, and/or repair functions must have read and understood:

- the instruction manual,
- the safety regulations, and
- the safety instructions for each individual section.

In order to avoid misuse and to ensure the reliable operation of the products, we recommend that the instruction manual is always available to the user/operator.

Intended usage

The equipment is intended exclusively for transportation, lifting and lowering of load. Any other use, including the towing of a load and the transportation of passengers, is prohibited (see below for more examples). Movomech does not accept responsibility for damage caused by such use. All risks are the sole responsibility of the user.

The equipment may only be used in perfect technical condition by trained staff, and in accordance with current safety and work protection regulations. Furthermore, the user must observe operational and maintenance conditions contained in the instruction manual. Severe personal injury and damage to equipment can be caused by:

- removal of covers and casings,
- non-professional installation of equipment,
- incorrect usage, or
- insufficient maintenance.

Prohibited usage

Certain types of activities and operations are prohibited, as in specific circumstances they can cause personal injury as well as permanent damage to the construction. For example:

- It is prohibited to convey passengers using the equipment.
- Never transport suspended loads above anyone's head.
- Never drop a suspended load, and make sure it is lifted in a straight line.
- Never loosen secured or fastened loads by using the equipment.
- Do not overload.
- Do not leave a suspended load unattended.

General safety aspects

The instruction manual should always be kept within easy reach of the equipment. It contains important safety information and sections that relate to guidelines, norms, and regulations. Failure to follow the safety regulations in this instruction manual may result in personal injury or death.

In addition to the instruction manual, generally applicable regulations and rules must be followed and adhered to in order to avoid accidents and protect the environment. This also applies to regulations relating to the handling of products dangerous to the environment and the use of personal safety equipment.

As regards all work associated directly or indirectly with the equipment, the user must follow and adhere to all the above regulations as well as current work protection and safety regulations. In spite of this, a life-threatening risk still prevails in cases where the equipment is used and operated by non-trained or non-instructed staff in a non-professional or non-intended way.

The user should supplement the instruction manual with instructions that consider the nature of the operation, e.g. company organisation, work procedures, and number of staff.

The members of staff who are assigned to work with the equipment must have read the instruction manual prior to undertaking any work, and he/she should pay particular attention to the chapters containing safety instructions. It is too late once work has commenced. This applies in particular to members of staff who are working with the equipment on a temporary basis, e.g. for maintenance purposes.

When convenient, the staff should be tested on their knowledge of the manual's contents that relate to safety and accident awareness.

The user is responsible for ensuring that the equipment is used only when it is in perfect condition and that all applicable and relevant safety regulations and requirements are followed.

The equipment should be taken out of operation immediately if functional damage or defects are discovered.

Personal safety equipment should be used as and when necessary, or when required by regulations.

Safety and warning devices, such as signs, stickers and labels must not be removed or made illegible.

All safety and warning devices on or adjacent to the equipment should be complete and maintained in a legible/functional condition.

All changes, extensions or reconstruction that may affect safety are forbidden without written permission from Movomech. This also applies to assembly and adjustment of safety equipment and welding of structural parts.

Spare parts must comply with Movomech's stated technical requirements. This compliance is guaranteed when original spare parts are used. The intervals prescribed or stated in the instruction manual for regular testing/inspection must be adhered to!

Staff selection and qualifications

Reliable staff must carry out work with/on the equipment. Regulations that apply to under-age persons must be followed.

The user is responsible for supplying necessary training and instructions to those that he/she employs, including professionals and/or apprentices.

It is recommended that the user draws up instructions and guidelines relating to the causes of errors, communicates these to the relevant staff, and posts directions on appropriate and clearly visible places.

It is recommended that the user makes sure that the knowledge of the staff is adequate as regards the following points, prior to the operation of the construction:

- knowledge of the contents of the instruction manual,
- knowledge of the safety and user regulations contained therein,
- and knowledge of applicable work protection regulations.

Only trained and instructed staff should be permitted to work with the equipment. Parameters relating to use, maintenance, and installation should be clarified.

Safety instructions for usage

The only persons allowed to work on the electrical equipment are competent staff members who work in accordance with regulations and standards for high-voltage equipment.

No persons under the influence of drugs, alcohol or medication which affects their ability to react, are allowed to use, maintain, or repair the construction.

All stated actions and instructions relating to work protection and issues relating to general safety and protection of workers that should be carried out or studied prior to, during or following operation must be followed to the letter. Failure to do so may result in fatal accidents.

The equipment should be stopped or taken out of operation at the time of detection of faults relating to work protection and operational accessibility.

Safety equipment must not be deactivated, altered or used in a way that conflicts with applicable regulations.

Appropriate actions must be taken to ensure safe operation and functional conditions for the user.

The equipment should only be used when all protective and safety equipment, such as detachable guards and emergency stop devices, are in place and in working order.

Any type of modification and alteration of the equipment is prohibited. However, this does not apply to lesser changes that do not affect the strength, operational safety or work protection, or to actions which promote an increased level of safety.

The fundamental responsibility for these changes lies with the user. If in doubt, contact Movomech for written approval of the actions prior to implementation.

The equipment should be stopped and locked immediately when functional faults occur. Faults should be corrected immediately!

Following an "emergency stop" the user has to wait for the cause of the disruption to be repaired and for an assurance that there is no further danger before he/she reconnects the equipment and resumes operation.

The equipment should be disconnected immediately in the following cases:

- when electrical equipment, cables and/or insulation material is damaged, or
- when work protection equipment is damaged.

Specific local circumstances or applications may lead to situations that were unknown at the time of writing this document. In such cases, the user must ensure safe operation and disconnect the equipment until measures to maintain safe operation have been carried out in conjunction with Movomech or other authorised party.

Ensure that no one can become injured when they use the equipment prior to connecting/activating the equipment.

If the user notices the presence of persons who may become injured during operation, the operation should be discontinued immediately and must not be resumed until these persons have left the dangerous area.

The user must make sure that the equipment is in a perfect and operationally safe condition prior to all operations using the equipment.

The user should carry out all prescribed safety measures and make sure that automated procedures are completed when the equipment is disconnected (e.g. when there are deficiencies as regards operational and personal safety, an emergency situation exists, repair or maintenance is being carried out, damage is noticed or at the completion of work).

Work with the equipment is only allowed when the operator has been instructed to do so by his superior, and if the operator has knowledge of the equipment and its function.



Note in particular:

- Do not use the lifting unit when any kind of damage on the lifting unit, lifting wire, swivel or its gripping tool.
- Check that the shackle is properly locked (with cotter) before use.
- Never lift a heavier load than allowed, total load includes total load of gripping tool and handled object.
- Mechline Pro is equipped with an anti-jump function, intended to prevent unwanted lifting, for example, if a load is dropped or if an internal pressure is accumulated in the lifter. It is not intended to be used as an end stop or travel limit.
- The lifter is not intended for use with gripping tool in the form of hook or similar.
- Ensure that the handled object and/or gripper tool are not locked or risk being trapped during the movement / lifting motion (A).
- The operator may not be in close proximity to the wire while operating the lifter (B).
- The lifting unit should always be positioned vertically above the handled object during the lifting operation (C).

Prohibited use

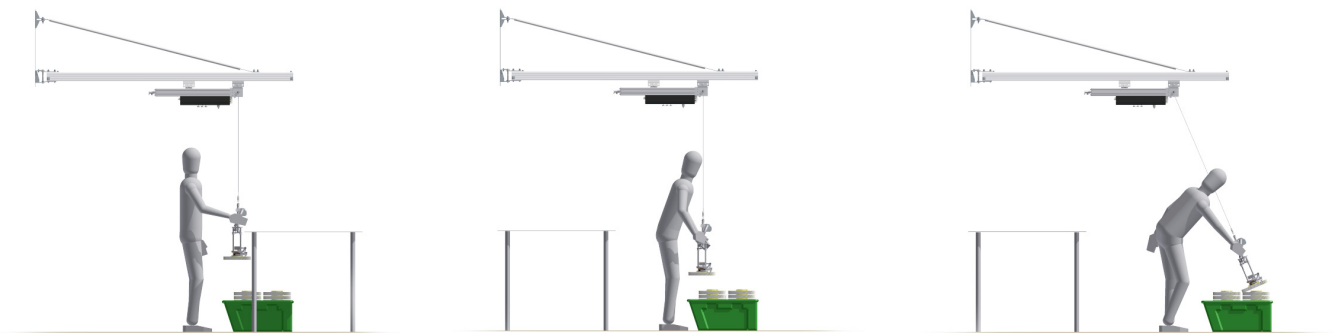

A Risk of entrapment of object

B Operator close to lifting wire

C Lifting unit not above object

2. Technical data

Mechline Pro is an easily maneuvered pneumatic line balancer for loads up to 50 kg. The Mechline lifting wire is extremely durable and can be used for up to 300,000 work cycles.*

The swivel is advantageously integrated with a pneumatic gripper and its controls. Even a simple mechanical gripper tool allows easy and ergonomic handling.

Mechline Pro is very light-weight and provides a lifting stroke of up to 2 meter. It is preferably installed in a rail system or in a wall- or pillarmounted crane.

Mechline Pro is in its standard version equipped with an adjustable anti-jump function that locks the lifting motion in the event of uncontrolled lifting, for example, if the load is accidentally dropped. This provides a safe working environment for the operator.

Typical applications for Mechline Pro is lifting work at assembly stations within the manufacturing and the automotive industry, as well as material handling at transport and conveyor lines.

With Mechline Pro, the operator can handle the load seemingly weightless; with an integrated control unit for various loads or a separate actuator for the selection of up to three different loads.

A range of pneumatic versions are available:

- **Balanced 2-weight:** handling of one balanced load; with an external actuator the operator selects "Load" or "Without load".
- **Balanced 3-weight:** handling of two balanced loads; with external actuator the operator selects "Load 1", "Load 2", or "Without load".
- **Direct control:** a precise and smooth handling of varying loads with a control unit. A convenient speed handle is available as standard control unit.

Optional extras are load guard, slow speed function and load limiting kit.

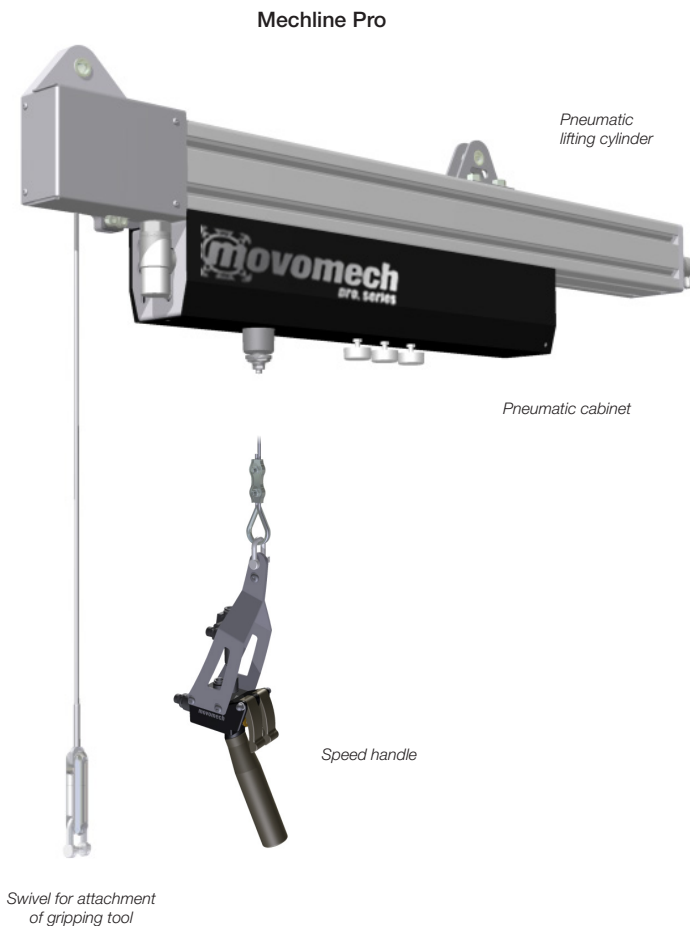

| Technical data | | Mechline Pro 50 |
|-----------------|-------|--------------------|
| Max load | kg | 50 |
| Max moment | Nm | 0 |
| Max tare weight | kg | 15 |
| Stroke SL | mm | 500-2000 |
| Length L | mm | 360+SL/2 |
| Rotation | ° | 0-360 ¹ |
| Lifting speed | m/min | 0-40 |

¹ Unlimited

| Media & Environment | | Mechline Pro 50 |
|---------------------|---------------------------------|--|
| Medium | | air, non-lubricated (0,01 µm) ¹ |
| Max work pressure | bar | 5 ² |
| Air consumption | l _v /m _{SL} | 7,8 (at 5 bar) |
| Work temperature | °C | 5-40 (indoor use) |
| Noise level | dB (A) | <70 |

¹ FRL unit is available as option.

² The lifting unit is prepared for an incoming air pressure of 5 bar unless stated otherwise in the specification.

³ Consumption per meter stroke at max load. Gripping tool not included. The value is indicative and may vary depending on specific customer requirements. See also table below.

| Consumption per full stroke | | 800 | 1200 | 500-2000 |
|-----------------------------|----------------|-----|------|---------------|
| Consumption /cycle | l _n | 6,2 | 9,4 | (SL/1000)*7,8 |

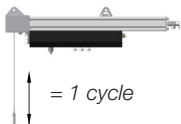

Note:

1 cycle = 1 movement up + down, regardless of the length of stroke and movement combination. Thus, a material handling operation can consist of a combination of several cycles.

The wire must be replaced at least every 300,000 work cycles, or if damaged.

2.1 Overview

2-weight, 3-weight

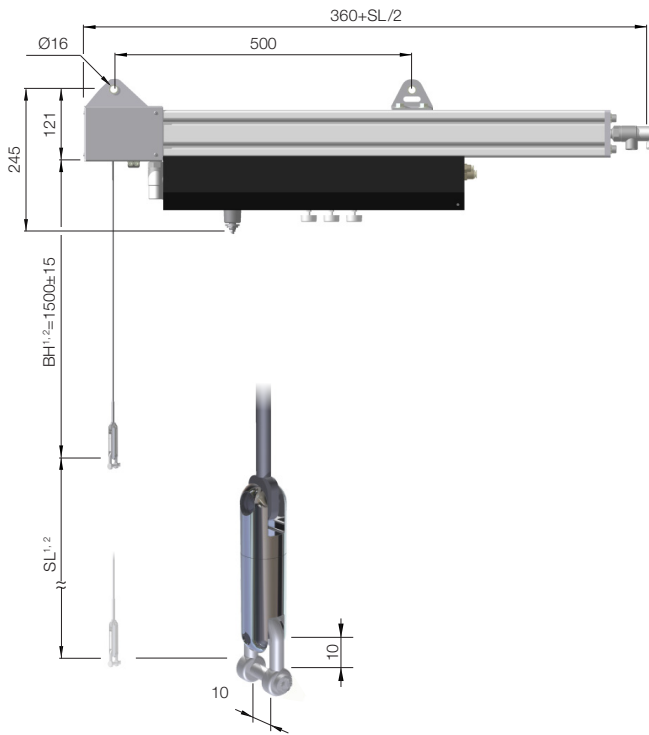

Direct control with speed handle

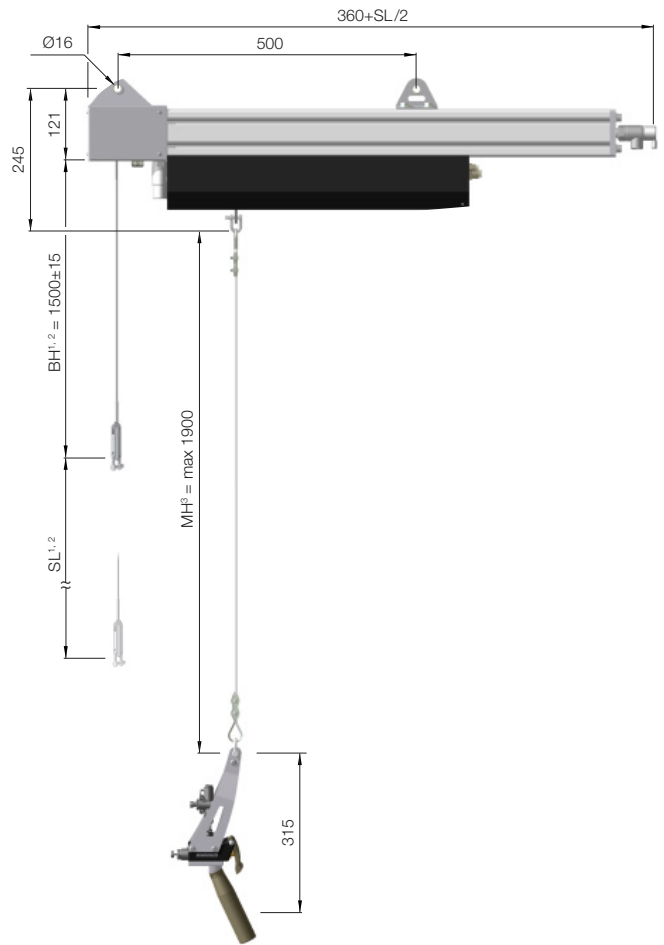

| Base model | | 738860 | 738861 | 738862 |
|------------------------------|----|----------|----------|----------|
| Stroke SL | mm | 800 | 1200 | 500-2000 |
| Length L | mm | 760 | 960 | SL/2+360 |
| Build height BH ¹ | mm | 1500 | 1500 | 1500 |
| Wire length VL ¹ | mm | 2770 | 3170 | SL+1970 |
| Height MH ² | mm | max 1900 | max 1900 | max 1900 |

| Optional height BH | | 739837 | 739838 |
|------------------------------|----|-----------|-----------|
| Build height BH ² | mm | 300-1200 | 1201-2000 |
| Wire length VL ² | mm | SL+BH+470 | SL+BH+470 |

¹ Standard build height BH = 1500 mm

² Option. If standard values are not used, SL and BH are defined in the specification.

³ When applicable. Adjusted on site, delivered with separate thimble and wire joint.

3. Sub-assemblies

3.1 Base models

| 73886x | | Base model Mechline Pro 50 | |
|--------|-------------|--------------------------------|----------|
| # | Article nr. | Designation | Quantity |
| 1 | *1 | Profile MP80C, L=L1 | 1 |
| 2 | 739011 | Rear suspension | 2 |
| 3 | 738858 | Wire with loop, complete | S 1 |
| 4 | 738852 | Piston, complete | 1 |
| 5 | 730116 | MM2x8 t-slot nut double c/c 40 | 2 |
| 6 | 730216 | Screw M6SZ M8x12 | 4 |
| 7 | 738875 | Non-return valve G3/8" | R 2 |
| 8 | 739704 | Swivel | R 1 |
| 9 | 739752 | Front end | 1 |
| 10 | 732504 | Bushing (for LHB trolley) | 2 |
| 11 | 730115 | MM8 t-slot nut single | 2 |
| 12 | 732279 | Screw MC6S M8x40 | 4 |
| 13 | 738890 | Shackle M5 stainless | 1 |
| 14 | 731558 | Straight fitting G3/8"-8 | 1 |
| 15 | 738892 | Washer 5,3x10x1 A4 | 4 |
| 16 | 739774 | Rear end cap | 1 |
| 17 | 730727 | Screw MC6S M8x25 | 4 |
| 18 | 739782 | Cover | 1 |
| 19 | 742386 | O ring | S 1 |
| 20 | 742156 | Shrink tubing 2,4/1,2 | S 0,02 |

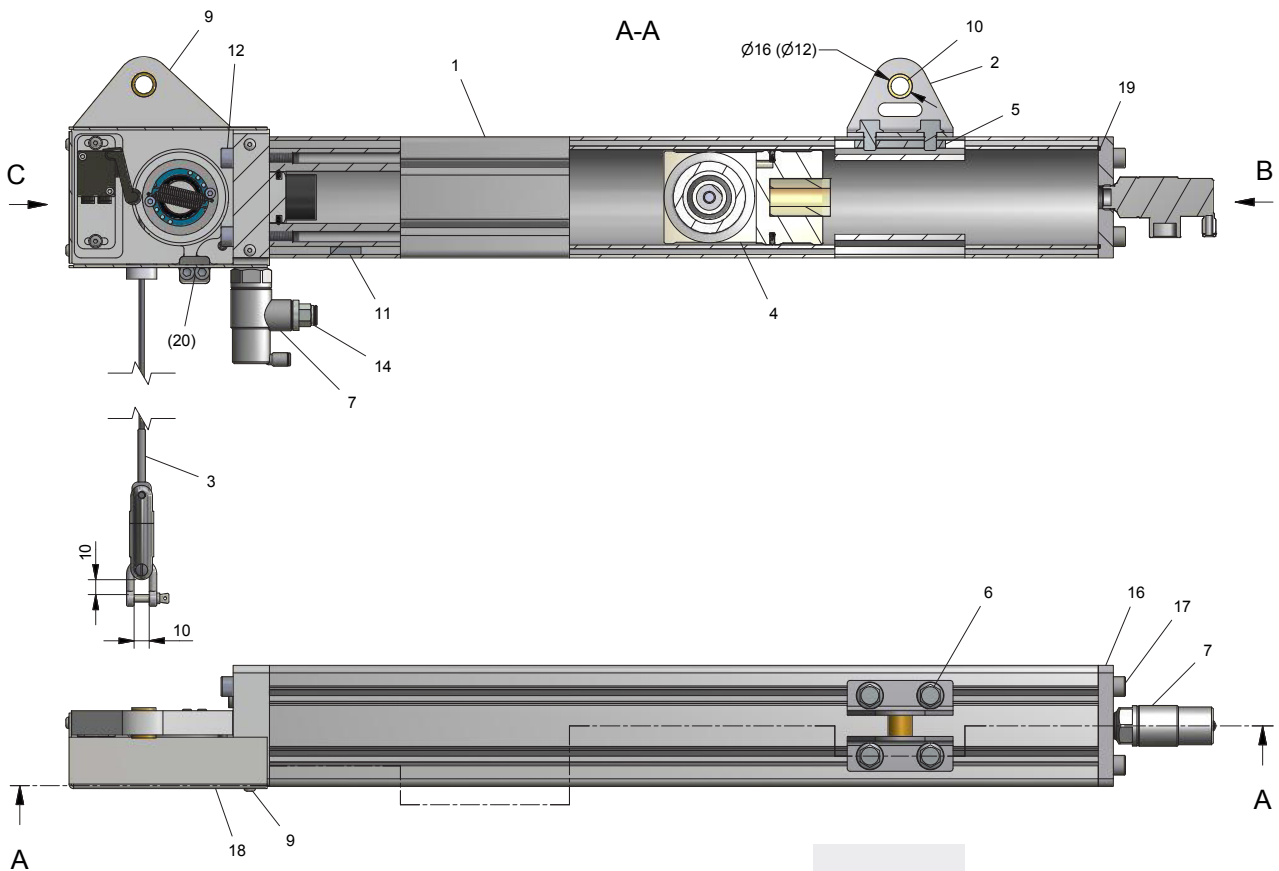
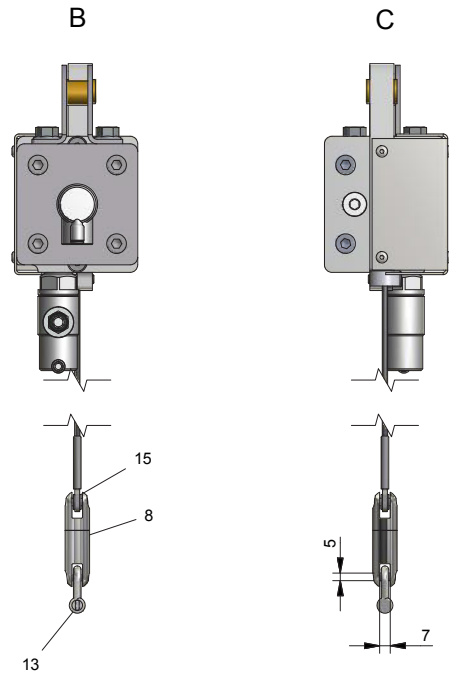

| Base model | 738860 | 738861 | 738862 |
|----------------|--------|--------|----------|
| Stroke SL mm | 800 | 1200 | 500-2000 |
| Article nr. *1 | 739840 | 739841 | 739842 |
| Length L1 mm | 548 | 748 | SL/2+148 |

| 738852 | | Piston, complete | |
|--------|-------------|------------------------|----------|
| # | Article nr. | Designation | Quantity |
| 1 | 739003 | Axis | 1 |
| 2 | 738855 | Shim ring 18x30x0,5 | 4 |
| 3 | 731069 | Screw MC6S M8x45 | 1 |
| 4 | 740611 | Piston | 1 |
| 5 | 740622 | Piston seal | S 1 |
| 6 | 739094 | Rubber damper 25/12x40 | 1 |
| 7 | 739933 | Rear pulley, complete | R 1 |

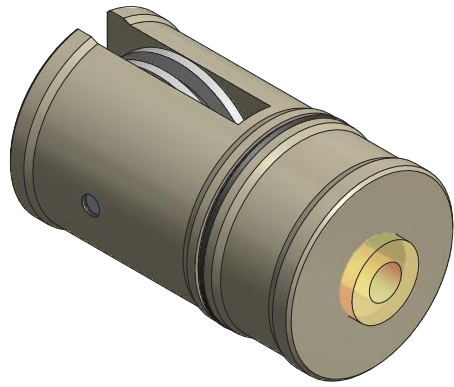

A-A

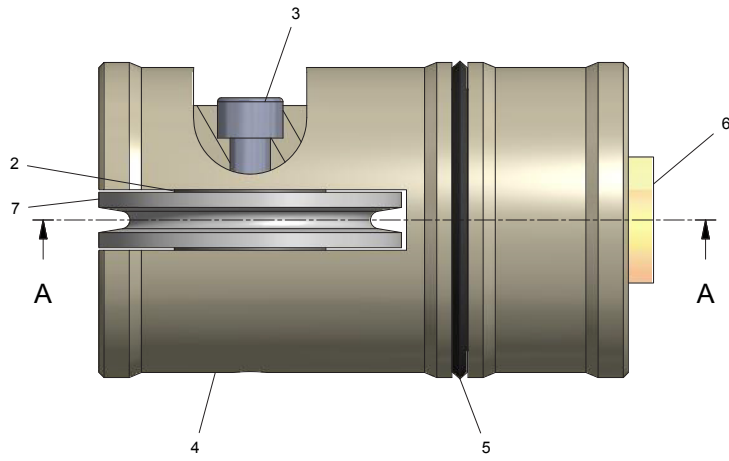
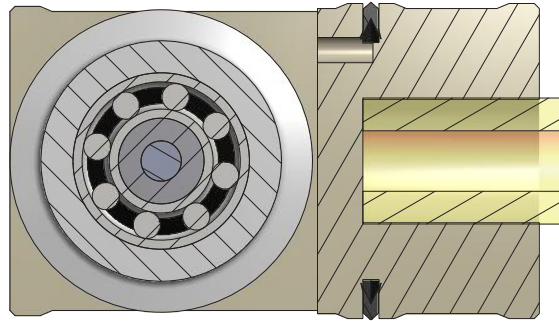

739752 Front end

| # | Article nr. | Designation | Quantity |
|----|-------------|------------------------|----------|
| 1 | 742430 | Pulley housing | 1 |
| 2 | 739005 | Front end cap | 1 |
| 3 | 739783 | Valve bracket | 1 |
| 4 | 739934 | Front pulley, complete | R 1 |
| 5 | 738874 | 3/2 valve NO | R 1 |
| 6 | 742431 | Wire guiding | S 1 |
| 7 | 739018 | Wire lock | 1 |
| 8 | 735578 | Screw MC6S M3x20 | 2 |
| 9 | 738232 | O ring | S 1 |
| 10 | 738863 | Screw K6S M4x6 A2 | 4 |
| 11 | 730266 | Screw MC6S M6x16 | 3 |
| 12 | 730276 | Washer BRB 4.3x8x0.8 | 2 |
| 13 | 730449 | Rubber damper | S 1 |
| 14 | 739072 | Screw MP6SS M6x12 | 1 |
| 15 | 739234 | Plug G1/8"-P10 | 1 |
| 16 | 731049 | O ring | S 1 |
| 17 | 734554 | Screw MF6S M6x35 | 2 |
| 18 | 739784 | Washer SRKB 7x22x1,5 | 1 |
| 19 | 739946 | Rubber clamp | 1 |
| 20 | 735557 | Screw K6S M4x10 A2 | 2 |
| 21 | 740538 | Sealing | S 1 |
| 22 | 740628 | Screw MC6S M5x8 A2 | 1 |

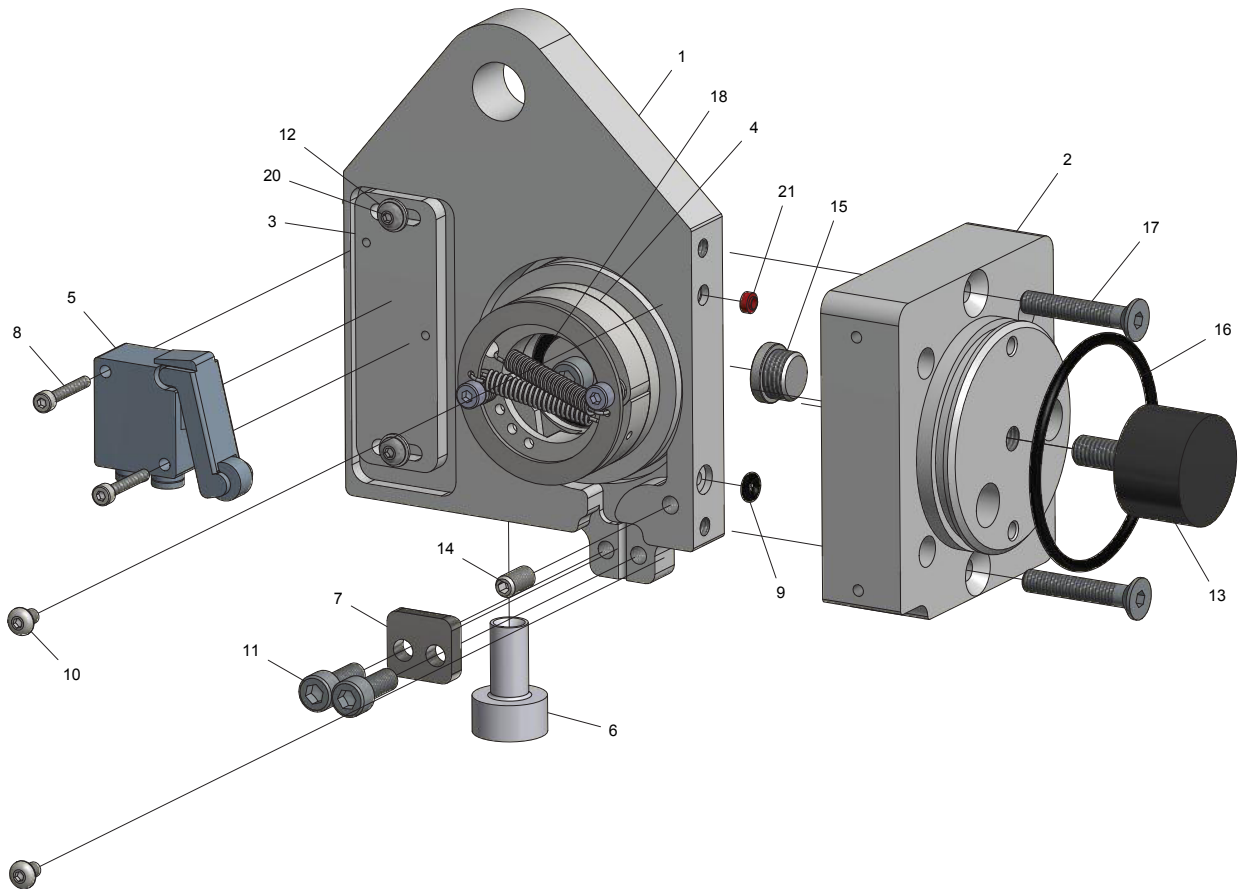
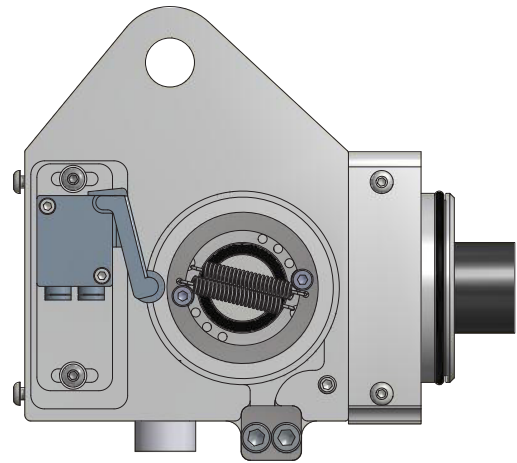
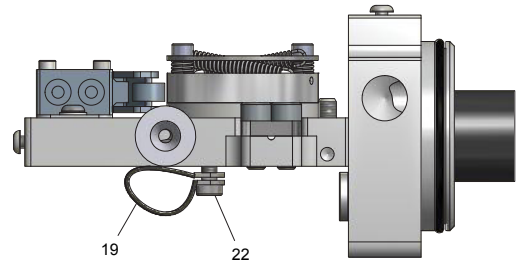

4. Pneumatic configurations

Overview

- 4.1 Pneumatics: 2-weight 14
- 4.2 Pneumatics: 2-weight with slow speed function 16
- 4.3 Pneumatics: 3-weight 18
- 4.4 Pneumatics: 3-weight with slow speed function 20
- 4.5 Pneumatics: direct control 22
- 4.6 Pneumatics: direct control with load guard 24

4.1 Pneumatics: 2-weight

| # | Article nr. | Designation | Quantity |
|-----------------|-------------|----------------------------|----------|
| 738880 2-weight | | | |
| 1 | 735350 | Air preparation unit (FRL) | (1)* |
| 2 | 738874 | 3/2 valve NO | (1)** |
| 3 | 738875 | Non-return valve G3/8" | (1)** |
| 4 | 738876 | 3/2 valve NC | R 1 |
| 5 | 739772 | Attachment plate | 1 |
| 6 | 733374 | 5/2 valve, monostable | R 1 |
| 7 | 732669 | OR gate | R 1 |
| 8 | 731583 | Precision regulator | R 1 |
| 9 | 739553 | Pressure guard | R 1 |
| 10 | 738124 | Precision regulator | R 2 |
| 11 | 738125 | 3/2 valve monostable | R 1 |
| 12 | 732838 | Spiral hose, double 6/4 | 1 |
| 13 | 731806 | Washer 8,4x26x5 | 4 |
| 14 | 739776 | Bracket | 1 |
| 15 | 739233 | Plug G1/8" | 1 |
| 16 | 739773 | Cover | 1 |
| 17 | 740637 | Protection plate | 1 |
| 18 | 739270 | Push-in connector 4-4 | 1 |
| 19 | 739271 | Push-in connector 6-6 | 2 |
| 20 | 739272 | Push-in connector 8-8 | 1 |
| 21 | 738864 | Distance plate | 1 |
| 22 | 740533 | Rubber cover plate Ø14 | 1 |
| 23 | 741413 | Rubber cover plate Ø31,8 | 1 |
| 24 | 730218 | Screw M6SZ M8x16 | 4 |

* Option ** Included in 739752 Front end

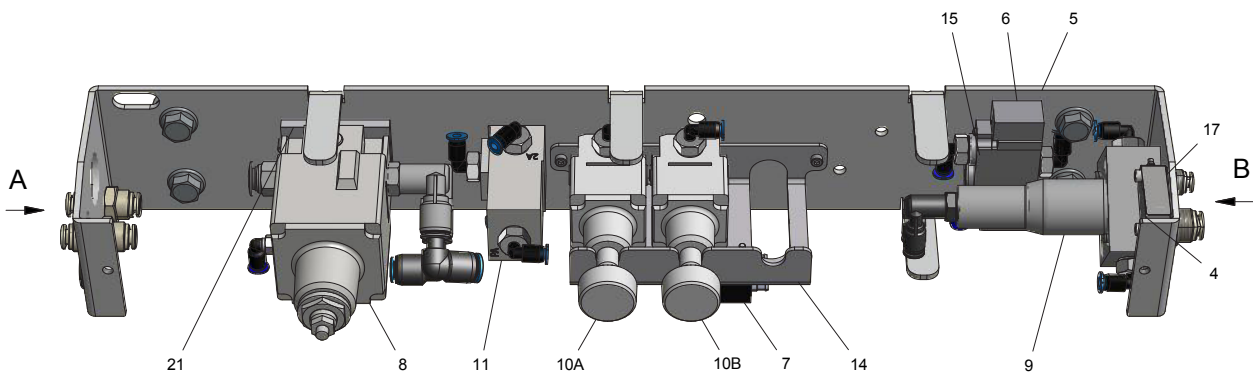
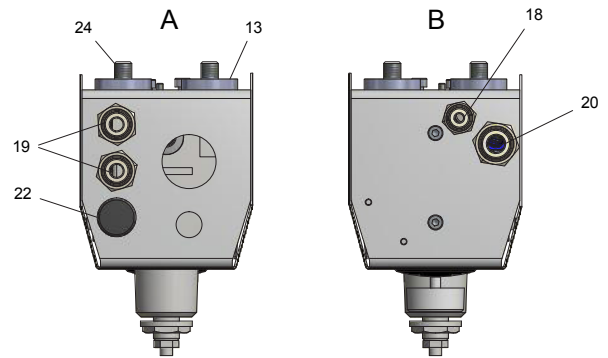
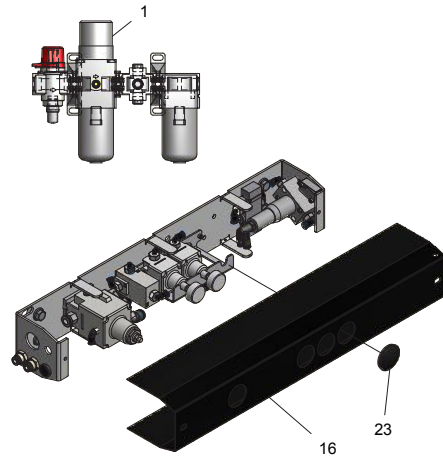

| Position | Designation / Function | Marking |
|----------|--------------------------------------|---------|
| 2 | 3/2 roller lever valve / Anti-jump | - |
| 4 | 3/2 valve / Reset | Reset |
| 8 | Precision regulator / Main regulator | - |
| 10A | Precision regulator / Without load | L0 |
| 10B | Precision regulator / With load | L1 |

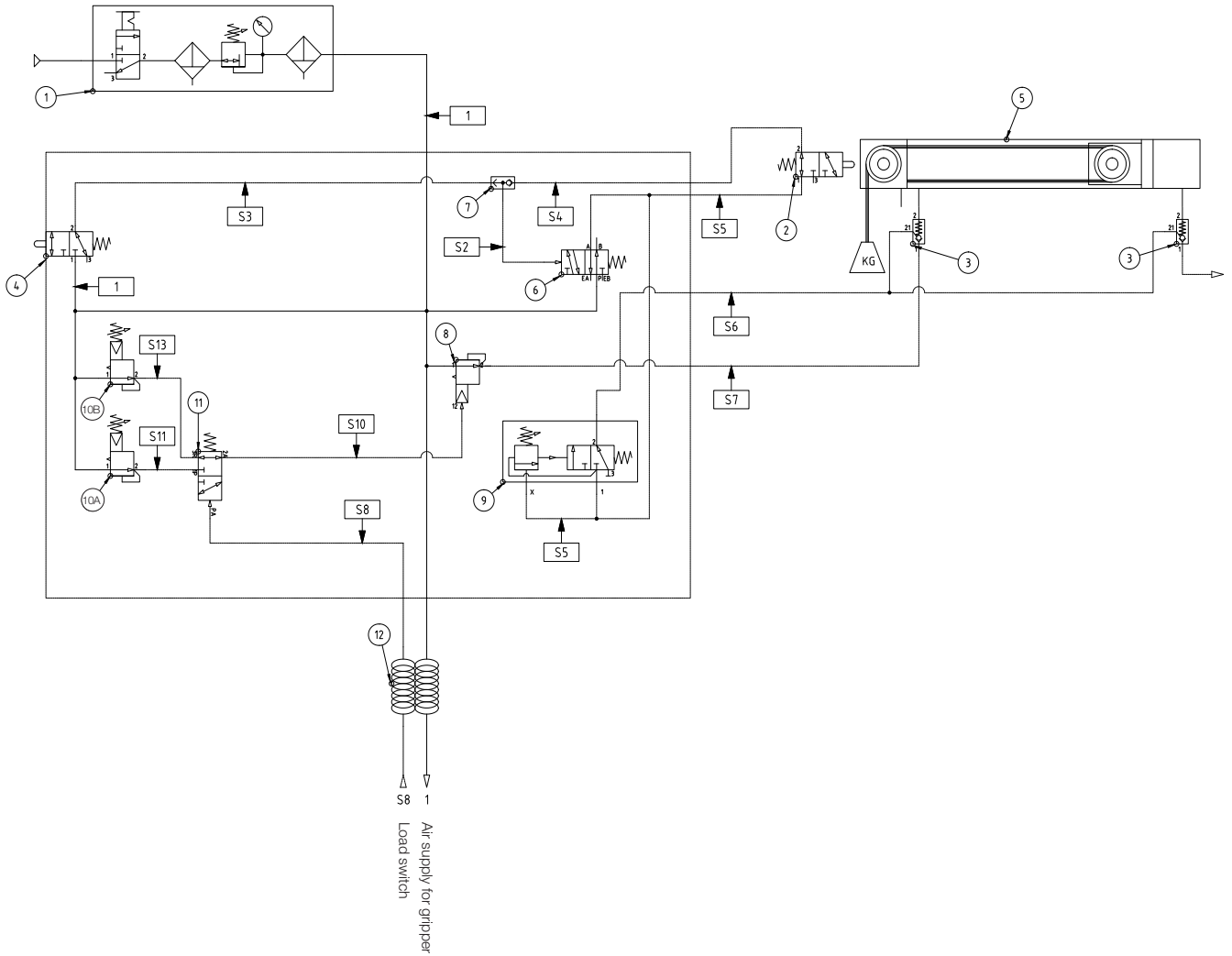

- Balanced 2-weight: handling of one balanced load; with an external actuator the operator selects "Load", or "Without load".

4.2 Pneumatics: 2-weight with slow speed function

| 741410 2-weight slow speed function | | | |
|-------------------------------------|-------------|-------------------------|----------|
| # | Article nr. | Designation | Quantity |
| 40 | 740920 | Slow speed function | 1 |
| 41 | 738880 | 2-weight | 1 |
| 42 | 740579 | Spiral hose, single 6/4 | 1 |

| 738880 2-weight | | | |
|-----------------|-------------|----------------------------|----------|
| # | Article nr. | Designation | Quantity |
| 1 | 735350 | Air preparation unit (FRL) | (1)* |
| 2 | 738874 | 3/2 valve NO | (1)** |
| 3 | 738875 | Non-return valve G3/8" | (1)** |
| 4 | 738876 | 3/2 valve NC | R 1 |
| 5 | 739772 | Attachment plate | 1 |
| 6 | 733374 | 5/2 valve, monostable | R 1 |
| 7 | 732669 | OR gate | R 1 |
| 8 | 731583 | Precision regulator | R 1 |
| 9 | 739553 | Pressure guard | R 1 |
| 10 | 738124 | Precision regulator | R 2 |
| 11 | 738125 | 3/2 valve monostable | R 1 |
| 12 | 732838 | Spiral hose, double 6/4 | 1 |
| 13 | 731806 | Washer 8,4x26x5 | 4 |
| 14 | 739776 | Bracket | 1 |
| 15 | 739233 | Plug G1/8" | 1 |
| 16 | 739773 | Cover | 1 |
| 17 | 740637 | Protection plate | 1 |
| 18 | 739270 | Push-in connector 4-4 | 1 |
| 19 | 739271 | Push-in connector 6-6 | 2 |
| 20 | 739272 | Push-in connector 8-8 | 1 |
| 21 | 738864 | Distance plate | 1 |
| 22 | 740533 | Rubber cover plate Ø14 | 1 |
| 23 | 741413 | Rubber cover plate Ø31,8 | 1 |
| 24 | 730218 | Screw M6SZ M8x16 | 4 |

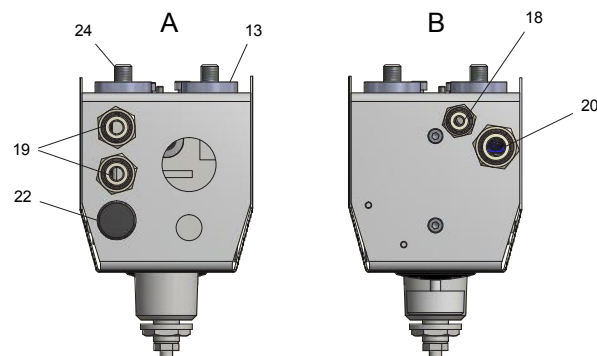
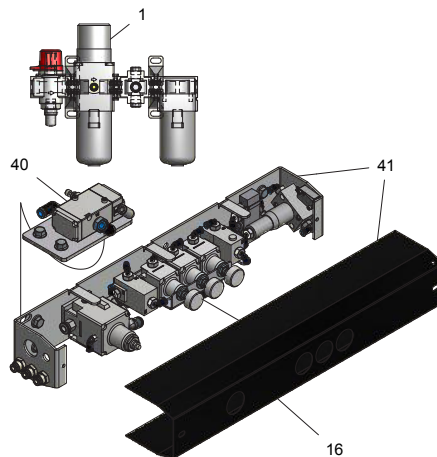

* Option
 ** Included in 739752 Front end

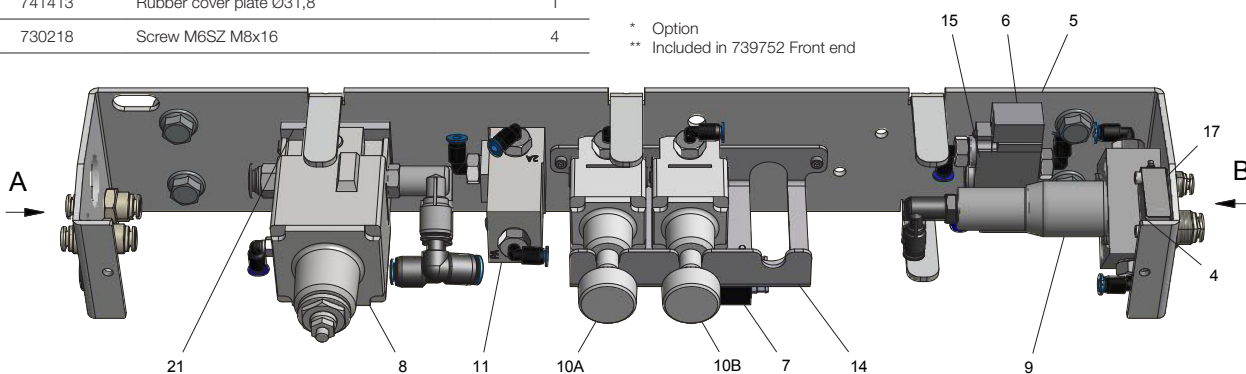

| 740920 Slow speed function | | | |
|----------------------------|-------------|-----------------------|----------|
| # | Article nr. | Designation | Quantity |
| 30 | 740645 | Attachment plate | 1 |
| 31 | 739551 | 3/2 valve NC | R 1 |
| 32 | 739550 | Flow control valve | R 1 |
| 33 | 730115 | MM8 t-slot nut single | 2 |
| 34 | 730216 | Screw M6SZ M8x12 | 2 |

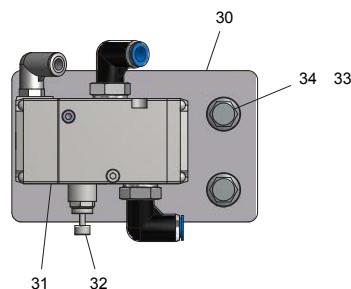

| Position | Designation / Function | Marking |
|----------|--------------------------------------|---------|
| 2 | 3/2 roller lever valve / Anti-jump | - |
| 4 | 3/2 valve / Reset | Reset |
| 8 | Precision regulator / Main regulator | - |
| 10A | Precision regulator / Without load | L0 |
| 10B | Precision regulator / With load | L1 |
| 31 | 3/2 valve / Slow speed function | - |

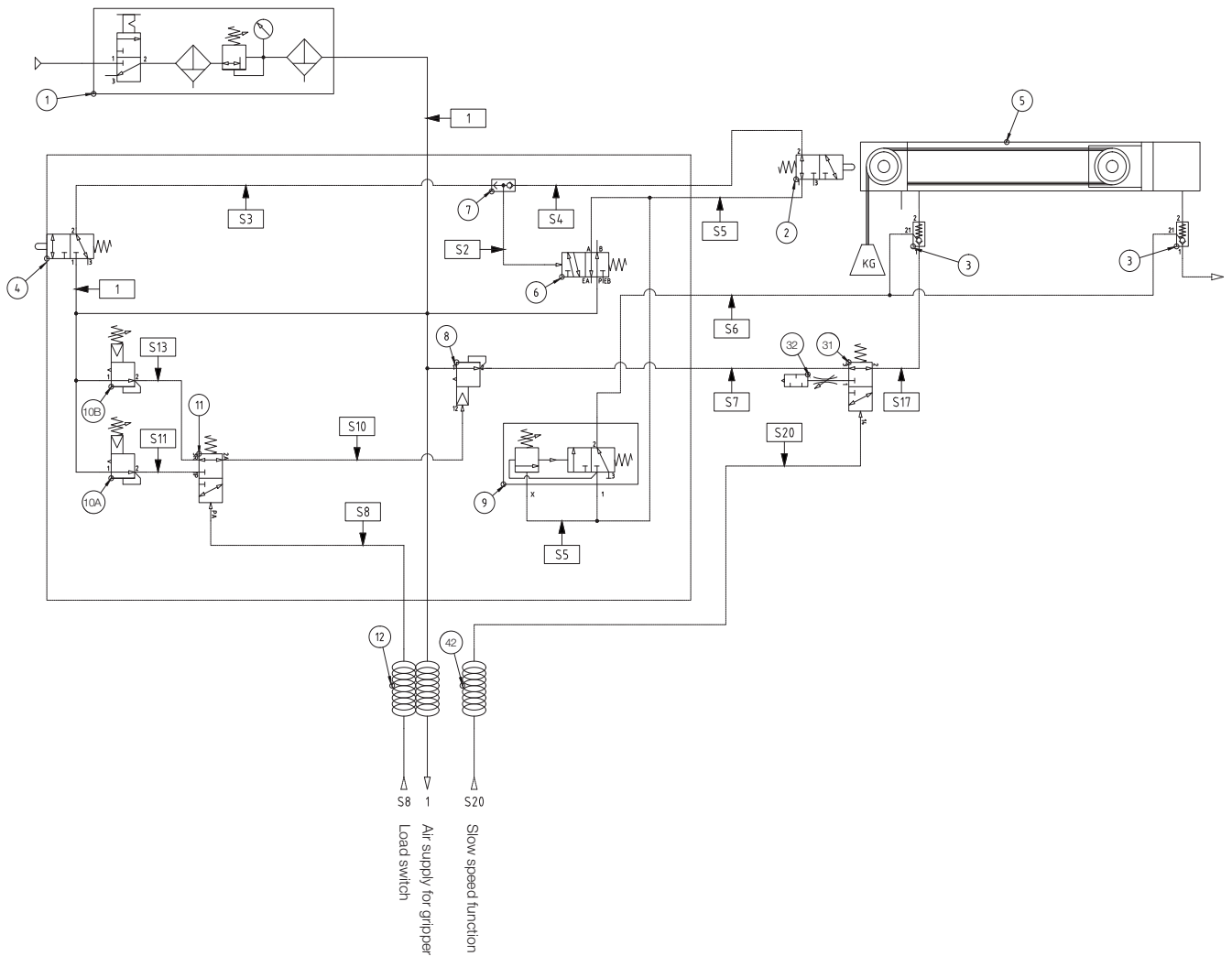

- Balanced 2-weight with slow speed function: handling of one balanced load; with an external actuator the operator selects "Load", or "Without load".
- The system is equipped with lowering function for a controlled lowering. Functional conditions are configured by the customer, and depend on the specific application.

4.3 Pneumatics: 3-weight

| # | Article nr. | Designation | Quantity |
|----|-------------|----------------------------|----------|
| 1 | 735350 | Air preparation unit (FRL) | (1)* |
| 2 | 738874 | 3/2 valve NO | (1)** |
| 3 | 738875 | Non-return valve G3/8" | (1)** |
| 4 | 738876 | 3/2 valve NC | R 1 |
| 5 | 739772 | Attachment plate | 1 |
| 6 | 733374 | 5/2 valve, monostable | R 1 |
| 7 | 732669 | OR gate | R 1 |
| 8 | 731583 | Precision regulator | R 1 |
| 9 | 739553 | Pressure guard | R 1 |
| 10 | 738124 | Precision regulator | R 3 |
| 11 | 738125 | 3/2 valve monostable | R 2 |
| 12 | 732838 | Spiral hose, double 6/4 | 1 |
| 13 | 740579 | Sprail hose, single 6/4 | 1 |
| 14 | 731806 | Washer 8,4x26x5 | 4 |
| 15 | 739776 | Bracket | 1 |
| 16 | 739773 | Cover | 1 |
| 17 | 739270 | Push-in connector 4-4 | 1 |
| 18 | 739272 | Push-in connector 8-8 | 1 |
| 19 | 738864 | Distance plate | 1 |
| 20 | 739233 | Plug G1/8" | 1 |
| 21 | 730218 | Screw M6SZ M8x16 | 4 |
| 22 | 739271 | Push-in connector 6-6 | 3 |
| 23 | 740637 | Protection plate | 1 |

* Option ** Included in 739752 Front end

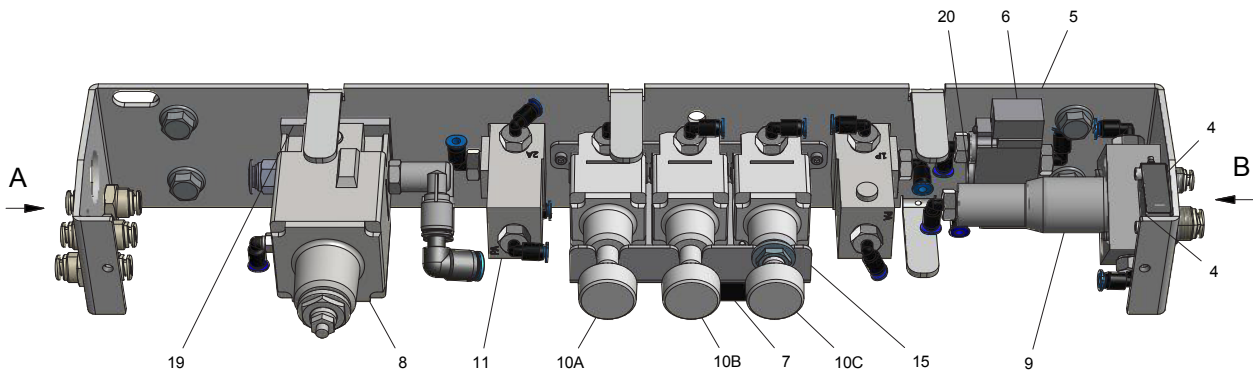
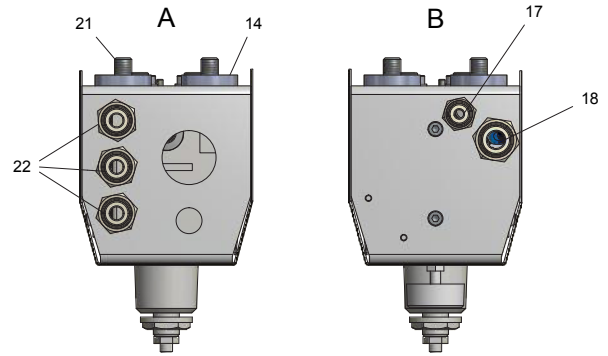
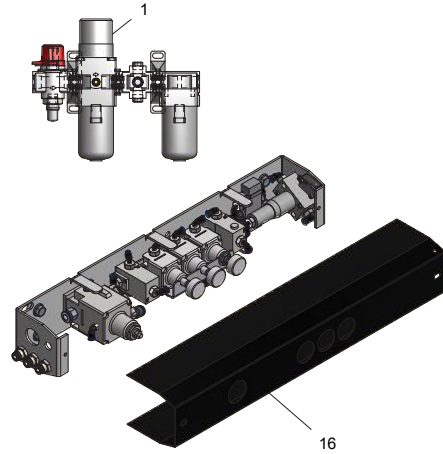

| Position | Designation / Function | Marking |
|----------|--------------------------------------|---------|
| 2 | 3/2 roller lever valve / Anti-jump | - |
| 4 | 3/2 valve / Reset | Reset |
| 8 | Precision regulator / Main regulator | - |
| 10A | Precision regulator / Without load | L0 |
| 10B | Precision regulator / With load 1 | L1 |
| 10C | Precision regulator / With load 2 | L2 |

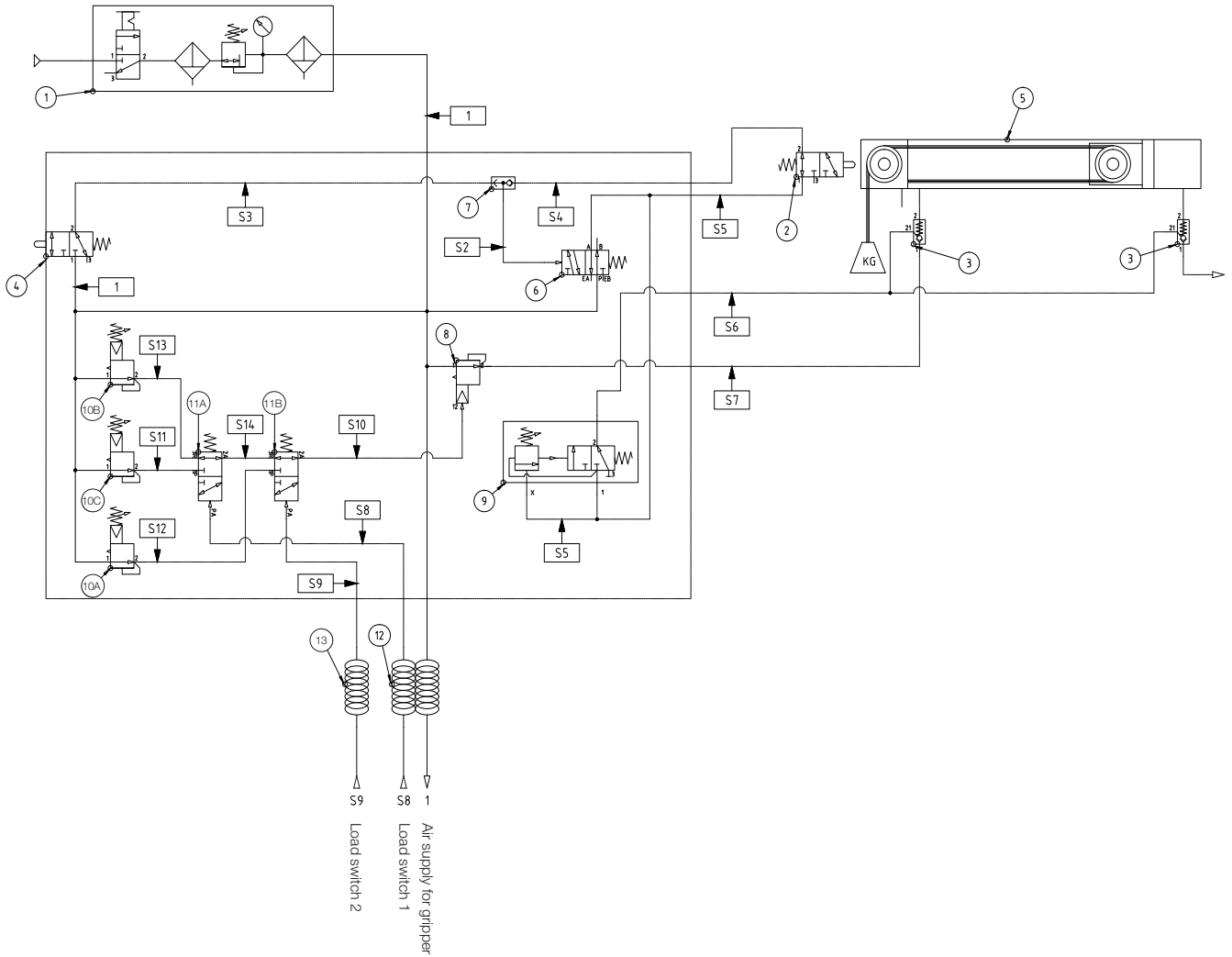

- Balanced 3-weight: handling of two balanced loads; with external actuator the operator selects "Load 1", "Load 2" or "Without load".

4.4 Pneumatics: 3-weight with slow speed function

| 741411 3-weight slow speed function | | | |
|-------------------------------------|-------------|-------------------------|----------|
| # | Article nr. | Designation | Quantity |
| 40 | 740920 | Slow speed function | 1 |
| 41 | 738881 | 3-weight | 1 |
| 42 | 740579 | Spiral hose, single 6/4 | 1 |

| 738881 3-weight | | | |
|-----------------|-------------|----------------------------|----------|
| # | Article nr. | Designation | Quantity |
| 1 | 735350 | Air preparation unit (FRL) | (1)* |
| 2 | 738874 | 3/2 valve NO | (1)** |
| 3 | 738875 | Non-return valve G3/8" | (1)** |
| 4 | 738876 | 3/2 valve NC | R 1 |
| 5 | 739772 | Attachment plate | 1 |
| 6 | 733374 | 5/2 valve, monostable | R 1 |
| 7 | 732669 | OR gate | R 1 |
| 8 | 731583 | Precision regulator | R 1 |
| 9 | 739553 | Pressure guard | R 1 |
| 10 | 738124 | Precision regulator | R 3 |
| 11 | 738125 | 3/2 valve monostable | R 2 |
| 12 | 732838 | Spiral hose, double 6/4 | 1 |
| 13 | 740579 | Spiral hose, single 6/4 | 1 |
| 14 | 731806 | Washer 8,4x26x5 | 4 |
| 15 | 739776 | Bracket | 1 |
| 16 | 739773 | Cover | 1 |
| 17 | 739270 | Push-in connector 4-4 | 1 |
| 18 | 739272 | Push-in connector 8-8 | 1 |
| 19 | 738864 | Distance plate | 1 |
| 20 | 739233 | Plug G1/8" | 1 |
| 21 | 730218 | Screw M6SZ M8x16 | 4 |
| 22 | 739271 | Push-in connector 6-6 | 3 |
| 23 | 740637 | Protection plate | 1 |

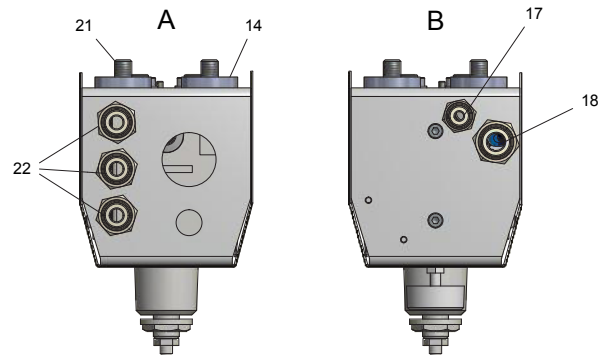
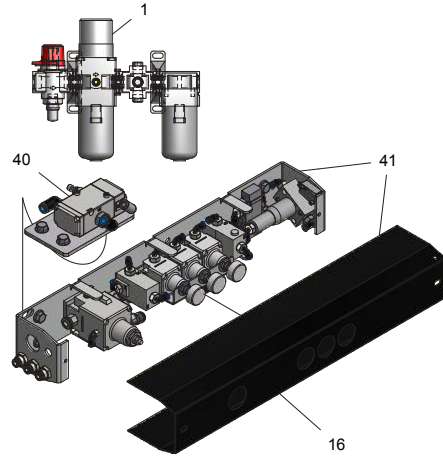

* Option ** Included in 739752 Front end

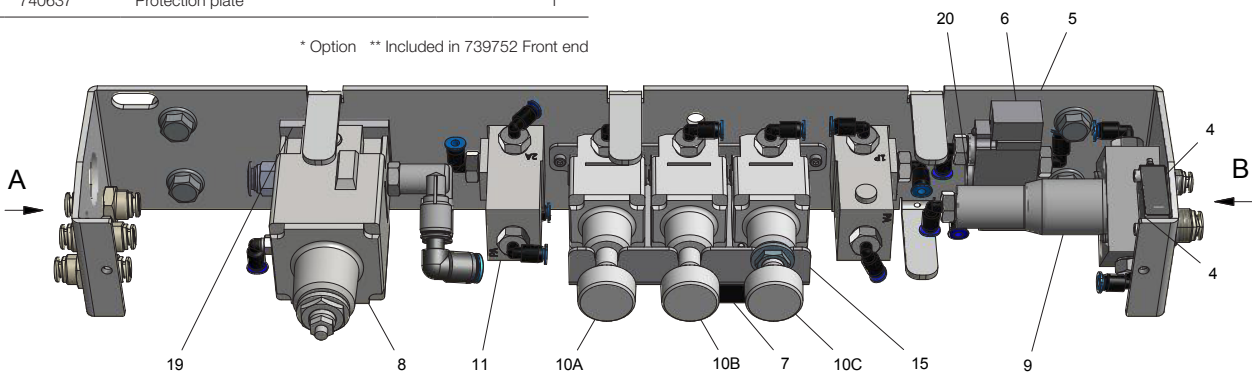

| 740920 Slow speed function | | | |
|----------------------------|-------------|-----------------------|----------|
| # | Article nr. | Designation | Quantity |
| 30 | 740645 | Attachment plate | 1 |
| 31 | 739551 | 3/2 valve NC | R 1 |
| 32 | 739550 | Flow control valve | R 1 |
| 33 | 730115 | MM8 t-slot nut single | 2 |
| 34 | 730216 | Screw M6SZ M8x12 | 2 |

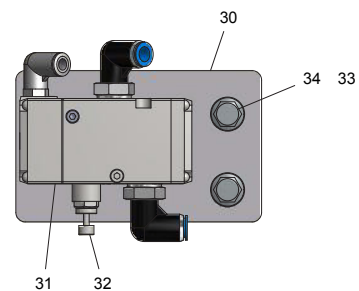

| Position | Designation / Function | Marking |
|----------|--------------------------------------|---------|
| 2 | 3/2 roller lever valve / Anti-jump | - |
| 4 | 3/2 valve / Reset | Reset |
| 8 | Precision regulator / Main regulator | - |
| 10A | Precision regulator / Without load | L0 |
| 10B | Precision regulator / With load 1 | L1 |
| 10C | Precision regulator / With load 2 | L2 |
| 31 | 3/2 valve / Slow speed function | - |

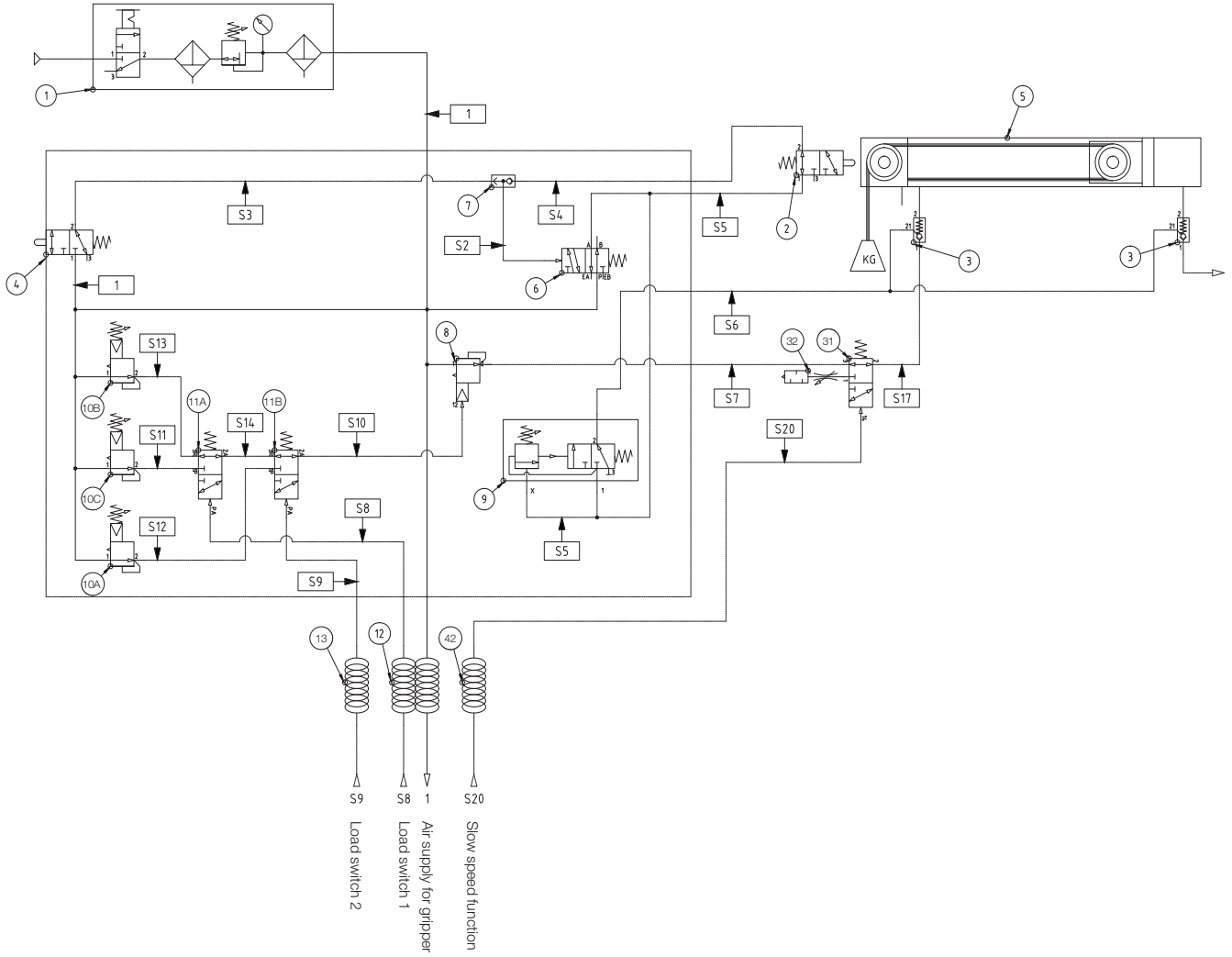

- Balanced 3-weight with slow speed function: handling of two balanced loads; with external actuator the operator selects "Load 1", "Load 2" or "Without load".
- The system is equipped with lowering function for a controlled lowering. Functional conditions are configured by the customer, and depend on the specific application.

4.5 Pneumatics: direct control

| 738882 | | Direct control | |
|--------|-------------|----------------------------|----------|
| # | Article nr. | Designation | Quantity |
| 1 | 735350 | Air preparation unit (FRL) | (1)* |
| 2 | 738874 | 3/2 valve NO | (1)** |
| 3 | 738875 | Non-return valve G3/8" | (1)** |
| 4 | 738876 | 3/2 valve NC | R 1 |
| 5 | 739772 | Attachment plate | 1 |
| 6 | 733374 | 5/2 valve, monostable | R 1 |
| 7 | 732669 | OR gate | R 1 |
| 8 | 740579 | Sprail hose, single 6/4 | 1 |
| 9 | 730219 | Screw M6SZ M8x20 | 2 |
| 10 | 731806 | Washer 8,4x26x5 | 4 |
| 11 | 740533 | Rubber cover plate Ø14 | 3 |
| 12 | 739773 | Cover | 1 |
| 13 | 739270 | Push-in connector 4-4 | 1 |
| 14 | 730513 | Wire joint | 2 |
| 15 | 739272 | Push-in connector 8-8 | 1 |
| 16 | 730218 | Screw M6SZ M8x16 | 2 |
| 17 | 738889 | Bracket for speed handle | 1 |
| 18 | 730693 | Wire, L=L1 | 1 |
| 19 | 738890 | Shackle M5 stainless | 1 |
| 20 | 730512 | Thimble | 2 |
| 21 | 740637 | Protection plate | 1 |
| 22 | 739233 | Plug G1/8" | 1 |
| 23 | 741413 | Rubber cover plate Ø31,8 | 3 |

* Option ** Included in 739752 Front end

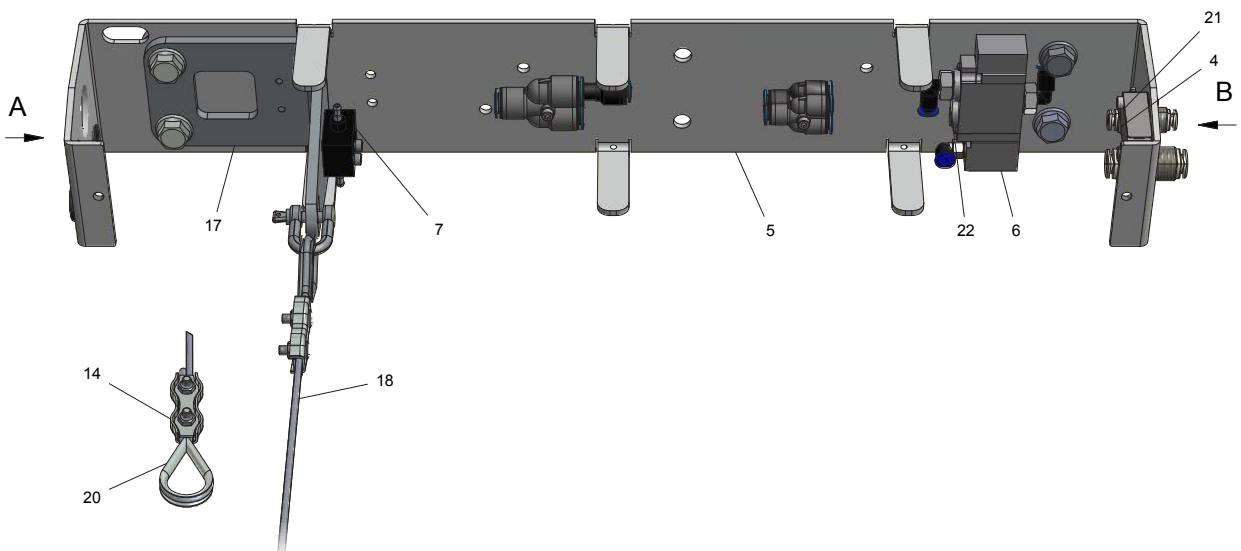
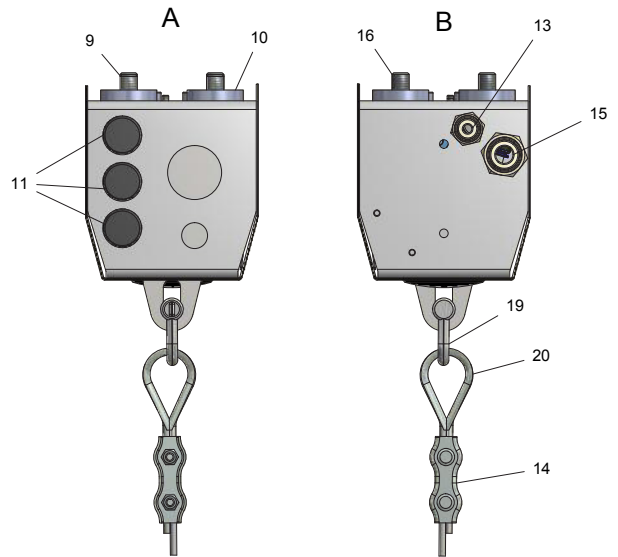
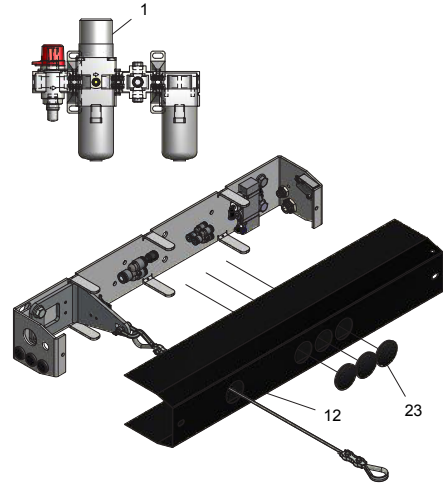

| Position | Designation / Function | Marking |
|----------|------------------------------------|---------|
| 2 | 3/2 roller lever valve / Anti-jump | - |
| 4 | 3/2 valve / Reset | Reset |

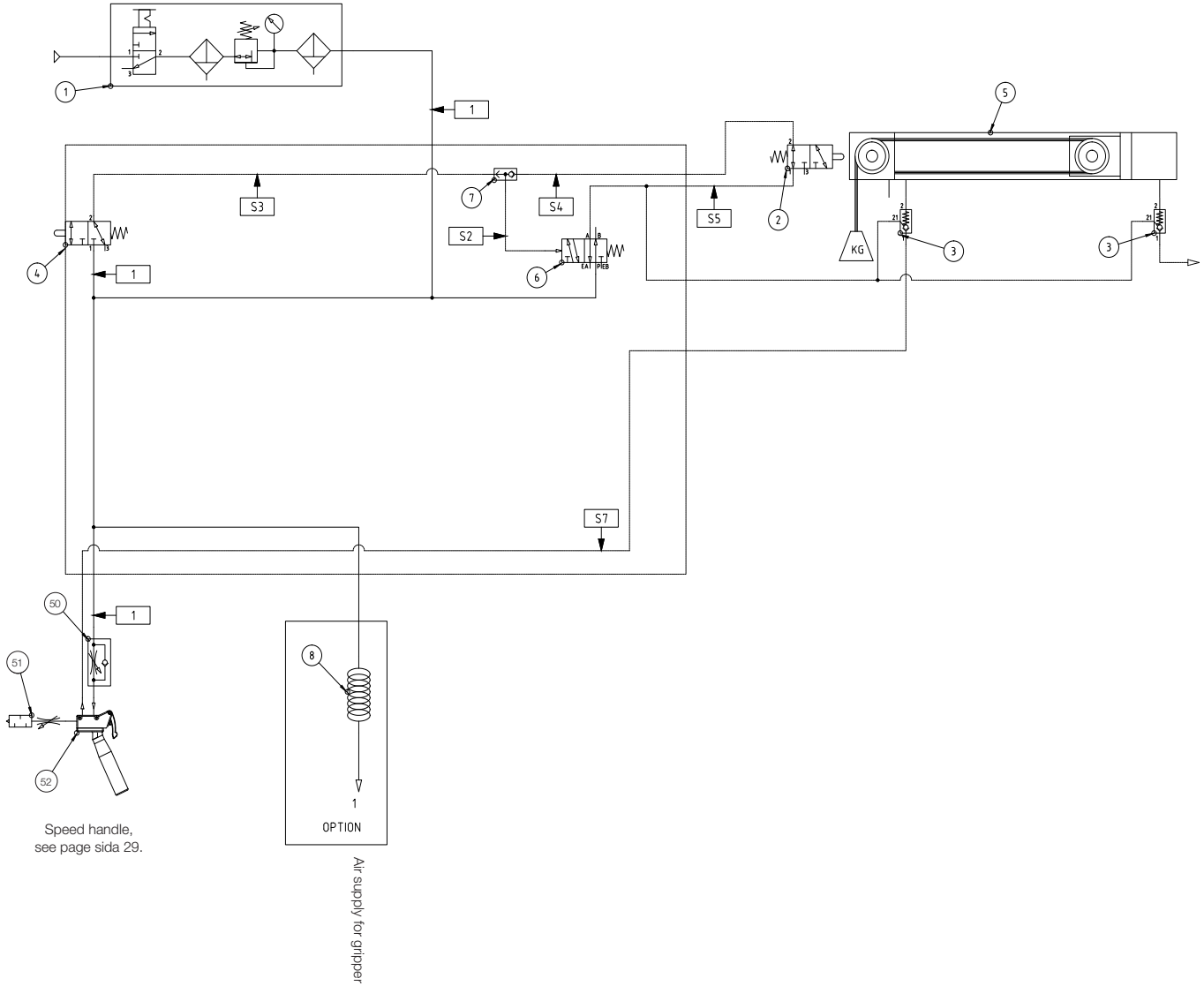

- Direct control: a precise and smooth handling of varying loads with a control unit. A convenient speed handle is available as standard control unit.

4.6 Pneumatics: direct control with load guard

| # | Article nr. | Designation | Quantity |
|----------------------------------|-------------|----------------------------|----------|
| 741400 Direct control load guard | | | |
| 1 | 735350 | Air preparation unit (FRL) | (1)* |
| 2 | 738874 | 3/2 valve NO | (1)** |
| 3 | 738875 | Non-return valve G3/8" | (1)** |
| 4 | 738876 | 3/2 valve NC | R 1 |
| 5 | 739772 | Attachment plate | 1 |
| 6 | 733374 | 5/2 valve, monostable | R 1 |
| 7 | 732669 | OR gate | R 1 |
| 8 | 740579 | Sprail hose, single 6/4 | 1 |
| 9 | 731806 | Washer 8,4x26x5 | 4 |
| 10 | 738889 | Bracket for speed handle | 1 |
| 11 | 739773 | Cover | 1 |
| 12 | 739553 | Pressure guard | R 1 |
| 13 | 738125 | 3/2 valve monostable | R 1 |
| 14 | 739272 | Push-in connector 8-8 | 1 |
| 15 | 730693 | Wire, L=L1 | 1 |
| 16 | 738890 | Shackle M5 stainless | 1 |
| 17 | 739270 | Push-in connector 4-4 | 1 |
| 18 | 730512 | Thimble | 2 |
| 19 | 740637 | Protection plate | 1 |
| 20 | 739233 | Plug G1/8" | 1 |
| 21 | 730513 | Wire joint | 2 |
| 22 | 739986 | Rubber cover plate Ø12 | 3 |
| 23 | 739271 | Push-in connector 6-6 | 3 |

* Option ** Included in 739752 Front end

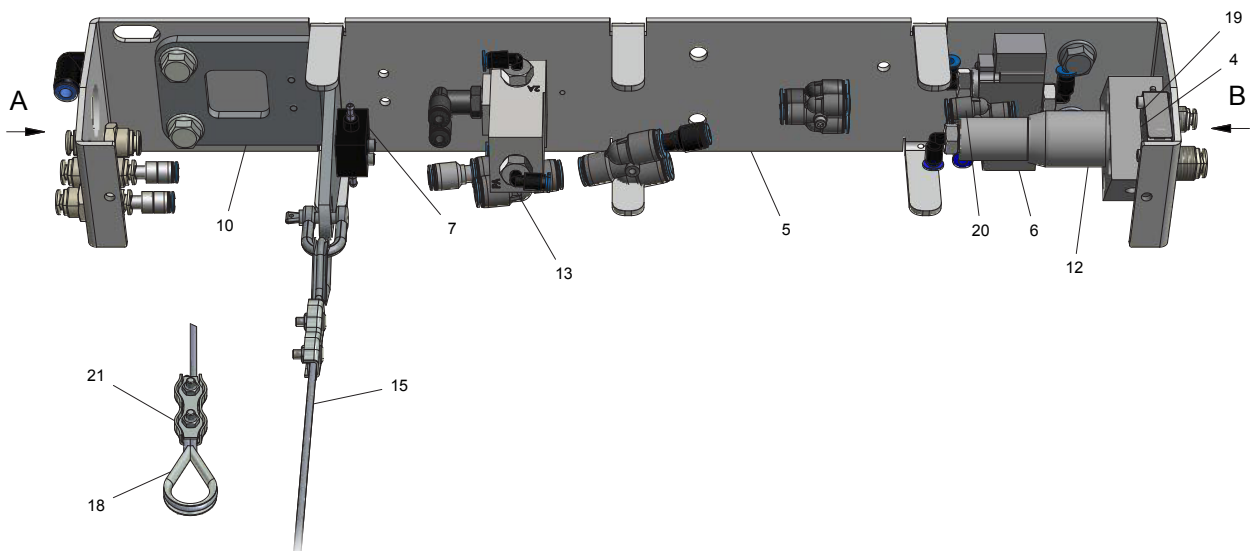
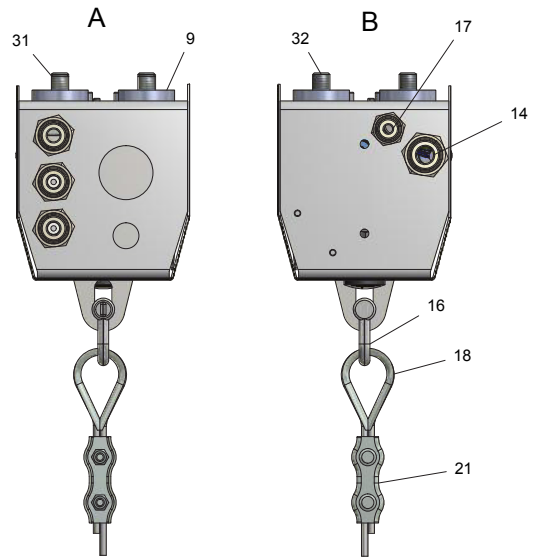
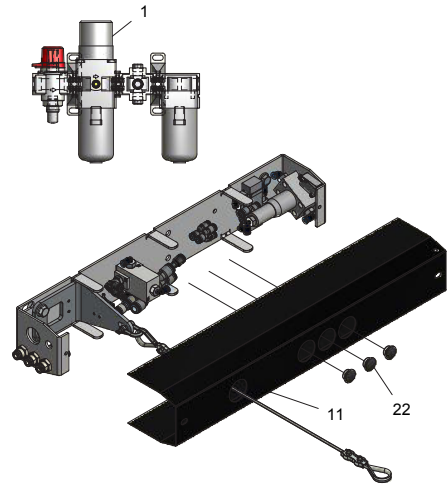

5. Options

5.1 Pneumatic load limiting kit

| 742276 | | Load limiting kit | | |
|--------|-------------|-----------------------------------|----------|---|
| # | Article nr. | Designation | Quantity | |
| 61 | 738125 | 3/2 valve monostable | R | 1 |
| 62 | 739551 | 3/2 valve NC | R | 1 |
| 63 | 739553 | Pressure guard | R | 2 |
| 64 | 741358 | Metering valve with silencer 3/8" | R | 1 |
| 65 | 742278 | Base plate | | 1 |
| 66 | 739255 | Push-in connector 8-8 | | 1 |
| 67 | 739272 | Push-in connector 8-8 | | 2 |
| 68 | 730215 | Screw M6SZ M8x10 | | 3 |
| 69 | 730115 | MM8 t-slot nut single | | 3 |

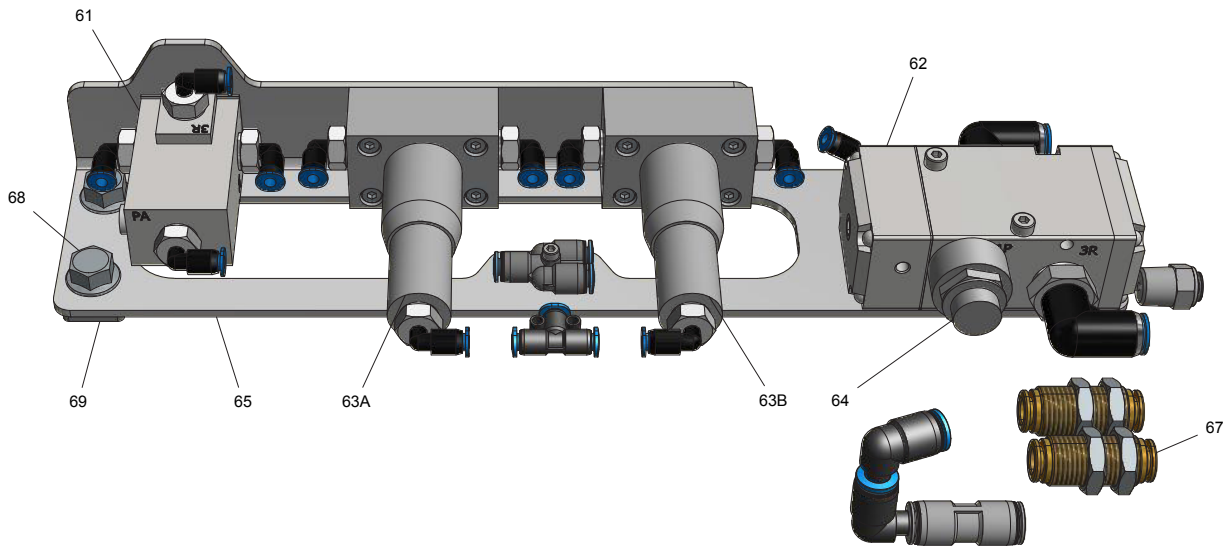
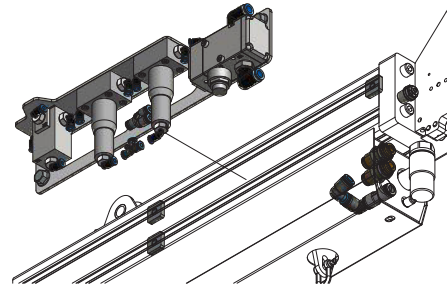

| Position | Designation / Function | Marking |
|----------|---|---------|
| 2 | 3/2 roller lever valve / Anti-jump | - |
| 4 | 3/2 valve / Reset | Reset |
| 12 | Pressure guard / Load guard | - |
| 63A | Pressure guard / Load limiting without load | P0 |
| 63B | Pressure guard / Load limiting with load | P1 |

742276 in combination with 741400
(is also an option to 738882)

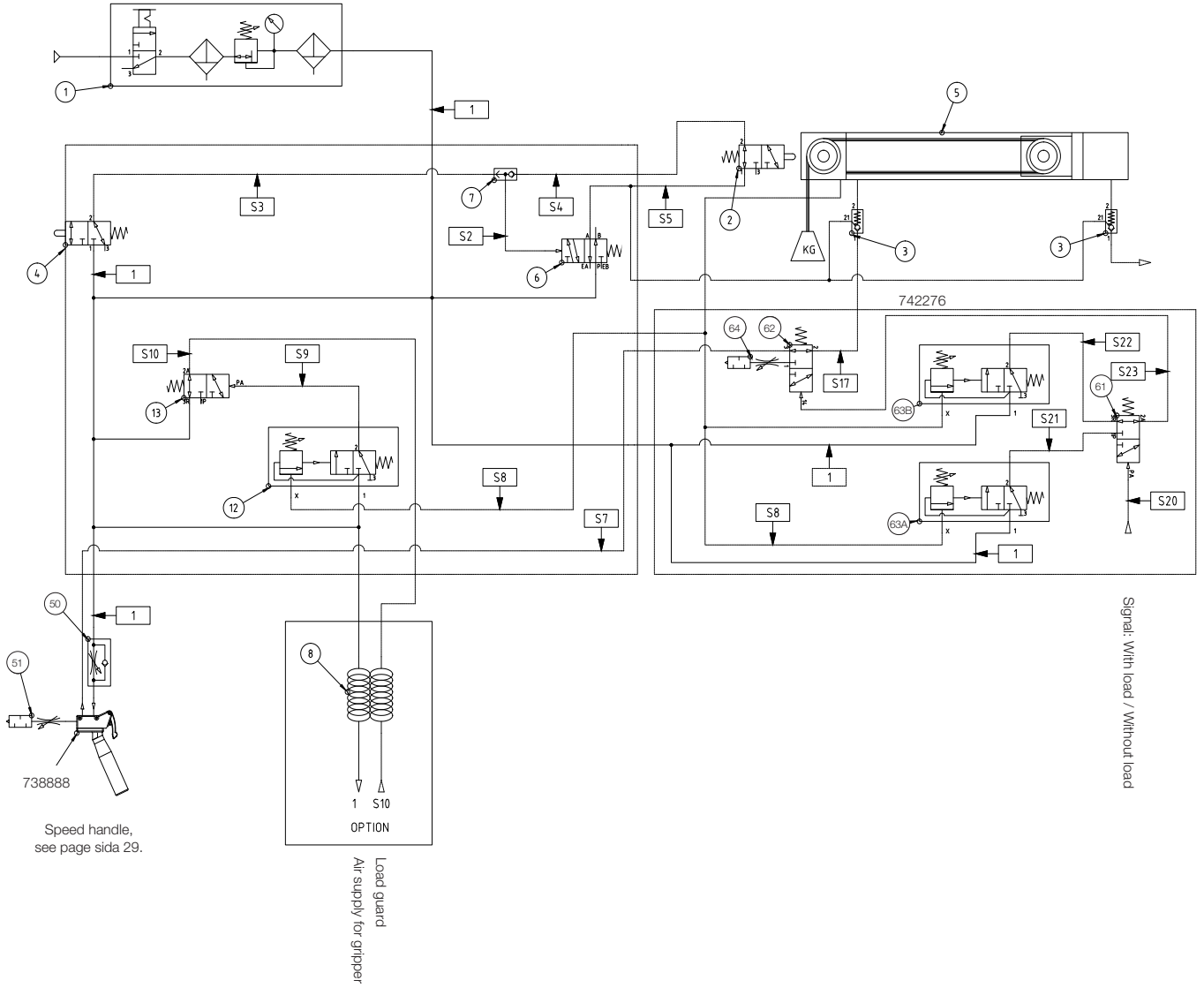

- The load limiting kit is used to restrict the lifting force of Mechline Pro. Both the lifting force at the state "no load" and "with load" can be restricted.

5.2 Air preparation unit

| 743057 FRL unit (C) | | | | |
|---------------------|-------------|-------------------------|----------|---|
| # | Article nr. | Designation | Quantity | |
| 1 | 730671 | Filter | S | 2 |
| 2 | 742427 | Submicro filter 0,01 µm | S | 1 |

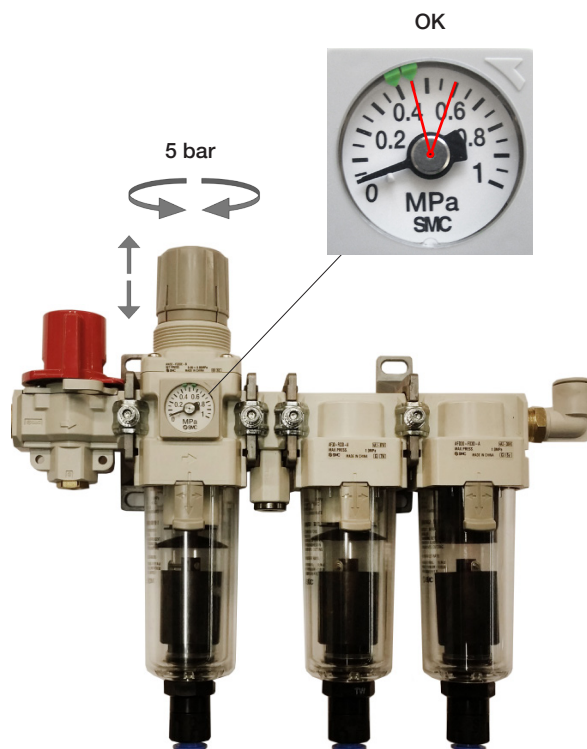

For connection to Mechline Pro.

742412

Push-in sleeve 12-8

7. Installation and commissioning

Mechline Pro is advantageously installed in Movomech rail system Mechrail or crane Mechcrane.

When the lifting unit is installed in trolleys of type LHB, the enclosed bushings* are used. These are not used when installed in a trolley type AHB1-2.

Mechline Pro must be used only with clean, filtered air, and is conveniently mounted in combination with an air preparation unit.

Regarding the gripper tool's function, see its documentation.

7.1 Initial adjustment: 2-weight

1. Install Mechline Pro, install the gripper tool and ensure that the shackle is securely locked (with cotter).
2. Plug in the air connection, the signal for load switching and eventual air supply to the gripper tool.
3. Verify that the screw knobs of both regulators are in their lowest position.
4. Turn on the air supply.
5. Adjust the regulator 'without load' (L0) to balance the load. The load should not sink or rise.
6. Grip the load with the tool and generate the lifter's signal for load switching. Adjust the regulator 'load' (L1) to balance the load. The load should not sink or rise.
7. Test the anti-jump function according to a separate instruction.

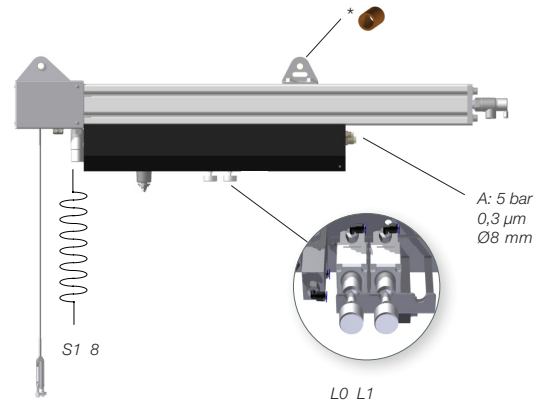

7.2 Initial adjustment: 3-weight

1. Install Mechline Pro, install the gripper tool and ensure that the shackle is securely locked (with cotter).
2. Plug in the air connection, the signal for load switching and eventual air supply to the gripper tool.
3. Verify that the screw knobs of all regulators are in their lowest position.
4. Turn on the air supply.
5. Adjust the regulator 'without load' (L0) to balance the load. The load should not sink or rise.
6. Grip the first load with the tool and generate the lifter's signal for load switching. Adjust the regulator 'load 1' (L1) to balance the load. The load should not sink or rise.
7. Grip the second load with the tool and generate the lifter's signal for load switching. Adjust the regulator 'load 2' (L2) to balance the load. The load should not sink or rise.
8. Test the anti-jump function according to a separate instruction.

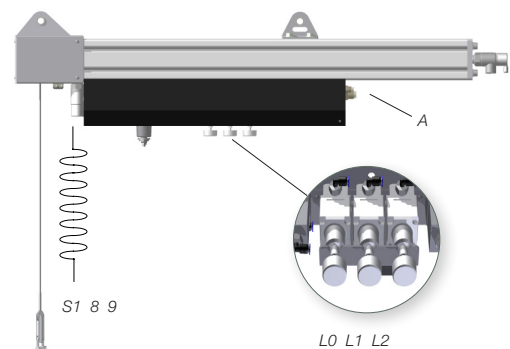

7.3 Initial adjustment: slow speed function

1. Install Mechline Pro according to the instructions for 2-weight or 3-weight.
2. Screw in the flow control valve completely.
3. Grip the load with the gripper tool.
4. Give a signal on S20.
5. Screw out the flow control valve until desired lowering speed is reached.
6. Remove the signal from S20.

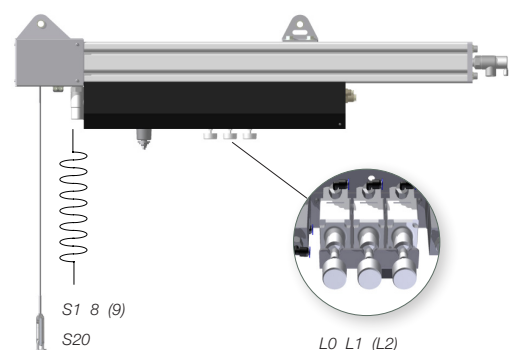

7.4 Initial adjustment: direct control with speed handle

1. Install Mechline Pro, install the gripper tool and ensure that the shackle is securely locked (with cotter).
2. Plug in the air connection, the signal for load switching and eventual air supply to the gripper tool.
3. Turn on the air supply.
4. Grip a load representative of the intended handling. Adjust the lifting and lowering speeds of the speed handle using its adjustment knobs.
5. Test the anti-jump function according to a separate instruction.

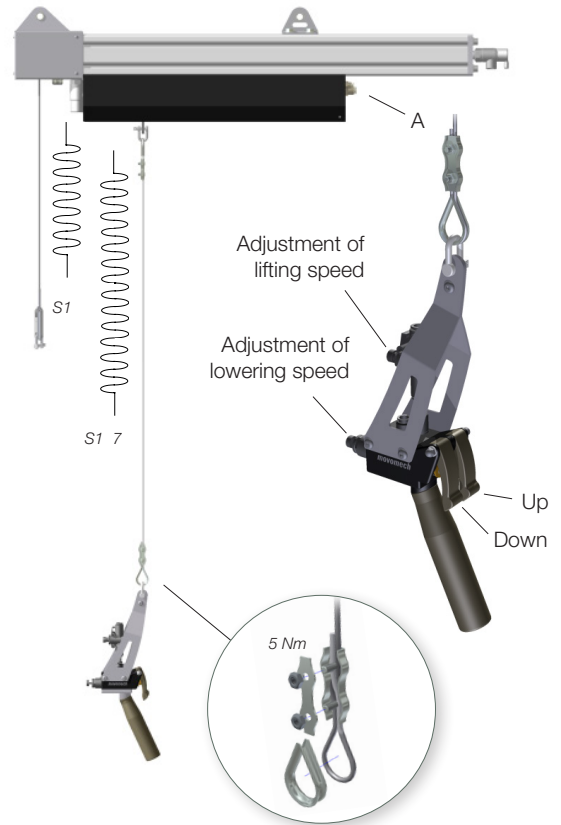

7.5 Initial adjustment: load guard

The load guard function detects if only the load of the gripper tool hangs in the lifting wire. The function can be used for loads over 10 kg.

1. Install Mechline Pro according to the instruction for direct control.
2. Ensure that only the gripper tool hangs in lifting wire.
3. If air is blowing out of S10, adjust the pressure guard until the air disappears.
4. Adjust the pressure switch until the air returns.
5. Grip the load with the gripper tool and lift it with the speed handle.
6. Check that the air is not blowing out of S10. (If air blows out, go back to step 3 and adjust the pressure switch with greater caution.)
7. S10 can now be used for example to provide pressure feed to "release" buttons.

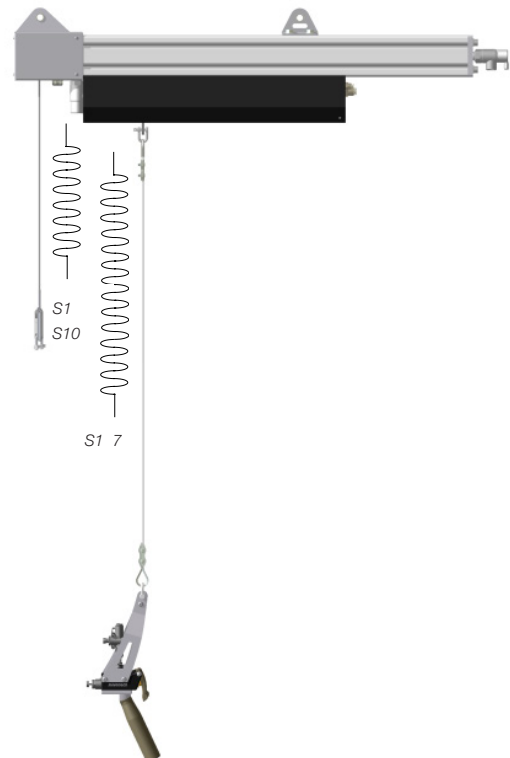

7.6 Initial adjustment: load limiting kit

The load limiting kit is used to restrict the lifting force of Mechline Pro.

Preparation

1. Screw both pressure guards maximum counter-clockwise to reset the pressure guards and allow unlimited max load. It may be easier to hold the sleeve with one hand and rotate the nut with the other.

Limitation of lifting force without load

2. Run Mechline Pro up to top position with the speed handle. Continue pressing when the top position is reached to raise the pressure in the chamber. The pressure guard without load will now release the pressure (seep) for several seconds.
3. Press down on the speed handle until Mechline Pro starts lowering.

4. Turn the nut on the pressure guard without load a few turns clockwise and repeat steps 2-3 until the time from that the Mechline Pro reaches the top position to the pressure switch releases the pressure is below 1 second. Now the pressure guard without load is set. Fine adjustment can be made by turning the nut. Do not forget to lock the nut when adjustment is set.

Limitation of lifting force with load

5. To set the maximum load with gripped detail, give a signal to the valve (signal: with load).
6. Then adjust the pressure guard with load according to steps 2-4.

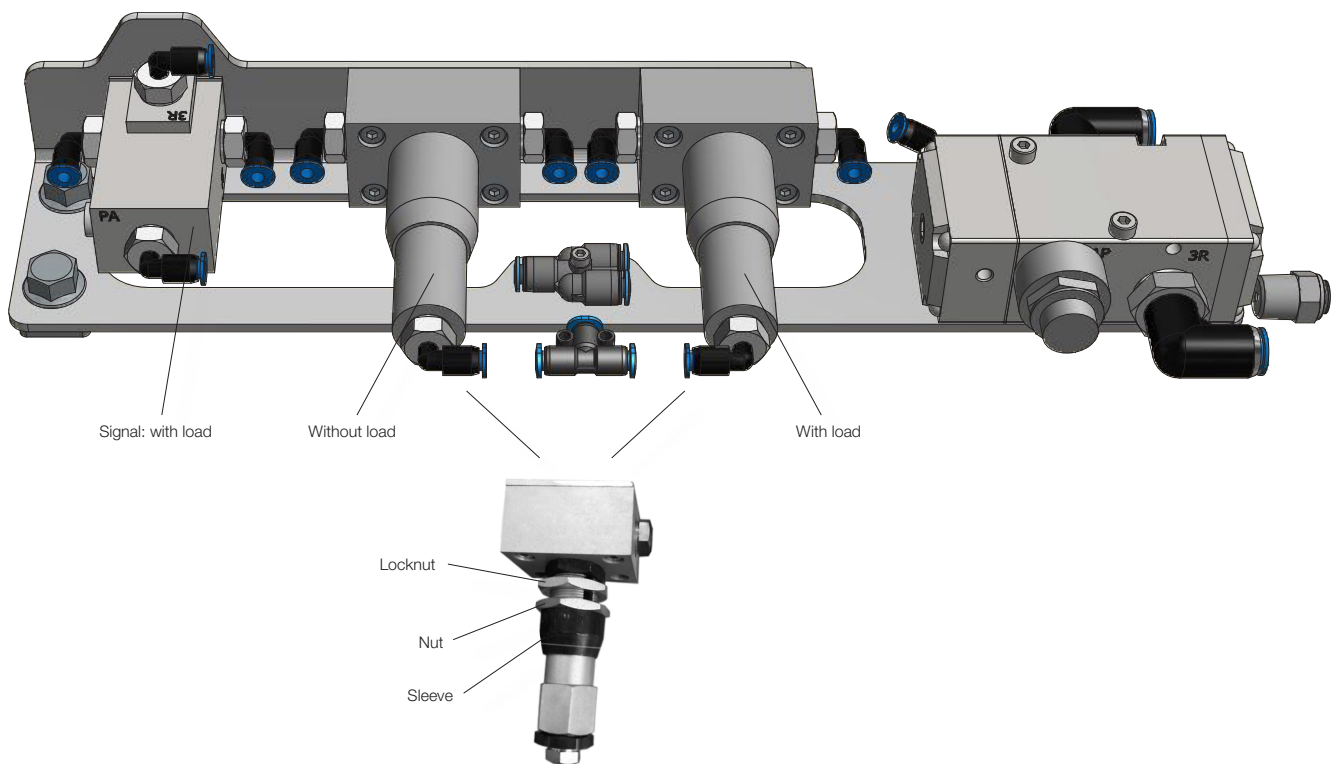

7.7 Mounting on Mechcrane Pro

The suspension should be moved to the rear end of Mechline Pro when mounted in a Mechcrane crane, in order to avoid collision with eventual cable trolleys (in absence of travel limit).



8. User instructions

The operation of pneumatic Mechline Pro is largely dependent on its specific application:

- its configuration with or without a gripper tool
- gripper design and functionality
- characteristics and variability of the handled object
- the surrounding work environment
- intended work pace as well as usage frequency

2-weight

2-weight Mechline Pro is used for handling a fixed load level, i.e. handling with 'no load' or with 'load'. When the lifting unit receives a pneumatic signal for load switching (see pneumatic diagram), the load is equilibrated and the operator can handle the object/gripper in a so-called "weightless" state.

3-weight

3-weight Mechline Pro is used for handling two fixed load levels, i.e. handling with 'no load', with 'load 1' and with 'load 2'. When the lifting unit receives a pneumatic signal for load switching (see pneumatic diagram), the load is equilibrated and the operator can handle the object/gripper in a so-called "weightless" state.

Slow speed function

The pneumatic versions 2-weight and 3-weight can be equipped with a slow speed function for controlled lowering. Functional conditions are configured by the customer, and the user instructions depend on the specific application.

Direct control with speed handle

Direct controlled Mechline Pro with speed handle is used for handling various loads up to 50 kg. The operator can lift the handled object/gripper using the push buttons on the speed handle.

The lifting and lowering movements of Mechline is dynamic in the end positions, which gives a feeling of "softness" in the handling – an advantage during assembly work and manual adjustment.

If the load level is changed and the operator wishes to adjust the lifting or lowering speed, this can be done using the adjustment knobs on the speed handle.

Load guard

The pneumatic version direct control can be equipped with a load guard, to be configured by the customer; e.g. to only allow activation of the release function if the gripper tool is unloaded. The user instructions depend on the specific application.

A complete workstation, including Mechline Pro, must be accompanied by a specific operating instruction for the particular application, taking into account the mentioned factors.

For a function description of the pneumatic versions of Mechline Pro, see section Pneumatics.

Before and during use

- Do not use the lifting unit when any kind of damage on the lifting unit, lifting wire, swivel or its gripping tool.
- Ensure that the shackle is securely locked (with cotter) before use.
- Never lift a heavier load than allowed, total load includes total load of gripping tool and handled object.
- Mechline Pro is equipped with an anti-jump function, intended to prevent unwanted lifting, for example, if a load is dropped or if an internal pressure is accumulated in the lifter. It is not intended to be used as an end stop or travel limit.
- Ensure that the handled object or gripper tool is not locked or risk being trapped during the movement / lifting motion (A). When lifting a stuck object, an increased air pressure can be built up in the lifter, possibly causing unwanted and abrupt movements. These are limited by the anti-jump function, but cannot be eliminated completely.
- If the anti-jump function has been triggered, the lifting unit is reset in normal mode with a push button Reset at the end of the pneumatic cabinet. If the gripper tool carries a load at the time, let it remain in the gripper while resetting the lifter.
- The lifter is not intended for use with gripping tool in the form of hook or similar.
- The operator may not be in close proximity to the wire while operating the lifter (B).
- The lifting unit should always be positioned vertically above the handled object during the lifting operation (C).

For further instructions regarding operating, see documentation of the specific gripper tool.

Prohibited use



A Risk of entrapment of object

B Operator close to lifting wire

C Lifting unit not above object

9. Service, maintenance & running

A general review and functional control tests are performed on a regular basis during commissioning.

All service and maintenance shall be recorded. The user should make sure that material for the purpose is easily available.

NOTE: Make sure that damaged components are replaced immediately in order to avoid possible personal and material damage.

Keep the equipment and area on and adjacent to the workplace cleaned. This is important for the comfort and well-being of personnel and facilitates service and maintenance. Dirt gives a clear indication of the equipment not being properly maintained, which may possibly affect the remaining guarantees on the equipment.

Maintenance safety instructions

The prescribed procedures and service intervals, including those concerning the replacement of parts/accessories, are described in the instruction manual and must be followed. Professionals are the only persons who are allowed to carry out such procedures.

Staff members with appropriate competence and authority are the only persons who are allowed to carry out mechanical and electrical repair and maintenance work. Unauthorised persons should be prohibited to work with machines and devices inside the equipment.

The equipment should be disconnected and secured against unintentional or unauthorised use, including reconnection, during all repair and maintenance work.

It should be confirmed that the equipment is free from voltage before any work on electric equipment is commenced.

Make sure that:

- moving parts are stationary and locked, and that
- moving parts cannot move accidentally during maintenance work.

Use safe and environmentally friendly maintenance products and spare parts!

Directions for work during operation

The user or the "authorised person" must, in each individual case, ensure that the work in question can be carried out without any risk of personal injury because of specific local conditions.

To prevent accidents, only approved and suitable tools and aids may be used during maintenance, adjustment and repair work.

Do not touch rotating parts. Maintain an adequate safe distance between yourself and the machinery to prevent clothes, limbs and hair from becoming caught.

Avoid the occurrence of naked flame, extreme heat (e.g. welding) and sparks in the presence of volatile cleaning materials and nearby inflammable or heat-sensitive materials (e.g. wood, plastics, oils, fats and electric equipment). This can result in fire hazard, harmful gases and damaged insulation.

Directions for work with pneumatic equipment

The equipment should be stopped immediately on discovery of faults related to the air supply.

Work on pneumatic equipment or parts must only be carried out by authorised staff.

The parts on which inspection, maintenance and repair work is to be carried out should be disconnected from the air supply.



Keep the equipment and area on and adjacent to the workplace cleaned.

9.1 Recommended spare parts / wear parts

| 73886x | | Base model Mechline Pro 50 | | |
|--------|-------------|----------------------------|---|----------|
| # | Article nr. | Designation | | Quantity |
| 3 | 738858 | Wire with loop, complete | S | 1 |
| 7 | 738875 | Non-return valve G3/8" | R | 2 |
| 8 | 739704 | Swivel | R | 1 |
| 19 | 742386 | O ring | S | 1 |
| 20 | 742156 | Shrink tubing 2,4/1,2 | S | 0,02 |

| 738852 | | Piston, complete | | |
|--------|-------------|-----------------------|---|----------|
| # | Article nr. | Designation | | Quantity |
| 5 | 740622 | Piston seal | S | 1 |
| 7 | 739933 | Rear pulley, complete | R | 1 |

| 739752 | | Front end | | |
|--------|-------------|------------------------|---|----------|
| # | Article nr. | Designation | | Quantity |
| 4 | 739934 | Front pulley, complete | R | 1 |
| 5 | 738874 | 3/2 valve NO | R | 1 |
| 6 | 742431 | Wire guiding | S | 1 |
| 9 | 738232 | O ring | S | 1 |
| 13 | 730449 | Rubber damper | S | 1 |
| 16 | 731049 | O ring | S | 1 |
| 21 | 740538 | Sealing | S | 1 |

| 738880 | | 2-weight | | |
|--------|-------------|-----------------------|---|----------|
| # | Article nr. | Designation | | Quantity |
| 4 | 738876 | 3/2 valve NC | R | 1 |
| 6 | 733374 | 5/2 valve, monostable | R | 1 |
| 7 | 732669 | OR gate | R | 1 |
| 8 | 731583 | Precision regulator | R | 1 |
| 9 | 739553 | Pressure guard | R | 1 |
| 10 | 738124 | Precision regulator | R | 2 |
| 11 | 738125 | 3/2 valve monostable | R | 1 |

| 738881 | | 3-weight | | |
|--------|-------------|-----------------------|---|----------|
| # | Article nr. | Designation | | Quantity |
| 4 | 738876 | 3/2 valve NC | R | 1 |
| 6 | 733374 | 5/2 valve, monostable | R | 1 |
| 7 | 732669 | OR gate | R | 1 |
| 8 | 731583 | Precision regulator | R | 1 |
| 9 | 739553 | Pressure guard | R | 1 |
| 10 | 738124 | Precision regulator | R | 3 |
| 11 | 738125 | 3/2 valve monostable | R | 2 |

| 741410 | | 2-weight slow speed function | | |
|---------------------|--|------------------------------|--|--|
| See 738880 + 740920 | | | | |

| 741411 | | 3-weight slow speed function | | |
|---------------------|--|------------------------------|--|--|
| See 738881 + 740920 | | | | |

| 740920 | | Slow speed function | | |
|--------|-------------|---------------------|---|----------|
| # | Article nr. | Designation | | Quantity |
| 31 | 739551 | 3/2 valve NC | R | 1 |
| 32 | 739550 | Flow control valve | R | 1 |

| 738882 | | Direct control | | |
|--------|-------------|-----------------------|---|----------|
| # | Article nr. | Designation | | Quantity |
| 4 | 738876 | 3/2 valve NC | R | 1 |
| 6 | 733374 | 5/2 valve, monostable | R | 1 |
| 7 | 732669 | OR gate | R | 1 |

| 741400 | | Direct control load guard | | |
|--------|-------------|---------------------------|---|----------|
| # | Article nr. | Designation | | Quantity |
| 4 | 738876 | 3/2 valve NC | R | 1 |
| 6 | 733374 | 5/2 valve, monostable | R | 1 |
| 7 | 732669 | OR gate | R | 1 |
| 12 | 739553 | Pressure guard | R | 1 |
| 13 | 738125 | 3/2 valve monostable | R | 1 |

| 738888 | | Speed handle | | |
|--------|-------------|----------------------------------|---|----------|
| # | Article nr. | Designation | | Quantity |
| 1 | 738865 | Valve spool, complete | R | 2 |
| 9 | 739919 | Flow control valve with silencer | R | 1 |
| 10 | 738895 | Flow control valve | R | 1 |
| 17 | 730675 | Hose, d=8 | R | L |
| 18 | 731613 | Protection hose | R | L |

| 743057 | | FRL unit (C) | | |
|--------|-------------|-------------------------|---|----------|
| # | Article nr. | Designation | | Quantity |
| 1 | 730671 | Filter | S | 2 |
| 2 | 742427 | Submicro filter 0,01 µm | S | 1 |

| 742276 | | Load limiting kit | | |
|--------|-------------|-----------------------------------|---|----------|
| # | Article nr. | Designation | | Quantity |
| 61 | 738125 | 3/2 valve monostable | R | 1 |
| 62 | 739551 | 3/2 valve NC | R | 1 |
| 63 | 739553 | Pressure guard | R | 2 |
| 64 | 741358 | Metering valve with silencer 3/8" | R | 1 |

| 742157 | | Service kit | | |
|--------|-------------|---|---|----------|
| # | Article nr. | Designation | | Quantity |
| 1 | 738858 | Wire with loop, complete | S | 1 |
| 2 | 740538 | Sealing | S | 1 |
| 3 | 738232 | O ring | S | 1 |
| 4 | 731049 | O ring | S | 1 |
| 5 | 740622 | Piston seal | S | 1 |
| 6 | 742386 | O ring | S | 1 |
| 7 | 731717 | Grease Klübersynth LF44-22, 40 g in pot | | 1 |
| 8 | 742156 | Shrink tubing 2,4/1,2 | S | 0,02 |

9.2 Service record – Mechline Pro 50

| ID: Service by: | | Client/ place: Date: | Interval in months when 1-3 shifts | Interval in months when >3 shifts | The service record shall be kept by the client/user. | 1/1 |
|--|--|---|------------------------------------|-----------------------------------|--|---------|
| Visual inspection, examine whether the product exhibits damages Auditory inspection, examine whether the product exhibits discordant sound Physical inspection, examine whether the product exhibits damages Mechanical inspection, examine whether the product exhibits decomposition, instruments is needed | | * If applicable. The service must be performed considering the maintenance safety instruction. | | | | |
| No | Product | Inspection | | | Inspector Dept. / Sign. | Comment |
| 1 | <u>Base model</u> | General overview. | 4 | 3 | | |
| 1.1 | Fasteners | | 4 | 3 | | |
| 1.2 | Wire | General overview. The wire must be replaced at least every 300,000 work cycles, or if damaged, see section 9.3. | 1 | 1 | | |
| 1.3 | Swivel | General overview, verify smooth rotation. Note that the cable's lifespan can be reduced considerably if swivel rotation is uneven or strident! | 4 | 3 | | |
| 2 | <u>Pneumatics</u> | General overview. | 4 | 3 | | |
| 2.1 | Fasteners | | 4 | 3 | | |
| 2.2 | Hoses | Check hoses and fittings. | 4 | 3 | | |
| 2.3 | Filter regulator with manual drainage | Open the blowdown valve from time to time to blow out collected condensate. Do not allow the liquid level to exceed: "Max drain level". | 1 | 1 | | |
| 2.4 | Micro regulator with manual drainage | Open the blowdown valve from time to time to blow out collected condensate. Do not allow the liquid level to exceed: "Max drain level". Filter element is replaced when the pressure drop across the filter reaches 0.1 MPa, and at least once a year. | 1 | 1 | | |
| 2.5 | Anti-jump function | Function test: see section 9.5. | 1 | 1 | | |
| 3 | <u>Control unit*</u> | General overview. | 1 | 1 | | |
| 3.1 | <ul style="list-style-type: none"> • Button • Turning button • Sensor • Speed handle | Test: drive the hoist in all applicable situations. | 1 | 1 | | |
| 4 | <u>Tool adapter*</u> | General overview. | 4 | 3 | | |
| 4.1 | Fasteners | | 4 | 3 | | |

9.3 Replacement of wire

The wire must be replaced at least every 300,000 work cycles, or if damaged. At the same occasion, o-rings and seals are replaced.

1. Disconnect the lifter's air supply.
2. Remove the front cover and the screws of the front end, then separate the front end from the MP80C profile. Take out the piston from the MP80C profile. (A.)
3. Detach the old wire at the wire lock (B) and the set screw (C), then remove it from the piston and the front end (B).
4. Remove the screws fixing the front end cap to the pulley housing, and separate the parts.
5. On the front end, replace o-rings (D), seal (E) and wire guiding (F).
6. Replace the seal on the piston (G).
7. Verify that the front and rear pulleys roll smoothly and without noise.
8. Cut the new wire in the same length as the previous wire.
9. Enter the wire through the wire guiding (F), over the front pulley, over the rear pulley of the piston, and back out through the wire lock.

Peel the wire approx. 90 mm from the end (B: red marking), mount shrink tubing approx. 2 cm (C: yellow marking), flex the wire end into the fastening hole and fix it with the set screw (C). Create a loop and attach the wire in the wire lock (B).

Verify that the wire is fitted correctly in the wire lock slot, and that the section of the wire that runs through the wire lock is peeled. The screws of the wire lock must be oiled and alternately tensioned with 10 Nm + 1/8 turn.

10. Verify that the sensor is just outside the flyweights of the front pulley, without being in contact (H).
11. Remount the front end cap on the front end.
12. Enter the piston in the MP80C profile and remount the front end on the MP80C profile.
13. Remount the front cover and reconnect the air supply to the lifter. Test the anti-jump function.

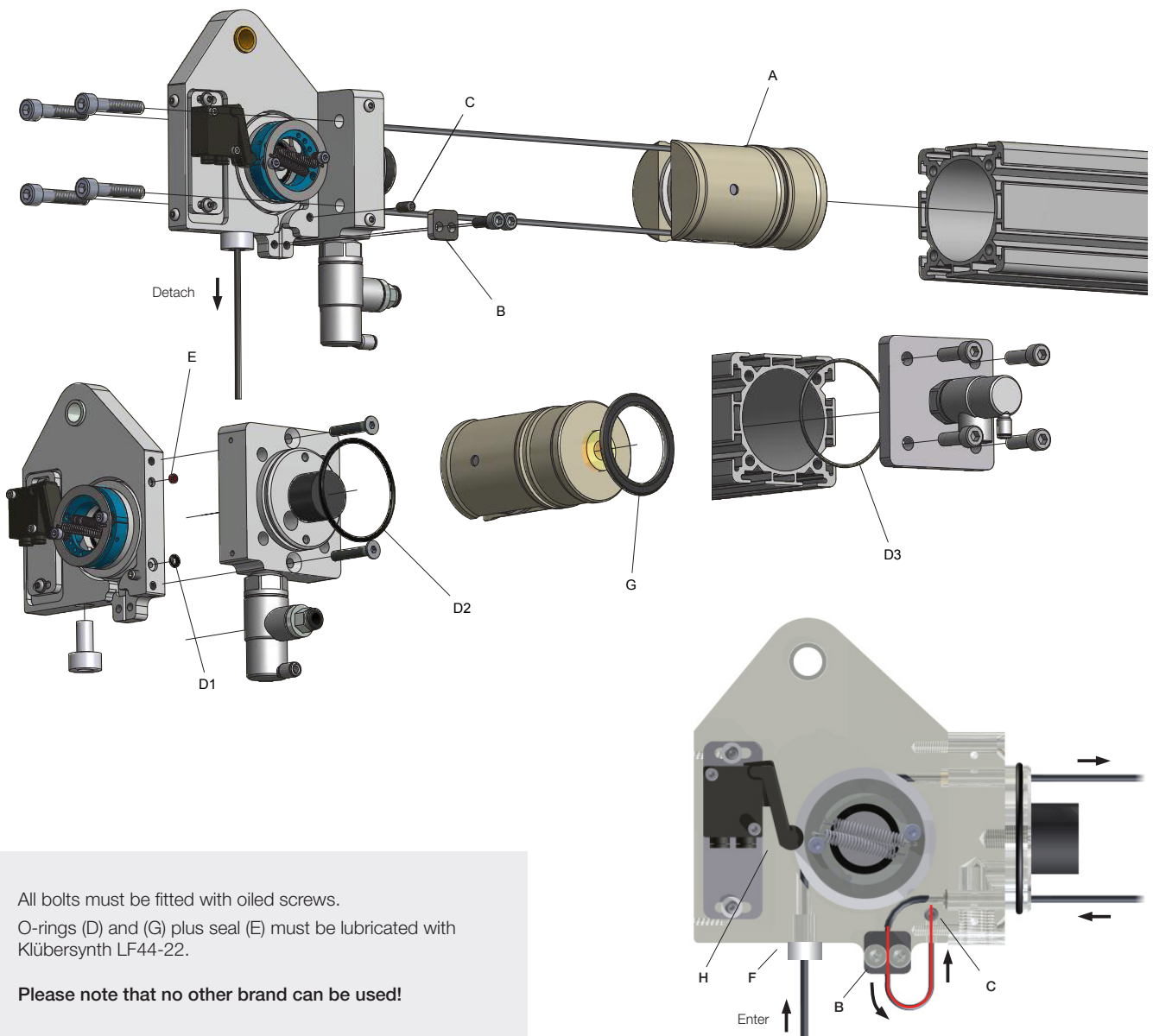

- All bolts must be fitted with oiled screws.
- O-rings (D) and (G) plus seal (E) must be lubricated with Klübersynth LF44-22.

Please note that no other brand can be used!

9.4 Shortening of build height BH

With the existing lifting wire, it is only possible to reduce the build height BH. To increase it, a longer wire is required.

1. Elevate the wire to its top position (A). Initial build height can now be measured/verified.
2. Disconnect the lifter's air supply.
3. Remove the front cover, and loosen the wire at the wire lock (B) and the stop screw (C).
4. Adjust the cable to the desired build height by pulling the free end of the wire (D).
5. When the desired height is reached, make a mark with a marker pen at the upper edge of the wire lock (E). Then pull out the cable another few centimetres.
6. Cut the cable approx. 90 mm outside the marking. Peel the wire approx. 90 mm from the end. Attach shrink tubing or equivalent

around the end (yellow marking), flex the wire end into the fastening hole and fix it with the set screw (C). Create a loop and attach the wire in the wire lock (B).

Verify that the wire is fitted correctly in the wire lock slot, and that the section of the wire that runs through the wire lock is peeled. The screws of the wire lock must be oiled and alternately tensioned with 10 Nm + 1/8 turn.

7. Remount the front end cap and reconnect the air supply to the lifter. Test the anti-jump function.

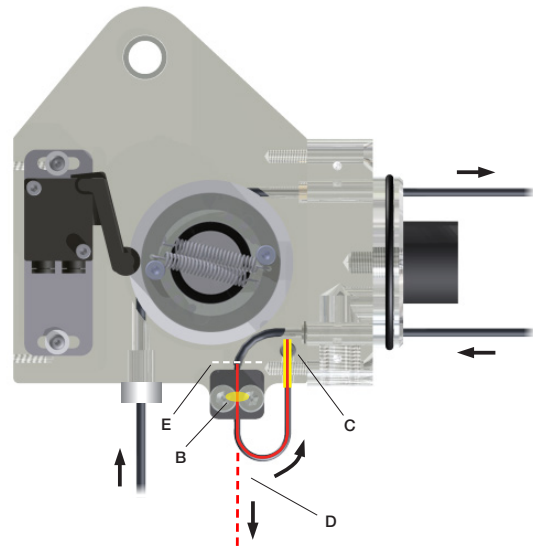
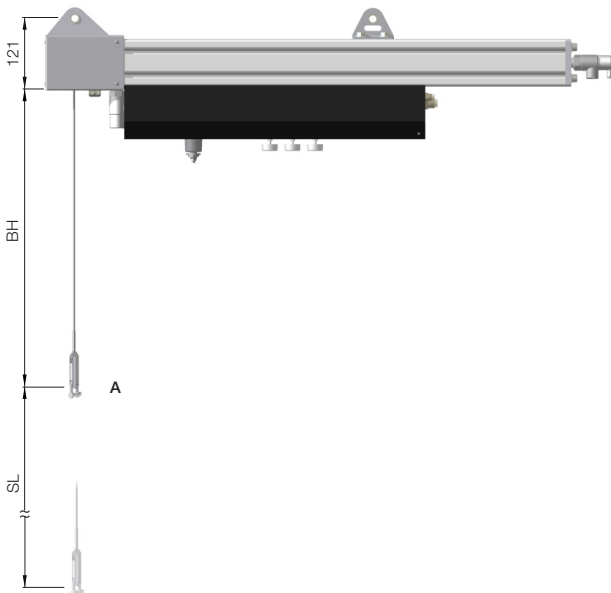

- The screws for the cable lock are normally sealed by Movomech with a color marking (B). This ensures that they upon delivery are tensioned in accordance with paragraph 6.

9.5 Testing anti-jump function

The anti-jump function locks the wire movement when the load is lifted or lowered too quickly. Its purpose is to avoid uncontrolled lifting if for example the load come loose by mistake.

The function must be regularly tested and ensured.

1. Test: pull the wire with a strong jerk, the anti-jump function will then lock the wire movement. After being locked, the wire can be released by Reset. Perform the test at least 3 times.

Funktion reiblock

2. Trigger the sensor (A) manually.

Sensoren reiblock

By the given sensor test the function again.

Sensoren ok, funktion reiblock

3. Verify that the sensor is just outside flyweights of the pulley, without being in contact (B).

Sensoren in position

Kontakt Movomech.

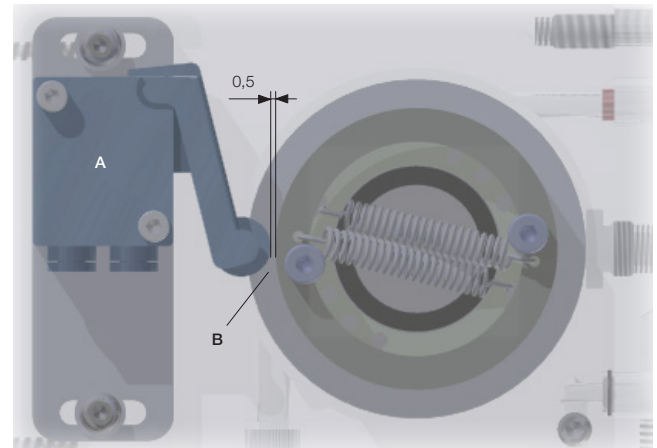

- The anti-jump function is preset to allow a lifting speed of about 0.67 m/s.
- Adjustment of the anti-jump function may be necessary when changing the handled object, or if the anti-jump function is activated during normal handling.
- If the anti-jump function is activated too often, contact Movomech.

9.6 Replacement of front pulley (complete)

If wear has occurred (pulley or ball bearing), or if the anti-jump function fails, the front pulley must be replaced.

1. Disconnect the lifter's air supply.
2. Detach the wire according section 9.3, remove the springs (A) and thereafter the screw (B) on the pulley (complete) (C). Remove the old pulley. On the back of the front end are two threaded M4 holes (D) where two M4 screws can be inserted alternately to loosen the pulley.
3. Grease the stub shaft (E) with oil and mount the new pulley. Mount the springs in the same position as on the previous pulley.
4. Remount the wire according to section 9.3. Verify that the sensor is just outside the flyweights of the pulley, without being in contact.
5. Reconnect the air supply to the lifter. Test the anti-jump function, then remount the front cover.

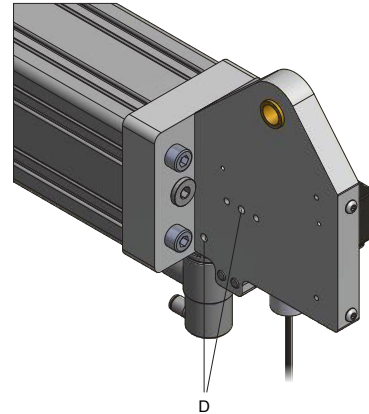
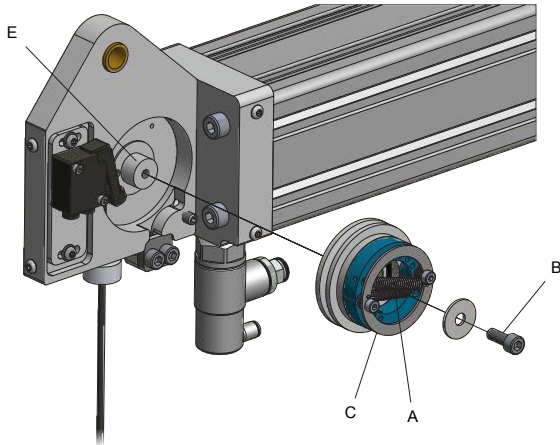

9.7 Adjustment of pressure guard 739553

If the incoming air pressure changes, or if the load falls when the air pressure is lost, it may be necessary to adjust the pressure switch.

1. Lower the air pressure level on the FRL unit with approximately 0.25 bar (e.g. from 5 to 4.75 bar).
2. Remove the pneumatic hose from port 2 on the pressure guard.
3. Carefully adjust the pressure guard until it closes, i.e. until it no longer lets any air through at port 2.
4. Secure the adjustment of the pressure guard and remount the pneumatic hose on port 2.
5. Increase the air pressure on the FRL unit with 0.25 bar to the original level.
6. Shut off the air supply and switch it on again.
7. The load should now be balanced. If not, repeat steps 1-6 but lower the air pressure with 0.5 bar instead, etc.

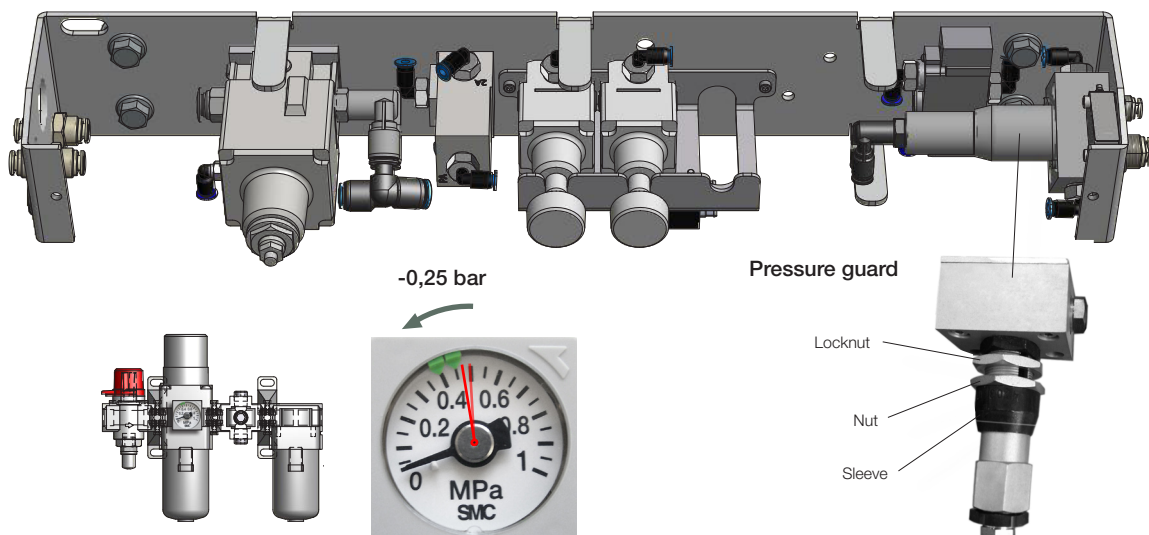

9.8 Troubleshooting

| Type of problem | Probable cause | Action |
|--|--|--|
| No hoisting motion up/down | Air supply is turned off | Check whether the air supply for some reason has been turned off, and make sure no risk of injury appears when restoration of the air supply. Some procedures may only be performed by authorized maintenance staff. Restore the air supply. No more than 5 bar. |
| | Clogged filter | Clean or replace filter. |
| | The hoist is exposed to mechanical obstacle | Check whether some part of the hoist or tool including any object, are stuck in other equipment. Remove mechanical obstacle. |
| | Defective control unit* | Check whether the hoist is supplied with air. Inspect the control unit. Some procedure may be performed by authorized maintenance staff. Repair control unit. |
| | Defective equipment* that serve as condition | Check whether external equipment serving as conditions are defect. Repair equipment. |
| Incorrect operating range | Equipment* serving as vertical working range limit out of position | Check whether stroke limiter is out of position. Reset to correct position. |
| Irregular or jerky hoisting motion up/down | The hoist is exposed to mechanical obstacle | Check whether some part of the hoist or tool including any object, are stuck in other equipment. Remove mechanical obstacle. |
| | Dirty filter | Clean or replace filter. |
| Load ascends/descends | Regulator(s) are inaccurate | Adjust setting. |
| | Air leakage | Seal leakage. |
| The load drops when air supply is shut off | Pressure guard* is inaccurate or defect | Adjust setting or replace. |

* If applicable.

10. EC certificate

CE EC declaration of conformity of the machinery

TRANSLATION
(according to 2006/42/EC, annex 2A)

Manufacturer

Movomech AB
Box 9083
S-291 09 Kristianstad
Sweden

Tel: +46 (0)44 28 29 00
Fax: +46 (0)44 28 29 28
E-mail: info@movomech.se
Web: www.movomech.com

Representative for documentation

Arne Ask
Movomech AB

hereby declares that the machinery

Designation

Mechlight Pro

Machine type

Lifting unit

Version

50

complies to all applicable regulations in

- Machinery Directive 2006/42/EC
- EMC Directive 2004/108/EC

and that standards and/or technical specifications as described below are applied.

- Machinery Directive
SS-EN-ISO 12100:2010
- EMC Directive
- Low Voltage Directive

Place: Kristianstad

Date: 2014-01-01

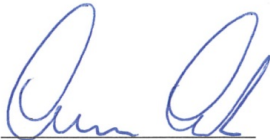

Arne Ask, CEO
Movomech AB



11. Revision list

| Revision list | | | |
|---------------|----|---|------------------------------------|
| Edition | # | Designation | Pages |
| 2012-06-20 | 0 | First edition. | - |
| 2012-12-01 | 1 | Updated pneumatic drawing AFC. | 17 |
| 2013-02-20 | 2 | Updated sealing 738851, updated instruction for anti-jump. | 20, 23 |
| 2013-07-01 | 3 | New pneumatic drawing 2-weight, 3-weight. New springs on front wheel and new swivel. Stainless version and pneumatic version AFC are discontinued as standard. Updated equation for wire length. Updated safety text and clarified definition of working cycle. Hose as spare part. New chapters: User instruction + Installation instruction. | 15, 16 - 8, 10 20, 21, 23 |
| 2014-03-01 | 4 | Pneumatic versions with slow speed function and load guard for direct control pneumatics. FRL becomes optional. Length measure corrected (360 mm). Company name updated. | 17, 19, 21 11, 36 |
| 2014-09-01 | 5 | Corrected filtration rate (due to removed FRL unit). | 10 |
| 2014-12-01 | 6 | Updated pneumatic drawings, new hose labeling. | 16-21 |
| 2015-02-01 | 7 | New standard build height BH: 1500 (was 500). Service kit as spare part. Corrected article number shackle. Updated article number FRL unit, added push-in sleeve 12-8. Revision list. | 11, 28 12, 13, 28 5 |
| 2015-04-01 | 8 | New version of wire guiding and pulley housing. (Cover and front end revised.) Updated article number seal. Corrected article number FRL. | 14 22 |
| 2016-02-01 | 9 | Rear end o ring added in base model. Updated pneumatic drawings. New option: load limiting kit. Updated layout. Added <i>Service kit</i> to spare part list. | 9, 13-25, 26, 32 35 |
| 2016-12-01 | 10 | Changed recommended FRL unit/filtration rate. | 7, 28 |



LIFT-O-FLEX

MOBI-Crane

Voyager

+1.704.847.2464
+1.866.843.8635

info@roni.com
www.roni.com

8001 Tower Point Drive
Charlotte, NC 28227

Copyright © 2016 R on I, Inc.
Document ID 70006 Rev. 161219

R on I reserves the right to change this information without further notice and holds no liability for printing errors in this content.