



PLACE  
SERIAL  
NUMBER  
LABEL  
HERE

# LIFT-O-FLEX 19700 LIFTER USER MANUAL

DOCUMENT ID: 01022018

Have Questions?

We're here for you.



+1 866 543 8635  
+1 704 847 2464



info@roni.com  
www.roni.com



# LIFT-O-FLEX

MOBI-Crane |  | 



RONI  
8001 Tower Point Drive  
Charlotte, NC 28227 USA

# BEFORE YOU BEGIN



## READ

It is important that you read and understand this complete manual prior to using your LIFT-O-FLEX® ergonomic handling equipment. If you have any questions, contact your dealer or Ronl.



+1 866 543 8635  
+1 704 847 2464



info@roni.com  
www.roni.com



8001 Tower Point Drive  
Charlotte, NC 28227 USA

---

## SPECIAL NOTES

The appearance of your LIFT-O-FLEX® lifter and the accompanying attachments may differ from the images displayed in this manual due to the custom nature of this equipment.

LIFT-O-FLEX® is a registered trademark of Ronl, Charlotte, North Carolina.

“Where **Ergonomics** make  
**Economic** sense.”

# TABLE OF CONTENTS

<b>1. DESCRIPTION</b> .....	<b>4</b>
1.1 OVERVIEW	
1.2 OPTIONS	
1.3 ATTACHMENTS	
<b>2. SAFETY</b> .....	<b>5</b>
2.1 BUILT-IN SAFETY FEATURES	
2.2 STORAGE AND TRANSPORT	
2.3 MOVEMENT	
2.4 LOADING AND UNLOADING	
<b>3. WARRANTY</b> .....	<b>6</b>
<b>4. ASSEMBLY INSTRUCTIONS</b> .....	<b>8</b>
4.1 ASSEMBLY	
4.2 DISASSEMBLY	
<b>5. OPERATING INSTRUCTIONS</b> .....	<b>11</b>
5.1 USING THE LIFTER	
5.2 ADJUSTING THE HANDLEBAR	
5.3 POWER PACK	
5.4 REMOTE CONTROL	
5.5 BRAKE SYSTEM	
<b>6. MAINTENANCE</b> .....	<b>13</b>
6.1 GUIDELINES	
6.2 EVERYDAY	
6.3 EVERY YEAR, OR WHEN NEEDED	
<b>7. TROUBLESHOOTING</b> .....	<b>16</b>
<b>8. TECHNICAL SPECIFICATIONS</b> .....	<b>17</b>
<b>9. SCHEMATICS</b> .....	<b>18</b>
9.1 WIRING DIAGRAM	
9.2 SPARE PARTS	
<b>10. DECLARATION OF CONFORMITY</b> .....	<b>22</b>



# 1. DESCRIPTION

## 1.1 OVERVIEW

LIFT-O-FLEX® lifters are ergonomically designed to simplify handling, lifting, and transportation of goods. Each lifting unit can be equipped with different types of load carriers or attachments. The goods to be handled are placed on the load carrier and adjusted to the desired height by pressing the buttons on the hand-held remote control pendant. The lifter is powered by rechargeable, sealed, lead acid batteries. The lift mast is totally enclosed and features a ball screw for smooth vertical DC-powered movement.

## 1.2 OPTIONS

The LIFT-O-FLEX comes standard with a Powder-Coated Paint/Anodized finish. As an additional option, the LIFT-O-FLEX is also available in Stainless Steel/Anodized finish.

An additional electronic power pack with quick exchange features is available to allow for multishift use.

## 1.3 ATTACHMENTS

Standard attachments for the LIFT-O-FLEX include a load platform, with or without a stationary or rotating V-Block, a fixed core probe, an Expand-O-Turn, and Squeeze-O-Turn. Custom applications are also available upon request.



← Platform with V-Block



Core Probe →



← Expand-O-Turn



Squeeze-O-Turn →

## 2. SAFETY

### 2.1 BUILT-IN FEATURES

The ergonomic design of the LIFT-O-FLEX is, in itself, an active factor of operational safety. The rear casters are equipped with pedal-activated brakes and the handle bar adjusts vertically to provide optimal ergonomic positioning for the operator. The lift mast contains a slip clutch; if anything gets in the way of the downward movement of the attachment, the slip clutch engages to help prevent injuries as well as mechanical damage to the lifter. We have also incorporated current limiting to prevent overloading beyond the rated capacity for the unit.

### 2.2 STORAGE AND TRANSPORT

During storage and transport, the remote control pendant and motor cable should be disconnected. The lifter should be secured during transport to avoid the risk of tipping over.

### 2.3 MOVEMENT

The load carrier should always be lowered as low as possible to ensure safe and stable handling. Use caution when passing thresholds, cords, and other objects on the floor. The handle bar should be gripped in a way so that the hands are not hurt when passing edges, walls, or protruding objects. The movement of heavy loads can be easier when using the directional lock (details listed under *5.5 Brake System*).

### 2.4 LOADING AND UNLOADING

The user is responsible for ensuring that the lifter is loaded correctly.

Always apply the brakes when loading and unloading.

The center of gravity of the goods should always be centered on the load carrier and positioned as close to the lift mast as possible for maximum stability.

The load carrier should be positioned at the correct height before loading and unloading to allow a good working position. The load should be pushed or pulled on or off of the load carrier.



# 3. WARRANTY

## Limited Warranty

Ronl warrants this product to be free of defects in material and workmanship during the warranty period. Our warranty obligation is to provide a replacement for a defective original part if the part is covered by the warranty, after we receive a proper request from the warrantee (you) for warranty service.

### Who may request service?

Only a warrantee may request service. You are the warrantee if you purchased the product from Ronl or from an authorized distributor and Ronl has been fully paid.

### What is an “original part”?

An original part is a part used to make the product as shipped to the warrantee.

### What is a “proper request”?

A request for warranty service is proper if Ronl receives: 1) a photocopy of the customer invoice that displays the shipping date and 2) a written request for warranty service that includes your name and phone number. Requests may be sent using the following methods:

#### Mail

Ronl  
8001 Tower Point Drive  
Charlotte, NC 28227

#### Fax

Toll Free 1-866-543-9532  
Direct 1-704-847-6739

#### Email

info@roni.com

### What is covered under the warranty?

After Ronl receives your request for warranty service, an authorized representative will contact you to determine whether your claim is covered by the warranty. Before providing warranty service, Ronl may require you to send the entire product, or just the defective part(s), to its facility in Charlotte, North Carolina.

### How long is the warranty period?

The warranty period for original dynamic components is one (1) year. For batteries, the warranty period is 30 days. The warranty period begins on the date when Ronl ships the product to the warrantee.



## Warranty Evaluation

All parts sent back (freight paid by customer) to Ronl for warranty replacement and/or repair will be evaluated. Ronl will determine if the part is a warranty issue or if it has been damaged due to misuse or negligence. A written report will be issued detailing the investigation of the part and whether or not the part is classified as warranty.

### What is not covered by this warranty?

1. Labor
2. Freight
3. Occurrence of any of the following, which will automatically void the warranty:
  - product misuse
  - negligent operation or repair
  - corrosion or use in corrosive environments
  - inadequate or improper maintenance
  - damage sustained during shipping
  - collisions or other incidental contacts causing damage to the product
  - unauthorized modifications: do not modify the product in any way without first receiving written authorization from Ronl as modifications(s) might make the product unsafe to use or could potentially cause excessive and/or abnormal wear

### If a defective part is warranted, how will Ronl correct the problem?

Ronl, will provide an appropriate replacement for any covered part. An authorized representative of Ronl will contact you to discuss your claim.

### Warranty Procedure

In the event that a part is damaged or broken, please contact Ronl via phone or email to establish a dialogue to identify and diagnose the problem. Please have your lifter serial number available when you call or email.  
(located on the motor cover underneath the intermediate)

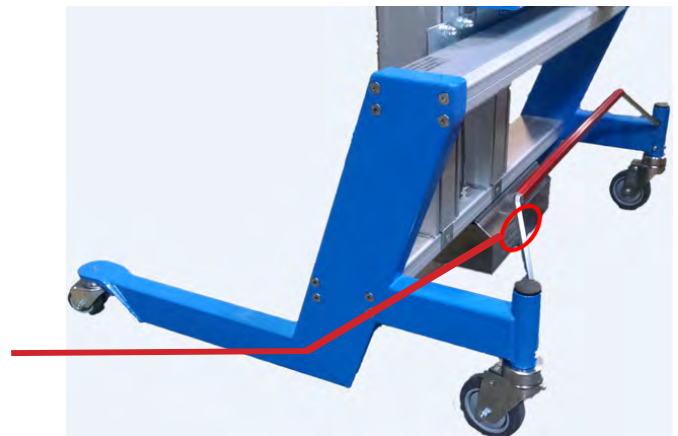

# 4. ASSEMBLY INSTRUCTIONS

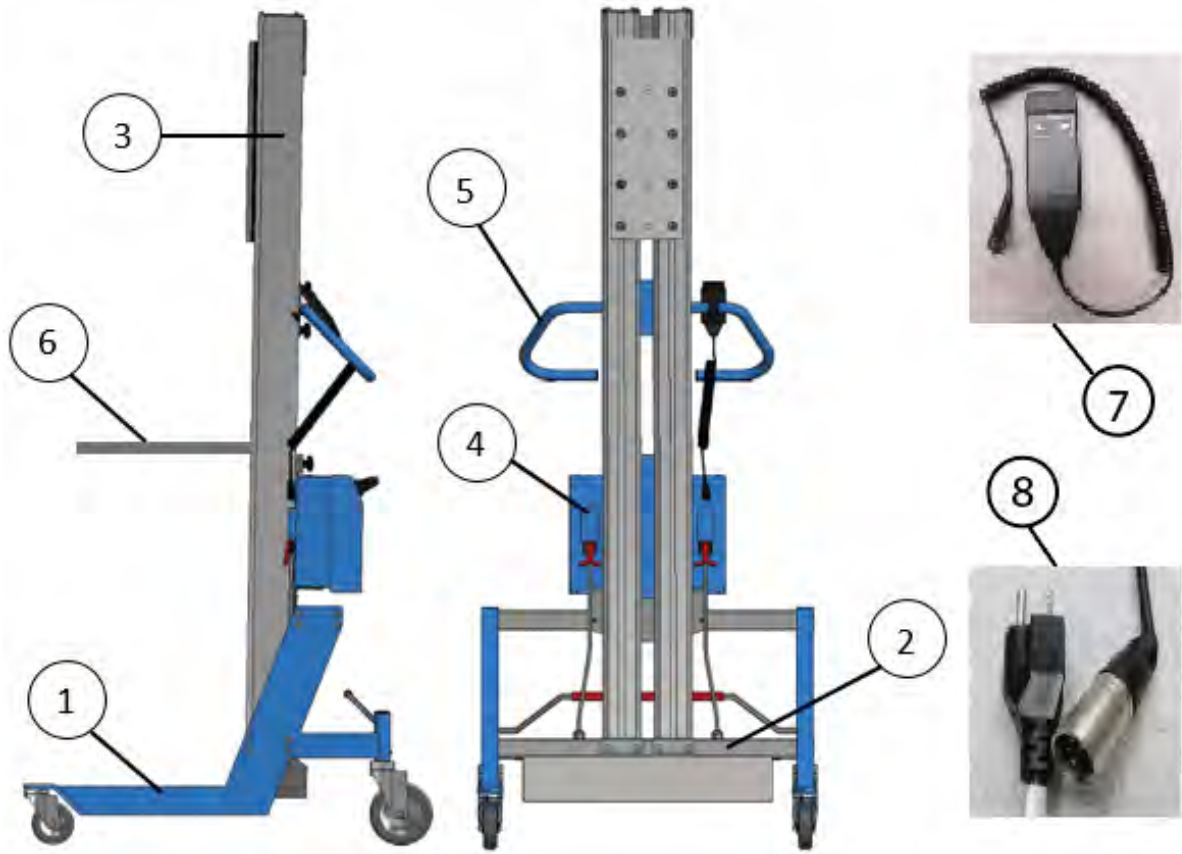

*The wheel frame and the cross-member are integrated on some models:*

- |                  |                |                |
|------------------|----------------|----------------|
| ① Lifter leg     | ② Intermediate | ③ Lift mast    |
| ④ Power pack     | ⑤ Handlebar    | ⑥ End-effector |
| ⑦ Remote control | ⑧ Charger      |                |



## 4.1 ASSEMBLY

### Assembly Instructions

The lifter is normally delivered disassembled in modules or partially assembled in order to minimize freight costs. When the lifter is delivered disassembled, each module comes separate with required screws and tools, etc. When the lifting device is delivered partially assembled, the frame will be together and the components such as masts, power pack and handle will need to be mounted to the frame.

#### ASSEMBLING THE FRAME

[\(Associated diagrams on the next page\)](#)

- 1) Place the wheel frame and cross-member on the floor and activate the wheel brakes.
- 2) Slide the columns onto the bracket on the cross-member. The screw bar on the bracket fits the slots on the back of the mast.
- 3) Place the power pack on the ground next to the lifter. Connect the motor cable and the remote control to the power pack.
- 4) Press the up button on the remote control to make the masts go down to its lowest position. The mast should stand directly on the cross-member. Tighten the 6 screws at the bottom. Disconnect the power pack.
- 5) Fit the lower and the upper bracket for the power pack into the two middle slots on the back of the masts. Move it downwards until it stops.
- 6) Fit the handlebar into the slot on the back of the mast and lock it so that the power pack will fit underneath. Don't tightened too hard.
- 7) Fit the bracket into the slot on the back of the mast. Position it in the top end of the columns tightening the nuts by hand.
- 8) Slightly tighten the lower bracket for the power pack. Fit the power pack on the lower bracket and lock it with the upper bracket by tightened the black knob. Plug the motor cable contact into the matching socket on the power pack. Connect the remote control and place it on the handlebar.



- 9) By pressing down on the remote control, move the slides to the lowest position and mount the bracket for the attachment joining the two slides.
- 10) Move the slides with the bracket by pressing up on the remote control. Stop in the middle of the mastss.
- 11) Tighten the nuts on the back of the cross-member, power pack bracket and the top bracket (18 nuts) but not too hard, with a 13-mm wrench.
- 12) Attach the end effector with the supplied screws and washers in the slide of the mast.
- 13) Perform a static load test, with 1.25 x the maximum load.  
(Move the attachment to the middle of the mast and apply the load.)
- 14) The lifter is now ready to use.

## BRAKE ROD POSITIONS

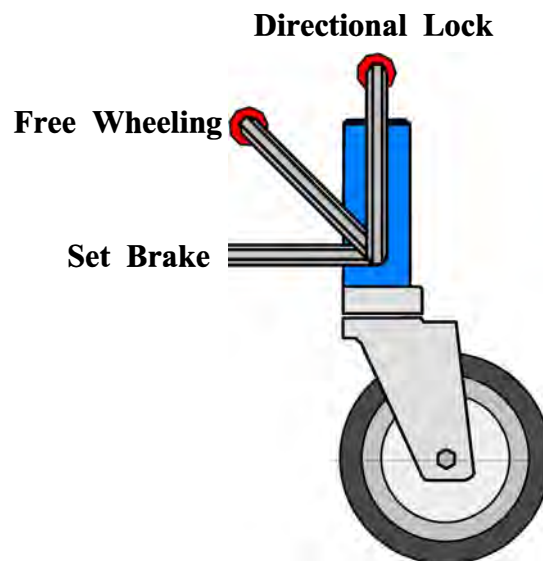

## 4.2 DISASSEMBLY

To disassemble the lifter, refer to directions above and reverse the order.

### **Disposal after useful life**

When the lifter has provided many years of use and is ready to be disposed of, it should be recycled. The LIFT-O-FLEX® lifter is manufactured with materials that are recyclable. We have also selected recyclable gel-cell batteries over nickel-cadmium batteries for this purpose.

# 5. OPERATING INSTRUCTIONS

## 5.1 USING THE LIFTER

In order to prevent and avoid work injuries, it is important that the LIFT-O-FLEX is operated in a proper manner.

Please note, if a load remains on the lifter for some time, it may be necessary to lower the load before it can be raised.

## 5.2 ADJUSTING THE HANDLEBAR

The height of the handlebar can easily be adjusted by loosening the quick disconnect knobs and sliding the handlebar to the desired position. After adjustment, tighten the quick disconnect knobs. To obtain the best working conditions, it is important to adjust the handle to a comfortable level. During movement of the lifter, always keep your hands inside the handlebar. This will protect the hands in the event the handlebar should encounter an obstacle. Never put arms through the handlebar to reach something on the load carrier, as this may pose a crush hazard.

## 5.3 POWER PACK

Modifying the power pack is dangerous. This device may not be sealed in any way. It should not be exposed to splashed or running water.



## 5.4 REMOTE CONTROL

The load carrier is raised and lowered by pressing the buttons on the hand-held remote control pendant. The remote control has either two or four buttons and is used as shown below.



The remote control should be placed to allow the user to easily press the buttons. The bracket for the remote control is fitted to the handlebar. The bracket can easily be moved by turning the black knob counter-clockwise. The bracket can be locked in any position on the handle by turning the knob clockwise. The bracket can be tilted to any angle on the handlebar. The remote control can be removed from the bracket.

## 5.5 BRAKE SYSTEM

On lifters equipped with a central brake, the brake is applied by moving the brake bar to its lowest position.

On lifters equipped with a central brake, the directional lock is activated by moving the brake bar to its highest position. This locks the rear wheels in a position that only allows the lifter to move straight forward or backward.

On lifters with individually-braked wheels, the brakes are applied by pressing down the lever on each wheel separately.



# 6. MAINTENANCE

## 6.1 GUIDELINES

In order for the lifter to function properly, it is important that maintenance is carried out in accordance with what is described below. The stated service intervals are applicable during normal use and charging once a day. Further use requires more frequent service intervals. After disassembly or assembly of the mast or load carrier, a load test should be performed.

## 6.2 EVERYDAY

### Charging

Only chargers supplied or approved by Ronl may be used.

The charger must not be exposed to water.

The lifter must be in a well-ventilated area when it is being charged.

Always connect the charger to the lifter before connecting to the main power.

Do not operate the device while charging.

The batteries should be recharged every night. In order to avoid complete discharge, which damages the batteries, the batteries should also be charged when the lifter is not used for an extended period of time, e.g. during weekends and holidays.

When the battery charger is connected to the lifter and has power, there is a yellow/orange light on the charger, indicating ongoing charging. When the batteries are fully charged the light is green. The lifter can remain connected to the charger indefinitely without risk of overcharging, preferably until next use.

For lifters with a power pack equipped with a voltage indicator, a flashing bar on the voltage indicator means that the batteries need charging. If the lifter is left unused for 10 minutes, sleep mode is activated and the voltage indicator turns black. The lifter can be restarted by pressing any button on the remote control. When the lifter is restarted from sleep mode after charging, it takes two minutes before the voltage indicator shows if the batteries are fully charged.



## 6.3 EVERY YEAR, OR WHEN NEEDED

### Cleaning

Clean the lifter by wiping it down only. Wipe the lifter dry after cleaning. Do not use hose or high-pressure jet as this may damage the electronics and the paint.

### Electrical connections

Check all connections and repair any damage or wear. If needed, replace with new parts.

### Wear of machine parts

Check the parts of the machine in order to identify any cracking or wear.

### Nuts and bolts

Make sure all nuts and bolts are tightened.

### Lift mast

Lift the mast from the cross-member.

Clean the brush strips and wipe the mast clean.

Remove the four corner screws at the top of the mast (not the three in the middle).

Pull out, wipe and lubricate the lift screw with new ball bearing grease.

Put the lift screw back and tighten the screws.

Check the coupling by making sure the sleeve and the hub located inside the mast and inside the cross-member are intact and in working order.

Put the lift mast back and perform a load test.

### Wheels

Make sure all wheels run smoothly.

Lubricate the bearings.

Check that the tire rubber is intact.

### Brakes

Check that the brakes work.

### Knobs for handlebar and bracket for remote control

Check that the knobs loosen and tighten correctly.



## Replacing the fuse

The fuse is located inside the power pack. A wiring diagram for the lifter is attached to the inside of the lid of the power pack. Before removing the lid, by loosening the screws, the user should apply the brakes and wear protective footwear. Be extra cautious when opening the power pack. If the device is tilted after the lid has been removed, the batteries can slide out of the power pack and harm the user.

## Replacing the batteries

Batteries may be replaced by a person with basic technical knowledge. When changing the batteries, protective footwear should be used and the brakes should be applied. To open the power pack, see section above. Used batteries should be handed in to a recycling center.

## Plates and decals

Verify that the following plates and decals are attached and fully readable.

Plate / Decal	Description	Placement
<b>CE Decal</b>	Decal with CE mark and year of manufacture	At the back of the intermediate
<b>Serial Number</b>	Decal with serial number	At the back of the intermediate & at the bottom on one side of the lift mast
<b>Model</b>	Decal with text stating the model of the lifter	At the back of the lift mast
<b>Maximum Load</b>	Decal with text stating the maximum load and that lifting people is not allowed	At the top on both the left and right sides of the lift mast
<b>Do Not Step, Do Not Stand Under Platform, Charge @ Night</b>	Decal with Do Not Step, Do Not Stand Under Platform, Charge @ Night	On the top right of the intermediate
<b>Moving / Unloading</b>	Decal with moving and unloading instruction	On the top left of the intermediate
<b>Brake Positions</b>	Decal with brake positions	At the back of the power pack
<b>Safety Information</b>	Card with warranty check list and contact information	Zip tied to handlebar



# 7. TROUBLESHOOTING

The lifter is designed for safe and efficient operation, provided that routine maintenance is carried out in accordance with the instructions given. If problems arise, some guidance is provided below. If the problem persists after action has been taken, please contact a service technician or Ronl.

## **If the load carrier does not move or moves very slowly:**

- Verify that the maximum load is not exceeded.
- Charge the batteries.
- Check that the battery charger works. A light should be visible on the charger when plugged into the main power.
- Check if the fuse inside the power pack needs to be replaced.
- Check the battery voltage and replace the batteries if the voltage after eight hours of charging is less than 24 volts.

## **If the lifter sounds strange:**

- Make sure the lifter is correctly assembled, see section Assembly.
- See section Maintenance.



# 8. TECHNICAL SPECIFICATIONS

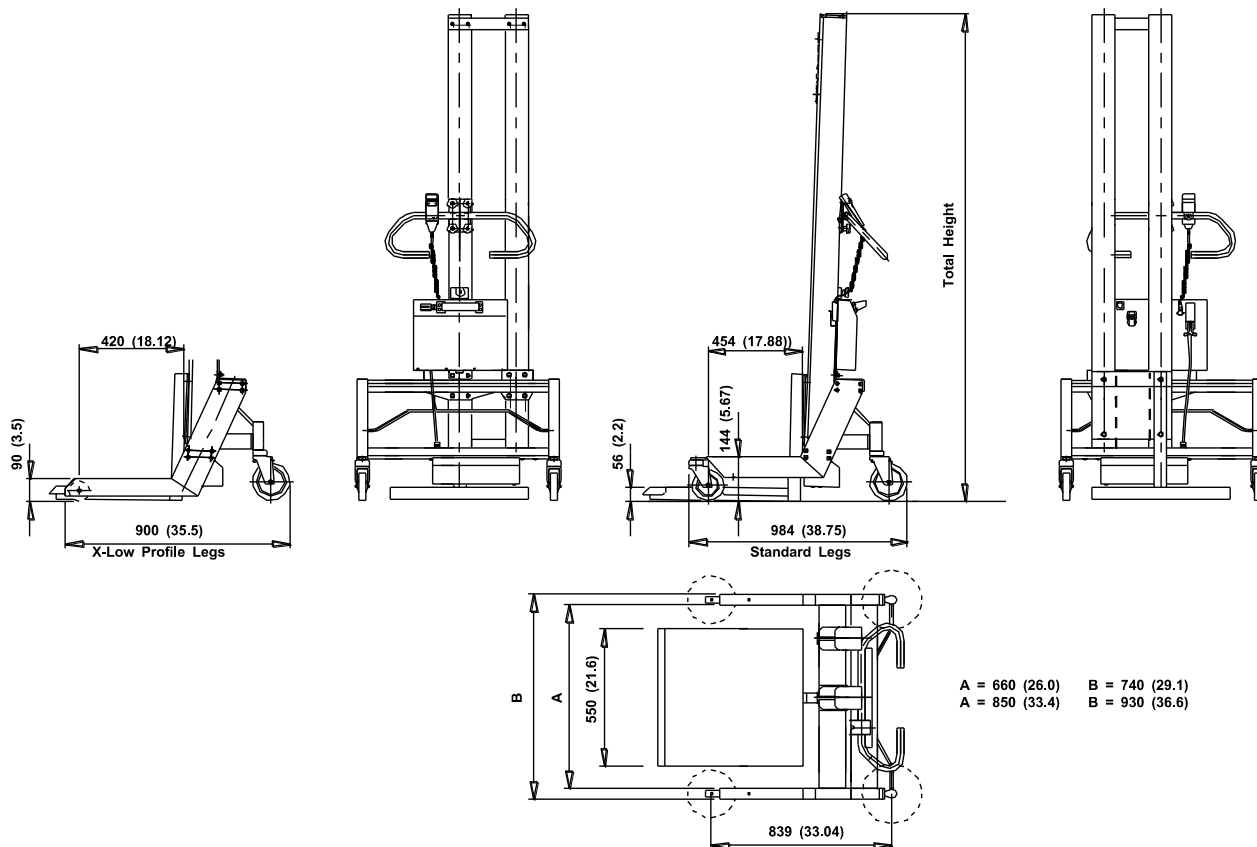

**NOTE: Custom Lift-O-Flex® solutions can be designed specifically for your application**

Technical Specifications 19800 (Dual Drive Mast) Series	
Floor to top of Mast	Total Lift Stroke
21021mm (82.7")	1262mm (49.7")
2603mm (96.5")	1694mm (66.7")
3106mm (116.2")	2260mm (89")
Minimum Lift Height	~56mm (~2.2")
Lift-Speed 19800 Series	~50mm/sec (2"/sec)
Legs-Standard (Overall Length)	Std Length 984mm (38.75")-Long 1184mm (46.6")-X-Long 1384mm (54.5")
Legs-X-Low Profile (Overall Length)	Std Length 900mm (35.5")-Long 1110mm (39.7")
Wheel Material	Polyurethane/Rubber
Wheel Diameter (Front/Back) Standard	100mm (3.9")/150mm (5.9")
Wheel Diameter (Front/Back) X-Low Built	Front Fixed Castor 76mm (2.9")/150mm (5.9")
Width: Outside	Std-680mm (26.7")
Noise level	>70dB(A) 360Kg
Maximum Load	(800-lbs) ~125Kg
Lifter Weight w/o End-Effector	(280-lbs)
Battery Type	Vented Lead Cell
Battery Voltage	24V, 2 Amp
Battery Capacity	7.2 Ahr
Recharge Time	6-8 Hours
Lifter Finish	Powder Coated Paint/Anodized or Stainless Steel/Anodized



# 9. SCHEMATICS / 9.1 WIRING DIAGRAM

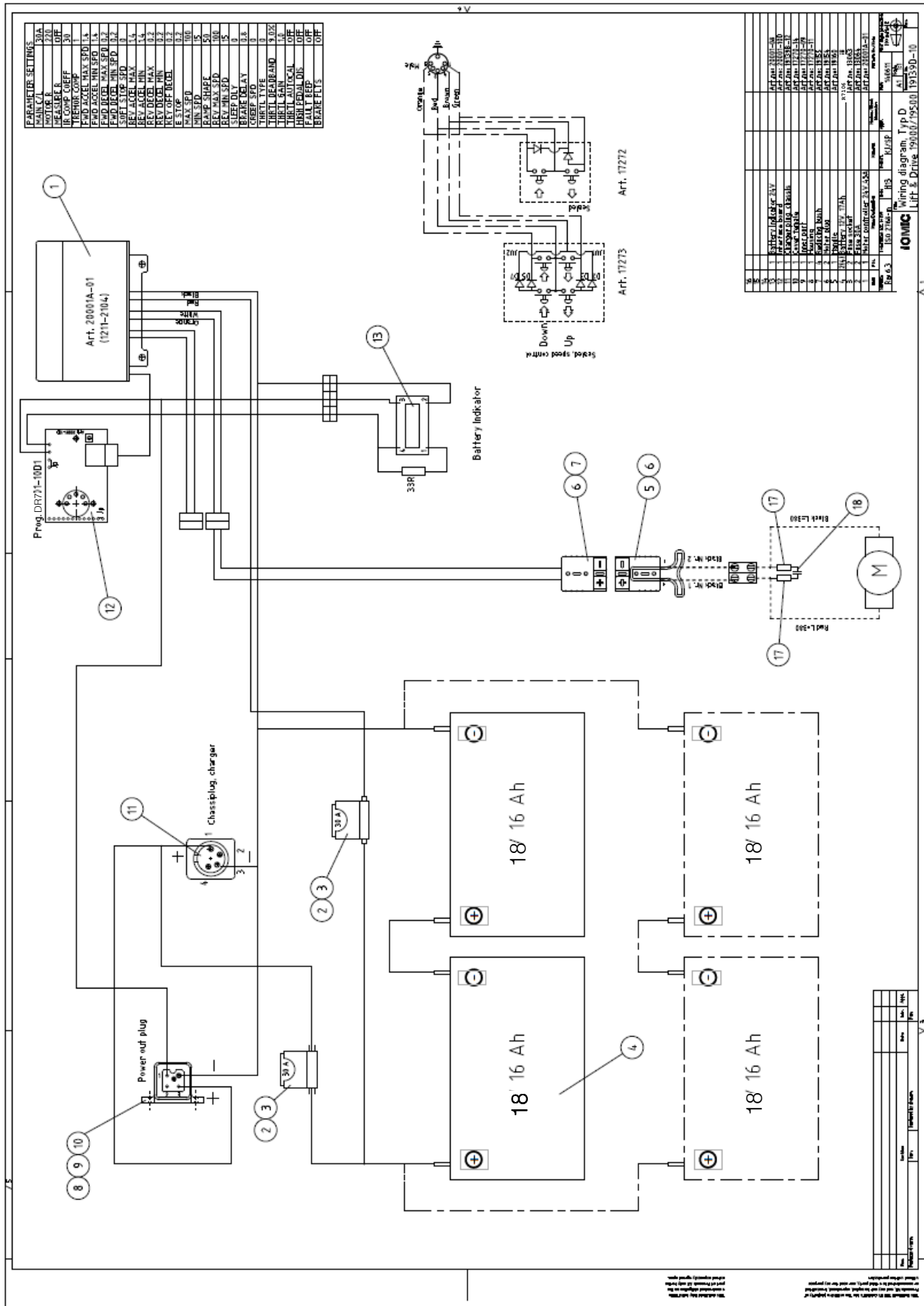

## 9.2 SPARE PARTS

Only spare parts supplied or approved by Ronl may be used.

### Commonly Ordered Spare Parts

Part Number	Description
17272	Two-button remote control
17273	Four-button remote control
2403SRL	Battery charger
R7106	Battery set
19265A	Lift motor (uses 2 motors)
40:1	Lift gear
20011-01	Low built front caster (dual swivel)
17557	Low built rear caster
20010-01	Standard front caster
19118	Standard rear caster

## Contact us to order!

1-866-LIFT-O-FLEX (543-8635)  
spareparts@roni.com

### Commonly Ordered Spare Parts



*(continued on the next page)*



## Commonly Ordered Spare Parts



2403SRL Assembly.png



R7106 Battery Set.jpg



19265A Lift Motor



19265A (2) Lift Motor

*(continued on the next page)*



40:1 Gear.jpg



40:1 Gear (2).jpg



20011-01 Replacement Casters Front Low Profile  
Dual Swivel 60 mm



17557 Standard Rear Wheel Assembly



20010-01 Replacement Caster Front Std Single  
Swivel 100 mm



19118 Replacement Rear Wheel Assembly with  
Brake 150 mm



# 10. DECLARATION OF CONFORMITY

Manufacturer	Pronomic AB Box 5504 192 05 Sollentuna Sweden
Model	LIFT-O-FLEX 19700
Serial Number	
Static load test	

Authorized to compile the technical file	Samuel Pierre, Pronomic AB, BOX 5504, 192 05 Sollentuna, Sweden
--	---

Applied EC directives:

2006/42/EC	Machinery Directive
2004/108/EC	EMC Directive

Applied standards:

SS-EN ISO 12100:2010	Safety of machinery - General principles for design - Risk assessment and risk reduction (ISO 12100:2010)
SS-EN 349+A1:2008	Safety of machinery - Minimum gaps to avoid crushing of parts of the human body

We hereby declare that the above-referenced machine, built and equipped with attachments included in this manual, is in conformity with the applicable conditions state in the directives and standards.

Sollentuna, 2015-12-07



.....

Joakim Stannow, Pronomic AB

The lifter has been modified and/or equipped with attachments as follows:

.....

.....

After modification a supplementary risk analysis has been performed and the machine is certified to be in conformity with the directives and standards above.

.....

Place, date

# NOTES



[info@roni.com](mailto:info@roni.com)



[www.roni.com](http://www.roni.com)



+1 866 543 8635  
+1 704 847 2464



8001 Tower Point Drive  
Charlotte, NC 28227 USA



# LIFT-O-FLEX

MOBI-Crane | *inovomech* | Voyager

## **RONI**

8001 Tower Point Drive  
Charlotte, NC 28227  
USA

+1 866 543 8635  
info@roni.com  
www.roni.com

R on I reserves the right to change this information without further notice and holds no liability for printing errors in this content.

Copyright © 2016 R on I, All Rights Reserved.