

MECHCHAIN PRO II

63/80/125/225

EN
CE



LIFT-O-FLEX

MOBI-Crane  Voyager

Although the greatest care was taken regarding the information in this catalogue, we assume no responsibility for any errors. We reserve the right to make changes.

The illustrations in the catalogue represent the described products, but the delivered goods may differ in some respects from the illustrations.

The right is reserved to make changes in design and dimensions compared with the information in the catalogue in order not to prevent development of designs, material and manufacturing methods.

The customer is reminded that in the purchase of Movomech's products for application on the job or elsewhere, there is supplementary, current information that could not be included in the catalogue in terms of recommendations on each product's suitability regarding different combinations of Movomech's comprehensive product line.

All relevant information must be provided to the persons who are responsible for the application of the product.

Table of contents

1.	Safety	4
2.	Technical data.....	6
2.1	Properties and performance.....	6
2.2	Overview	7
3.	Sub-assemblies	8
3.1	Base models.....	8
3.2	Configurations.....	14
4.	Control units	16
4.1	Combinations with standard cable	16
4.2	Combinations with spiral cable and integrated emergency stop	18
4.3	Combinations with spiral cable and separate emergency stop.....	20
4.4	Remote control	22
5.	Accessories	23
5.1	Encoder	23
5.2	Brackets for control units	24
5.3	Balancer for cable	25
5.4	Spiral hose with bracket.....	25
6.	Circuit diagram and parameter settings.....	26
6.1	Circuit diagram Mechchain Pro II.....	26
6.2	Electrical cabinet	27
6.3	Circuit diagram Mechchain Pro II with encoder.....	28
6.4	Circuit diagram Mechchain Pro II with remote control	29
6.5	Circuit diagram control units.....	30
6.6	Parameter settings 63 - 80 - 125 - 225 kg	31
7.	Installation and commissioning.....	32
7.1	Mechanical installation	32
7.2	Electrical installation	32
7.3	Frequency inverter – using the front panel keypad.....	33
7.4	Setting of encoder (option)	37
8.	User instructions	38
9.	Service, maintenance & running	39
9.1	Recommended spare parts / wear parts	40
9.2	Service record — Mechchain Pro II	41
9.3	Chain and chain sprocket.....	42
9.4	Replacement of chain	43
9.5	Check of hook wear	44
9.6	Adjustment of spindle limit switch.....	45
9.7	Troubleshooting.....	46
9.8	Trip history and inverter status.....	47
10.	EC certificate	49
11.	Revisions	50

1. Safety

Movomech's equipment is manufactured in accordance with the latest technological advances, and according to the latest applicable European standards and directions. The aim of this documentation is to provide the user with practical instructions for safe operation and simple maintenance of the equipment.

Anyone who deals with the installation of the equipment (including related equipment), operational procedure, use, maintenance, and/or repair functions must have read and understood:

- the instruction manual,
- the safety regulations, and
- the safety instructions for each individual section.

In order to avoid misuse and to ensure the reliable operation of the products, we recommend that the instruction manual is always available to the user/operator.

Intended usage

The equipment is intended exclusively for transportation, lifting and lowering of load. Any other use, including the towing of a load and the transportation of passengers, is prohibited (see below for more examples). RonI does not accept responsibility for damage caused by such use. All risks are the sole responsibility of the user.

The equipment may only be used in perfect technical condition by trained staff, and in accordance with current safety and work protection regulations. Furthermore, the user must observe operational and maintenance conditions contained in the instruction manual. Severe personal injury and damage to equipment can be caused by:

- removal of covers and casings,
- non-professional installation of equipment,
- incorrect usage, or
- insufficient maintenance.

Prohibited usage

Certain types of activities and operations are prohibited, as in specific circumstances they can cause personal injury as well as permanent damage to the construction. For example:

- It is prohibited to convey passengers using the equipment.
- Never transport suspended loads above anyone's head.
- Never drop a suspended load, and make sure it is lifted in a straight line.
- Never loosen secured or fastened loads by using the equipment.
- Do not overload.
- Do not leave a suspended load unattended.

General safety aspects

The instruction manual should always be kept within easy reach of the equipment. It contains important safety information and sections that relate to guidelines, norms, and regulations. Failure to follow the safety regulations in this instruction manual may result in personal injury or death.

In addition to the instruction manual, generally applicable regulations and rules must be followed and adhered to in order to avoid accidents and protect the environment. This also applies to regulations relating to the handling of products dangerous to the environment and the use of personal safety equipment.

As regards all work associated directly or indirectly with the equipment, the user must follow and adhere to all the above regulations as well as current work protection and safety regulations. In spite of this, a life-threatening risk still prevails in cases where the equipment is used and operated by non-trained or non-instructed staff in a non-professional or non-intended way.

The user should supplement the instruction manual with instructions that consider the nature of the operation, e.g. company organisation, work procedures, and number of staff.

The members of staff who are assigned to work with the equipment must have read the instruction manual prior to undertaking any work, and he/she should pay particular attention to the chapters containing safety instructions. It is too late once work has commenced. This applies in particular to members of staff who are working with the equipment on a temporary basis, e.g. for maintenance purposes.

When convenient, the staff should be tested on their knowledge of the manual's contents that relate to safety and accident awareness.

The user is responsible for ensuring that the equipment is used only when it is in perfect condition and that all applicable and relevant safety regulations and requirements are followed.

The equipment should be taken out of operation immediately if functional damage or defects are discovered.

Personal safety equipment should be used as and when necessary, or when required by regulations.

Safety and warning devices, such as signs, stickers and labels must not be removed or made illegible.

All safety and warning devices on or adjacent to the equipment should be complete and maintained in a legible/functional condition.

All changes, extensions or reconstruction that may affect safety are forbidden without written permission from RonI. This also applies to assembly and adjustment of safety equipment and welding of structural parts.

Spare parts must comply with Movomech's stated technical requirements. This compliance is guaranteed when original spare parts are used. The intervals prescribed or stated in the instruction manual for regular testing/inspection must be adhered to!

Staff selection and qualifications

Reliable staff must carry out work with/on the equipment. Regulations that apply to under-age persons must be followed.

The user is responsible for supplying necessary training and instructions to those that he/she employs, including professionals and/or apprentices.

It is recommended that the user draws up instructions and guidelines relating to the causes of errors, communicates these to the relevant staff, and posts directions on appropriate and clearly visible places.

It is recommended that the user makes sure that the knowledge of the staff is adequate as regards the following points, prior to the operation of the construction:

- knowledge of the contents of the instruction manual,
- knowledge of the safety and user regulations contained therein,
- and knowledge of applicable work protection regulations.

Only trained and instructed staff should be permitted to work with the equipment. Parameters relating to use, maintenance, and installation should be clarified.

Safety instructions for usage

The only persons allowed to work on the electrical equipment are competent staff members who work in accordance with regulations and standards for high-voltage equipment.

No persons under the influence of drugs, alcohol or medication which affects their ability to react, are allowed to use, maintain, or repair the construction.

All stated actions and instructions relating to work protection and issues relating to general safety and protection of workers that should be carried out or studied prior to, during or following operation must be followed to the letter. Failure to do so may result in fatal accidents.

The equipment should be stopped or taken out of operation at the time of detection of faults relating to work protection and operational accessibility.

Safety equipment must not be deactivated, altered or used in a way that conflicts with applicable regulations.

Appropriate actions must be taken to ensure safe operation and functional conditions for the user.

The equipment should only be used when all protective and safety equipment, such as detachable guards and emergency stop devices, are in place and in working order.

Any type of modification and alteration of the equipment is prohibited. However, this does not apply to lesser changes that do not affect the strength, operational safety or work protection, or to actions which promote an increased level of safety.

The fundamental responsibility for these changes lies with the user. If in doubt, contact RonI for written approval of the actions prior to implementation.

The equipment should be stopped and locked immediately when functional faults occur. Faults should be corrected immediately!

Following an "emergency stop" the user has to wait for the cause of the disruption to be repaired and for an assurance that there is no further danger before he/she reconnects the equipment and resumes operation.

The equipment should be disconnected immediately in the following cases:

- when electrical equipment, cables and/or insulation material is damaged, or
- when work protection equipment is damaged.

Specific local circumstances or applications may lead to situations that were unknown at the time of writing this document. In such cases, the user must ensure safe operation and disconnect the equipment until measures to maintain safe operation have been carried out in conjunction with RonI or other authorised party.

Ensure that no one can become injured when they use the equipment prior to connecting/activating the equipment.

If the user notices the presence of persons who may become injured during operation, the operation should be discontinued immediately and must not be resumed until these persons have left the dangerous area.

The user must make sure that the equipment is in a perfect and operationally safe condition prior to all operations using the equipment.

The user should carry out all prescribed safety measures and make sure that automated procedures are completed when the equipment is disconnected (e.g. when there are deficiencies as regards operational and personal safety, an emergency situation exists, repair or maintenance is being carried out, damage is noticed or at the completion of work).

Work with the equipment is only allowed when the operator has been instructed to do so by his superior, and if the operator has knowledge of the equipment and its function.

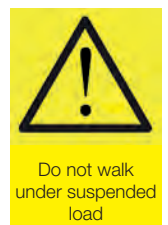

2. Technical data

Smooth and easily manoeuvred

Mechchain Pro II is an extremely easy-to-manoeuver lifting unit for professional lifting. Frequency control gives a stepless lifting speed controlled by a joystick. Mechchain Pro II combines high precision with an impressive lifting speed.

Low installation height

This lifting unit is suitable when a well-controlled and precise movement is required. Integrated in its travelling carriage, it has the lowest required ceiling height on the market, enabling installation also in cramped work spaces.

Encoder

Mechchain Pro II may optionally be equipped with an encoder that reads the axle in the spindle limit switch. This makes it possible to set a lower stop position, as well as a further two stop/start positions along the stroke. The positions are stored in a built-in memory in the frequency converter and are not erased in case of power cuts.

Integrated PLC & optional remote control

Mechchain Pro II has an integrated PLC which simplifies customized features. It is also possible to select remote control in cases where this facilitates handling.

Control units in aluminium

For high availability also in challenging environments, Mechchain Pro II has been equipped with control units in aluminium with quick connect to the control cable. There is also a selection of standard brackets as option, for easy mounting on gripper tools or vacuum yokes.

Suitable for many environments

Mechchain Pro II is available in weight classes: 63-80-125-225 kg.

Typical application areas are general lifting with slings or hooks, lifting within general industry, assembly work requiring high precision lifting, material handling with customized grippers, packing onto pallets and roller conveyors.

2.1 Properties and performance

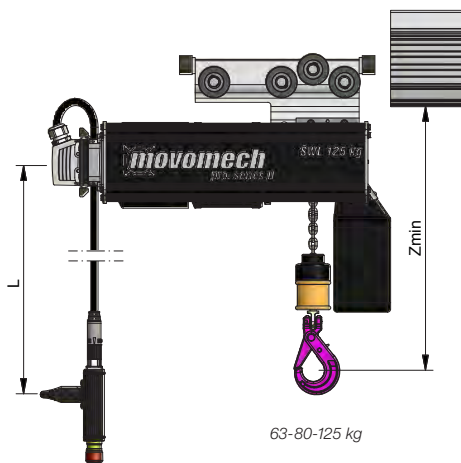

63-80-125 kg

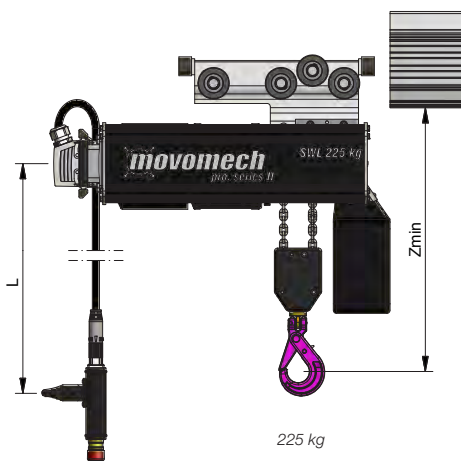

225 kg

Technical data		Mechchain Pro II
Max load	kg	63 / 80 / 125 / 225
Tare weight	kg	20
Stroke SL	mm	5000 / 3500 ¹
Lifting speed	m/min	- ²
Height Z _{min}	mm	420
Lifting chain	mm	Ø4x12
Cable length L	m	2,5 / 3 / 3,5 / 4 / 4,5

¹ 5000: 63-80-125 kg
3500: 225 kg

² Depends on configuration, see table.

Media & Environment		Mechchain Pro II
Motor output	kW	0,37
Voltage	V	1x230, N, PE (±15) 50/60 Hz
Fuse	AT	10
Enclosure class	IP	54
Mechanism group	-	3m / M6
Work temperature	°C	5-40 (indoor use)
Noise level	dB (A)	<70

2.2 Overview

Control cable

Integrated trolley or trolley adapter

Control unit with separate emergency stop

Remote control

STD: standard hook
SFY: safety hook

STD SFY

Base model	742954	742912	743020
For profile	-	LHB	PHB1 / AHB1.1-2

Configuration	743010	743009	743008	743007	743006	743005	743004	743003
Max. load kg	63	63	80	80	125	125	225	225
Stroke SL mm	5000	5000	5000	5000	5000	5000	3500	3500
Lifting speed m/min	0-16	0-16	0-15	0-15	0-12	0-12	0-7	0-7
Hook	-	STD	SFY	STD	SFY	STD	SFY	STD

Control unit with integrated emergency stop

3. Sub-assemblies

3.1 Base models

742954		Mechchain Pro II LHB		
#	Article nr.	Designation	Quantity	
1	731016	Trolley Mechchain LHB		1
2	742909	Worm gear motor 0.37 kW	R	1
3	742921	Electrical cabinet		1
4	730306	Screw MC6S M5x10		2
5	730266	Screw MC6S M6x16		4
6	731019	Chain sprocket	R	1
7	731020	Distance ring		1
8	731022	Engine bracket		1
9	731023	Chain guide	R	1
10	731129	Flat key 6x6-70		1
11	731408	Screw MC6S M6x50		2
12	731411	Screw MC6S M4x20		2
13	731414	Washer 10,5x28x6		1
14	731415	Screw M6S M10x20, full thread		1
15	731421	Chain collector		1
16	731426	Shaft protection		1
17	731427	Distance shaft		4
18	731428	Guiding for chain sprocket	R	1
19	731429	Screw MSK6SS M6x12		1
20	730268	Washer BRB 6,4x12x1.5		3
21	742913	Distance sleeve		1
22	730280	Screw MC6S M6x20		1
23	742952	Connector 6 pol		1

- Fits rail profile LHB.
- For configurations: 63-80 kg.

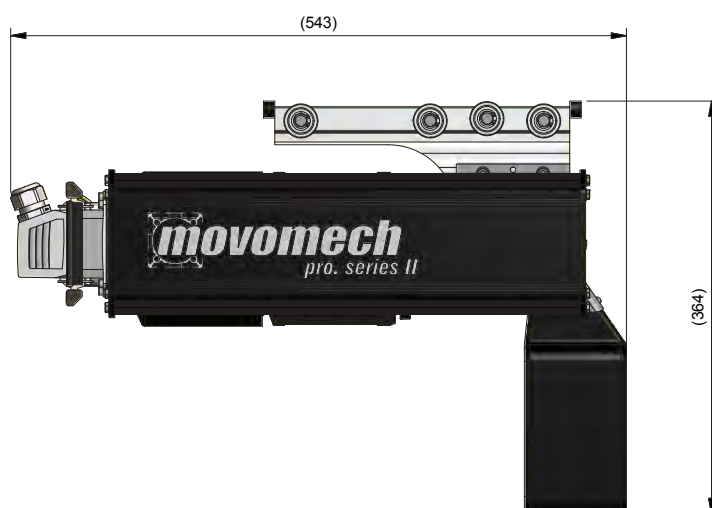

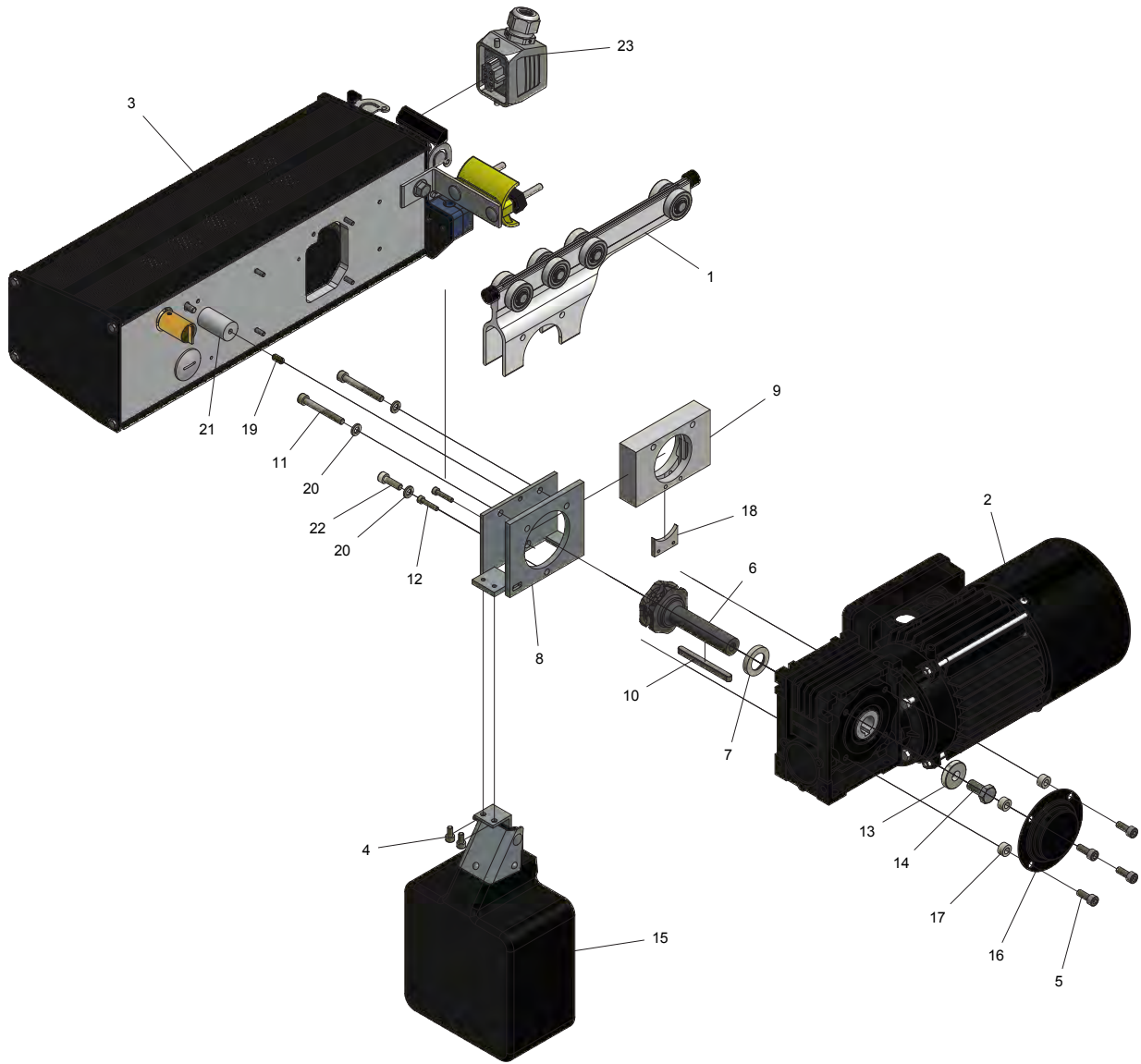

731016		Trolley Mechchain LHB	
#	Article nr.	Designation	Quantity
1	731017	Trolley body, Mechchain LHB	1
2	730206	Wheel LHB	R 8
3	730203	Wheel shaft LHB	4
4	730205	Retaining ring	8
5	730204	Shim ring 10x16x1	8
6	730207	Cylindrical damper	2

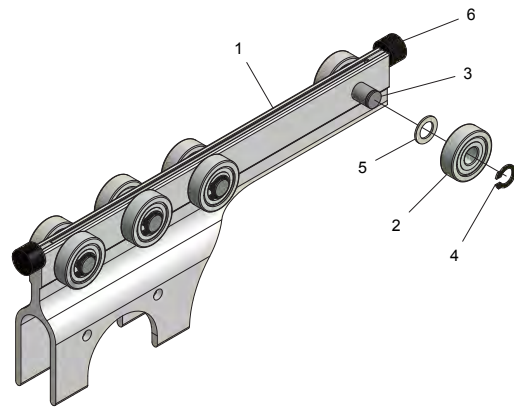

742912		Mechchain Pro II AHB	
#	Article nr.	Designation	Quantity
1	742911	Trolley Mechchain AHB	1
2	742909	Worm gear motor 0.37 kW	R 1
3	742921	Electrical cabinet	1
4	730306	Screw MC6S M5x10	2
5	731019	Chain sprocket	R 1
6	731020	Distance ring	1
7	731022	Engine bracket	1
8	731023	Chain guide	R 1
9	731129	Flat key 6x6-70	1
10	731408	Screw MC6S M6x50	2
11	731411	Screw MC6S M4x20	2
12	731414	Washer 10,5x28x6	1
13	731415	Screw M6S M10x20, full thread	1
14	731421	Chain collector	1
15	731426	Shaft protection	1
16	731427	Distance shaft	4
17	731428	Guiding for chain sprocket	R 1
18	731429	Screw MSK6SS M6x12	1
19	730266	Screw MC6S M6x16	4
20	730268	Washer BRB 6,4x12x1.5	3
21	742913	Distance sleeve	1
22	730280	Screw MC6S M6x20	1
23	742952	Connector 6 pol	1

- Fits rail profiles PHB1, AHB1.1 and AHB2.
- For configurations: 63-80-125-225 kg.

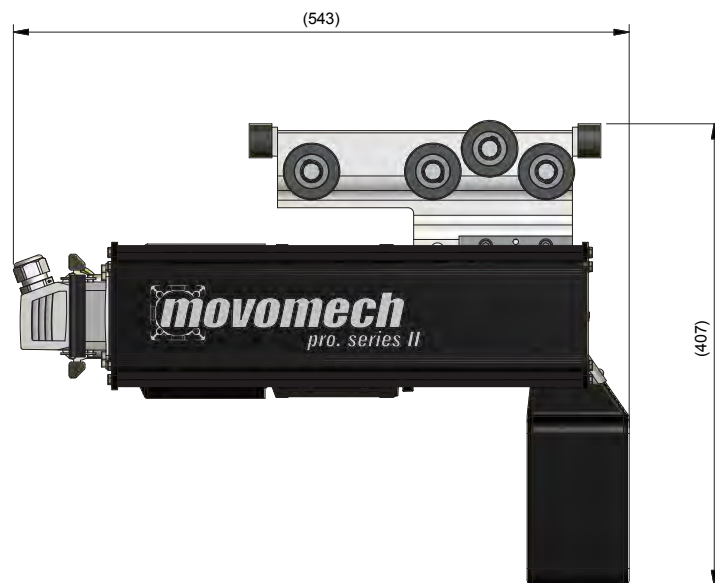

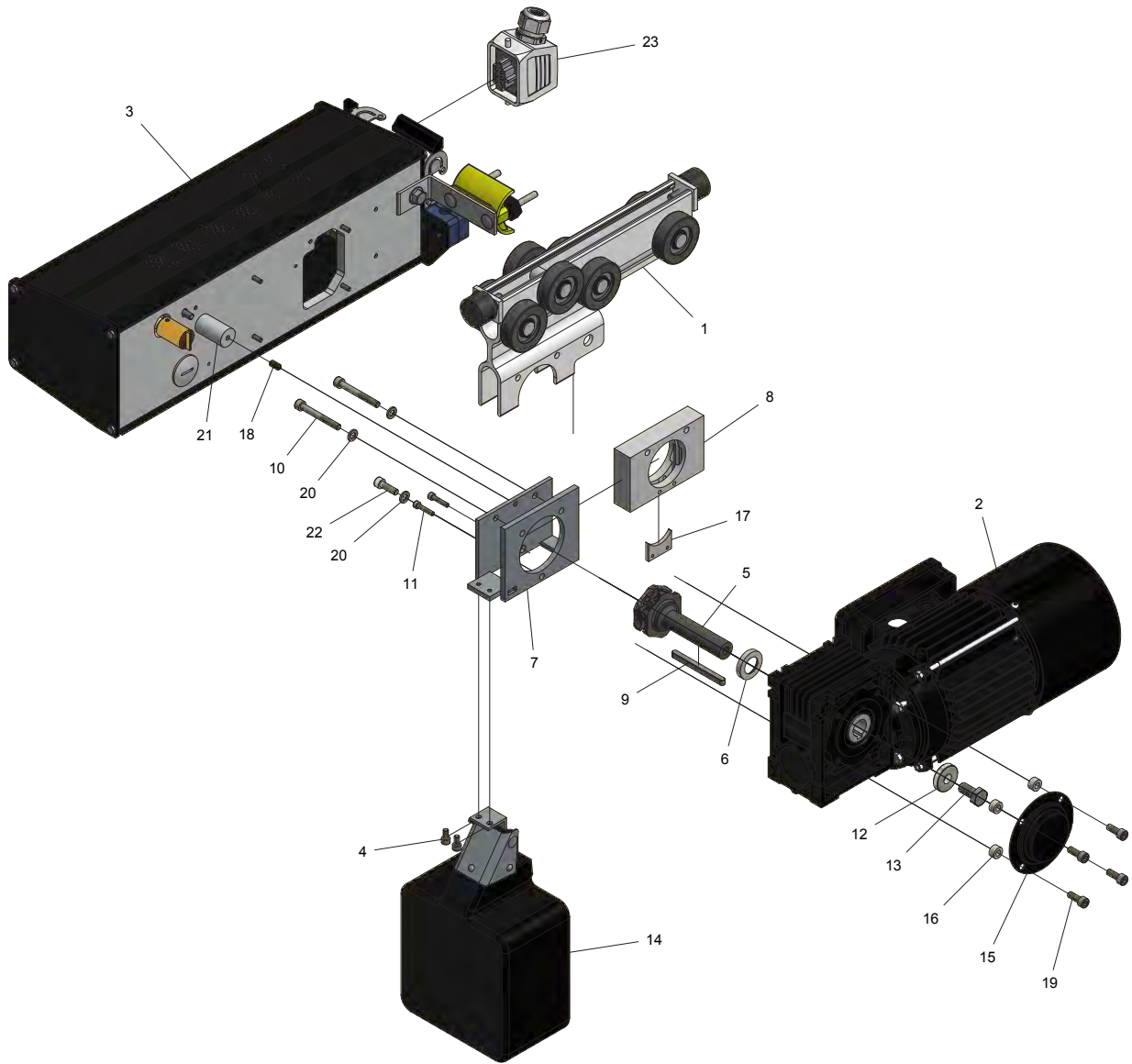

#	Article nr.	Designation	Quantity
742911 Trolley Mechchain AHB			
1	742910	Trolley body, Mechchain AHB	1
2	730327	Wheel shaft AHB1.1-2	4
3	730324	Wheel AHB1.1-2	R 8
4	730329	Retaining ring	8
5	730449	Rubber damper	2
6	730714	Damper plate	2
7	730820	Screw MF6S M5x12	4
8	730328	Washer 15x20x3,8	8

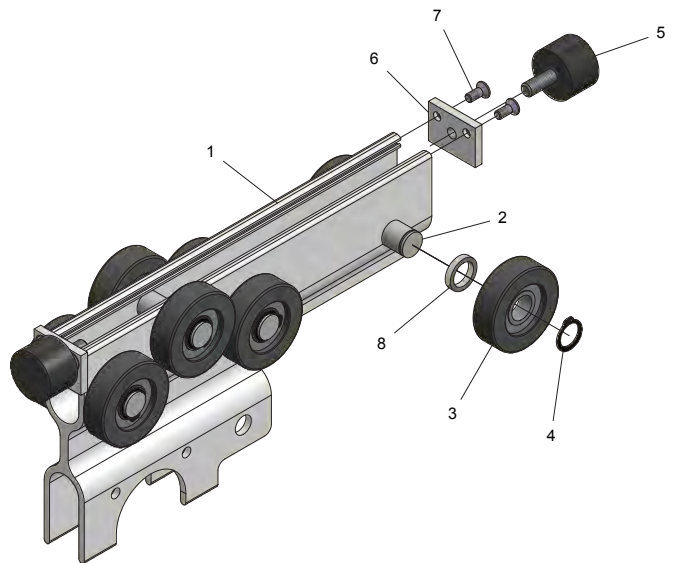

743020		Mechchain Pro II universal		
#	Article nr.	Designation	Quantity	
1	743017	Trolley adapter	1	
2	742909	Worm gear motor 0.37 kW	R	1
3	742921	Electrical cabinet	1	
4	730306	Screw MC6S M5x10	2	
5	731019	Chain sprocket	R	1
6	731020	Distance ring	1	
7	731022	Engine bracket	1	
8	731023	Chain guide	R	1
9	731129	Flat key 6x6-70	1	
10	731408	Screw MC6S M6x50	2	
11	731411	Screw MC6S M4x20	2	
12	731414	Washer 10,5x28x6	1	
13	731415	Screw M6S M10x20, full thread	1	
14	731421	Chain collector	1	
15	731426	Shaft protection	1	
16	731427	Distance shaft	4	
17	731428	Guiding for chain sprocket	R	1
18	731429	Screw MSK6SS M6x12	1	
19	730266	Screw MC6S M6x16	4	
20	730268	Washer BRB 6,4x12x1.5	3	
21	742913	Distance sleeve	1	
22	730280	Screw MC6S M6x20	1	
23	742952	Connector 6 pol	1	

- With trolley adapter.
- For configurations: 63-80-125-225 kg

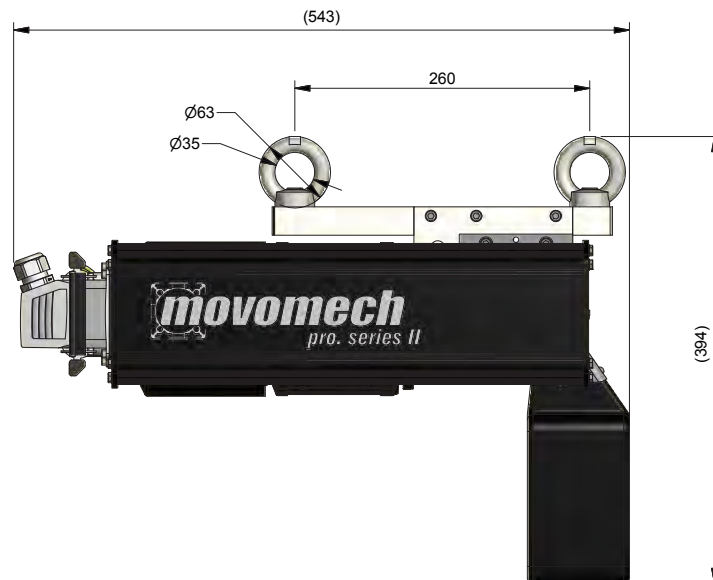

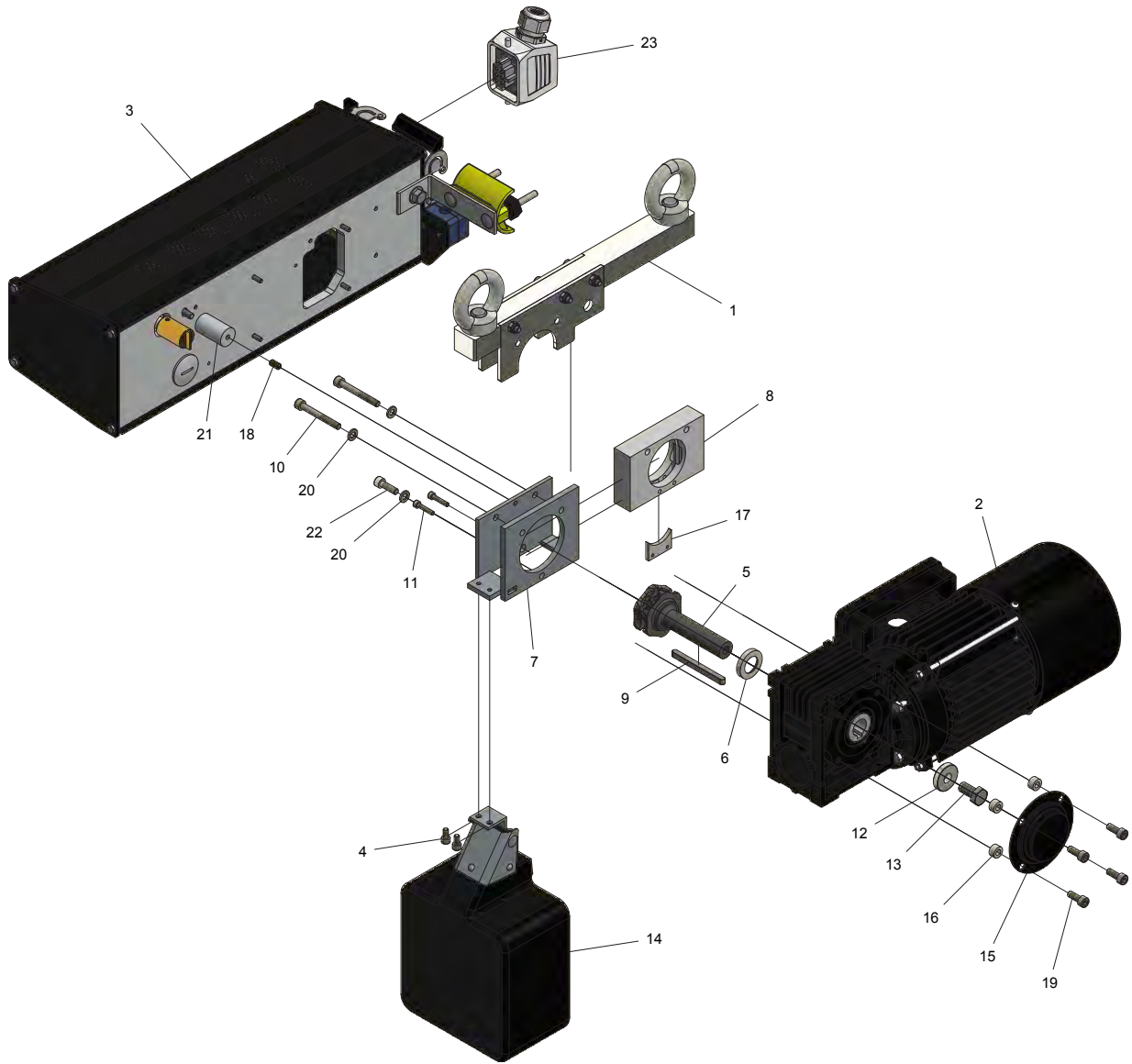

743017 Trolley adapter

#	Article nr.	Designation	Quantity
1	743019	Adapter body	1
2	743018	Side plate	2
3	730380	Lifting eye nut M16	2
4	730273	Locking nut M6	3
5	730759	Screw MC6S M6x40	3
6	737307	Screw MC6S M16x25	2

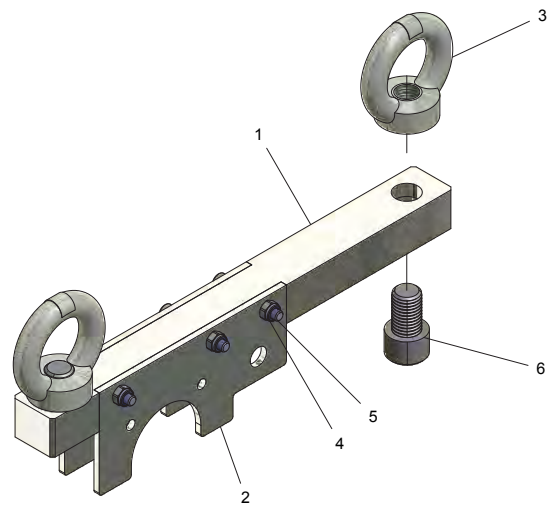

3.2 Configurations

7430xx		Standard hook 63-80-125 kg		
#	Article nr.	Designation	Quantity	
1	731419	Lifting chain Ø4x12	S	5,5
2	731418	Standard hook	R	1
3	731417	End stop with damper		1
(4)	*1	Decal (load) kg silver		1

Configuration		743010	743008	743006
Max load	kg	63	80	125
For base model	-	LHB/AHB	AHB	AHB
Article nr	*1	743014	743013	743012

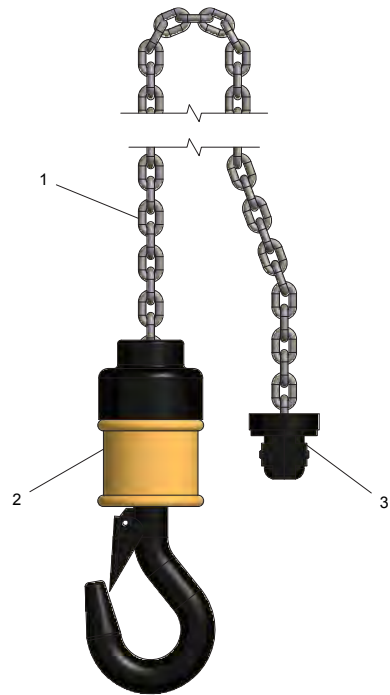

7430xx		Safety hook 63-80-125 kg		
#	Article nr.	Designation	Quantity	
1	731419	Lifting chain Ø4x12	S	5,5
2	731637	Safety hook	R	1
3	731417	End stop with damper		1
(4)	*1	Decal (load) kg silver		1

Configuration		743009	743007	743005
Max load	kg	63	80	125
For base model	-	LHB/AHB	AHB	AHB
Article nr	*1	743014	743013	743012

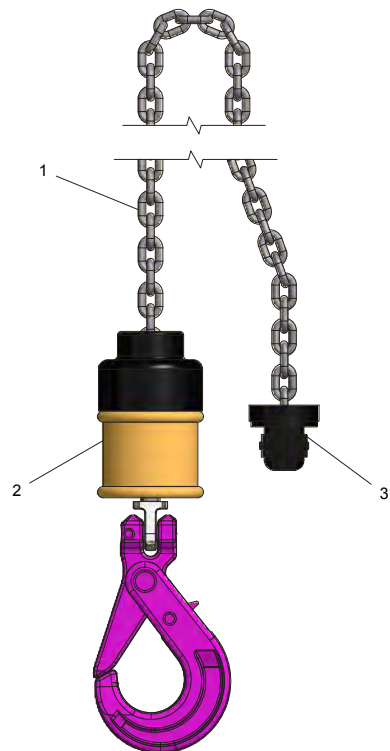

743004 Safety hook 225 kg

#	Article nr.	Designation	Quantity	
1	731419	Lifting chain Ø4x12	S	8
2	742934	Safety hook, 2 part	R	1
3	731417	End stop with damper		1
4	742940	Chain bracket		1
(5)	743011	Decal 225 kg silver		1

Configuration

743004

Max load	kg	225
For base model	-	AHB

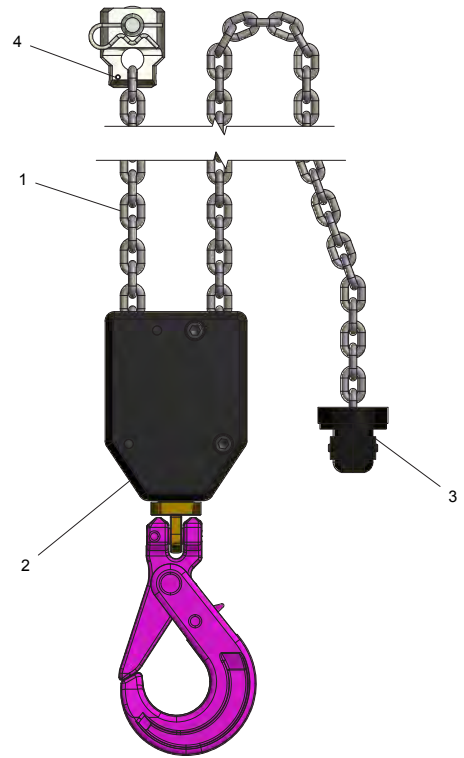

742934 Safety hook, 2 part

#	Article nr.	Designation	Quantity	
1	730587	Ball bearing	R	2
2	742938	Chain sprocket for bearing	R	1
3	742961	Safety hook		1
4	733691	Screw MC6S M6x30		4
5	742960	Swivel adapter		1
6	742936	Hook housing, half		2

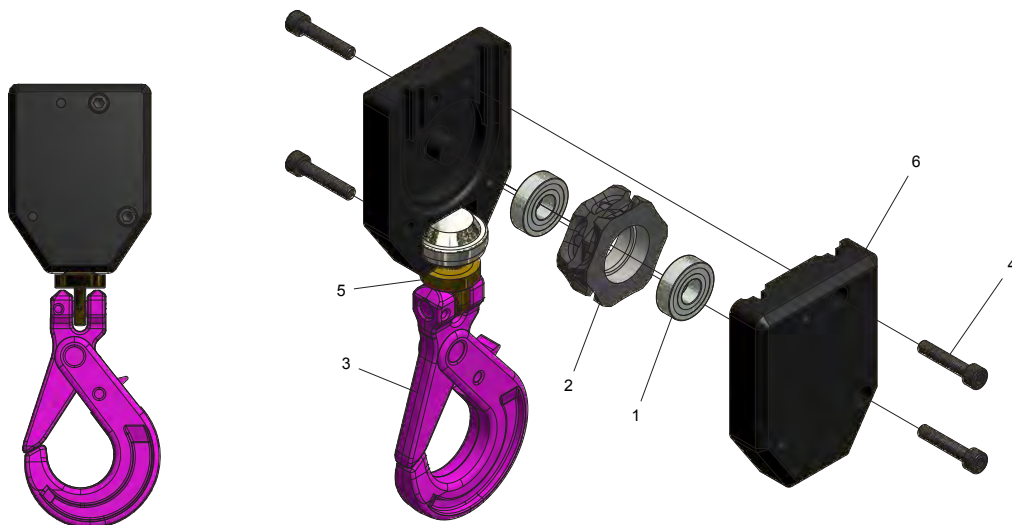

4. Control units

4.1 Combinations with standard cable



A	
74295x	1
742195	1

B	
74295x	1
742196	1

C	
74295x	1
742197	1



74295x	742955	742956	742957	742958	742959
Length L m	2,5	3,0	3,5	4,0	4,5

742195 Control unit with emergency stop

#	Article nr.	Designation	Quantity
1	732307	Joystick JC100	R 1
2	731740	Emergency stop assembly	R 1
3	731523	Locking nut M3	4
4	731522	Screw K6S M3x12 black	7
5	742184	Counterplate	1
6	742185	Joystick box	1
7	742187	Gable, emergency stop	1
8	742189	Gable, M17	1
9	742257	PCB	1
10	742265	Screw K6S M3x16 black	1
11	742945	Flange plug M17 8 pol male	1

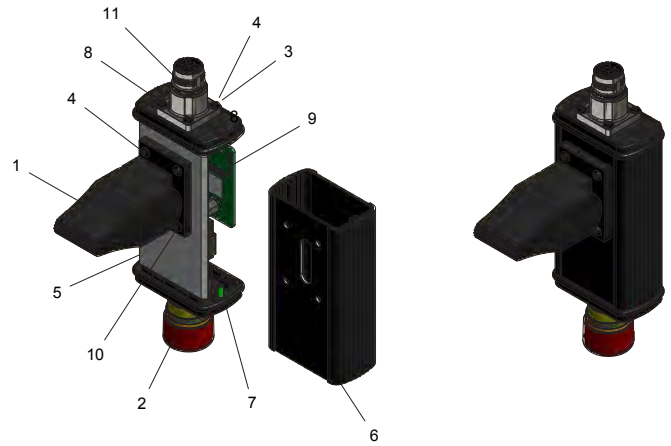

742196 Control unit with protection + emergency stop

#	Article nr.	Designation	Quantity
1	732307	Joystick JC100	R 1
2	731740	Emergency stop assembly	R 1
3	731523	Locking nut M3	4
4	731522	Screw K6S M3x12 black	7
5	742182	Protection plate	1
6	742184	Counterplate	1
7	742185	Joystick box	1
8	742187	Gable, emergency stop	1
9	742189	Gable, M17	1
10	742257	PCB	1
11	742265	Screw K6S M3x16 black	1
12	742945	Flange plug M17 8 pol male	1

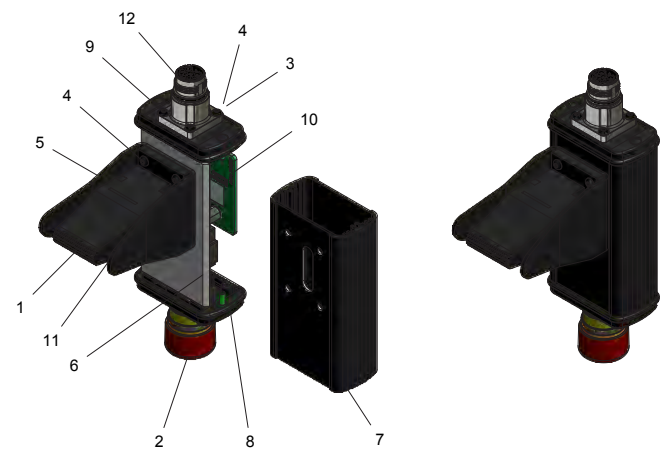

742197 Control unit with protection + em. stop + handle

#	Article nr.	Designation	Quantity
1	742946	Joystick JC100, worked	R 1
2	731740	Emergency stop assembly	R 1
3	731523	Locking nut M3	4
4	731522	Screw K6S M3x12 black	6
5	739357	Screw MF6S M3x12	1
6	742182	Protection plate	1
7	742184	Counterplate	1
8	742186	Joystick box	1
9	742187	Gable, emergency stop	1
10	742189	Gable, M17	1
11	742190	Handle	1
12	742257	PCB	1
13	742945	Flange plug M17 8 pol male	1
14	731861	Screw MC6S M8x12	1
15	742947	Screw MF6S M3x18	1

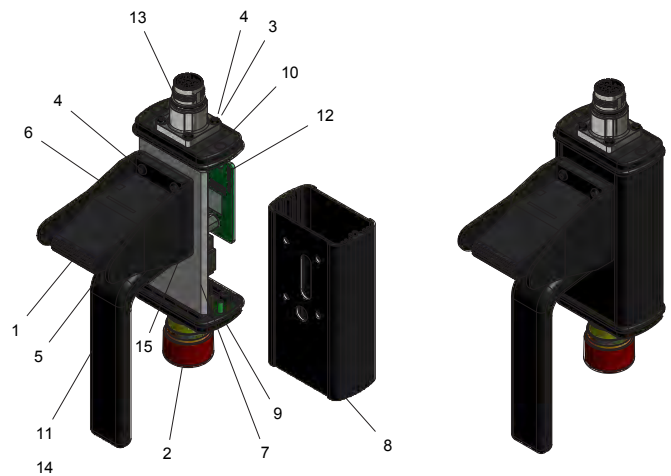

4.2 Combinations with spiral cable and integrated emergency stop

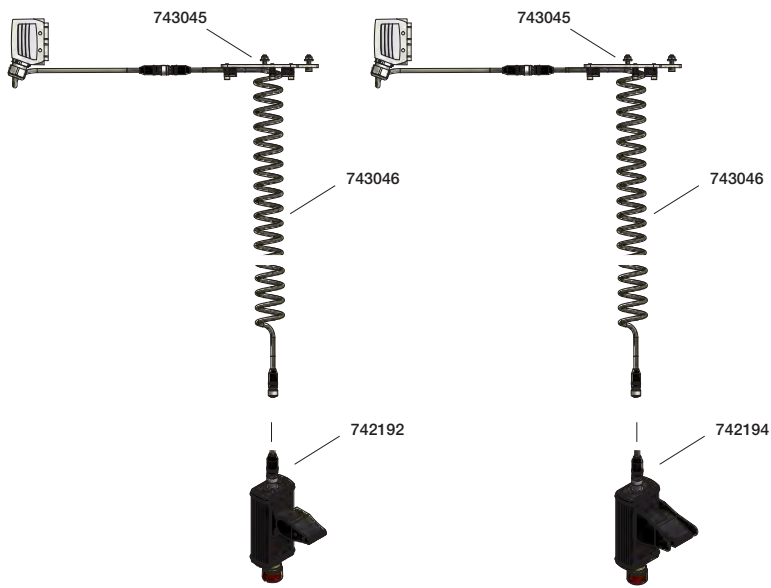

D	
746045	1
746046	1
742192	1

E	
743045	1
743046	1
742194	1

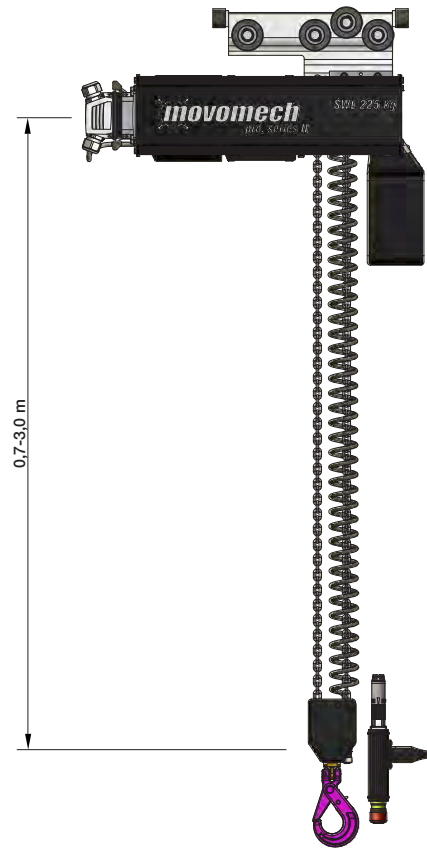

742192 Control unit with emergency stop

#	Article nr.	Designation	Quantity
1	742185	Joystick box	1
2	742184	Counterplate	1
3	742248	Gable M16x1.5	1
4	742188	Gable Ø16,2 mm	1
5	731740	Emergency stop assembly	R 1
6	732307	Joystick JC100	R 1
7	731522	Screw K6S M3x12 black	3
8	742265	Screw K6S M3x16 black	1
9	742257	PCB	1
10	740827	Flange plug M12 4 pol male	1

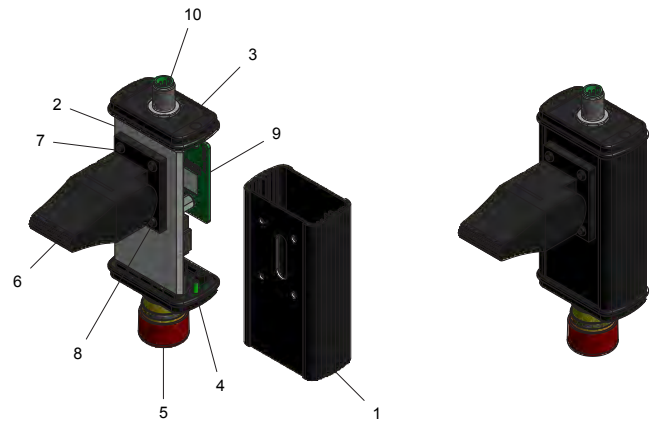

742194 Control unit with protection + emergency stop

#	Article nr.	Designation	Quantity
1	742185	Joystick box	1
2	742184	Counterplate	1
3	742248	Gable M16x1.5	1
4	742188	Gable Ø16,2 mm	1
5	731740	Emergency stop assembly	R 1
6	732307	Joystick JC100	R 1
7	731522	Screw K6S M3x12 black	3
8	742265	Screw K6S M3x16 black	1
9	742182	Protection plate	1
10	742257	PCB	1
11	740827	Flange plug M12 4 pol male	1

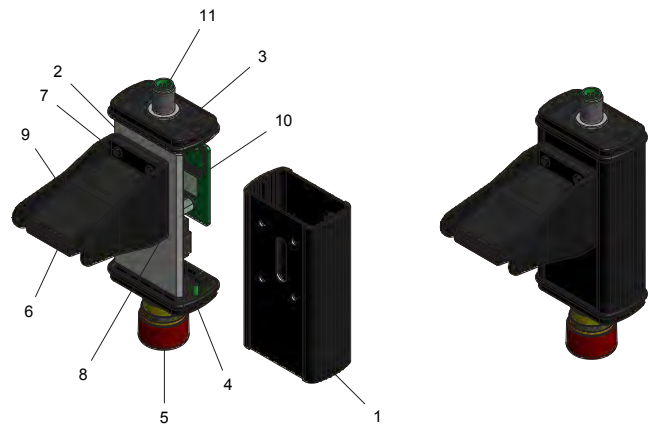

4.3 Combinations with spiral cable and separate emergency stop

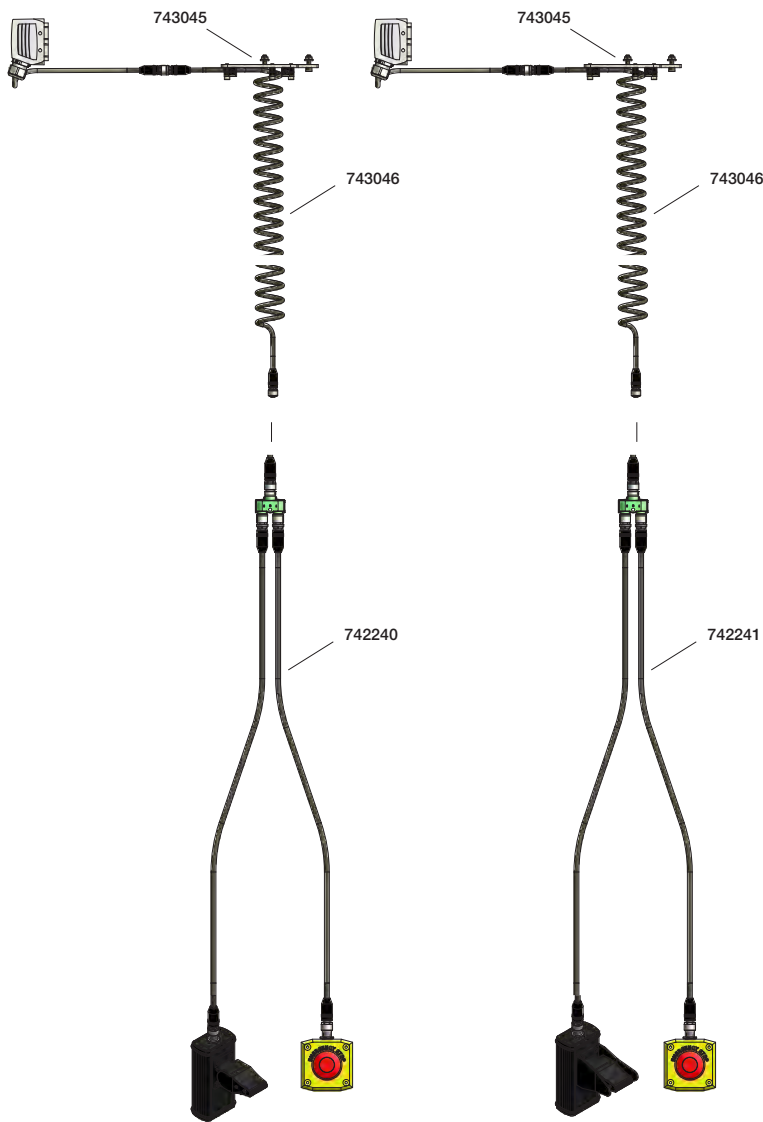

F	
743045	1
743046	1
742240	1

G	
743045	1
743046	1
742241	1

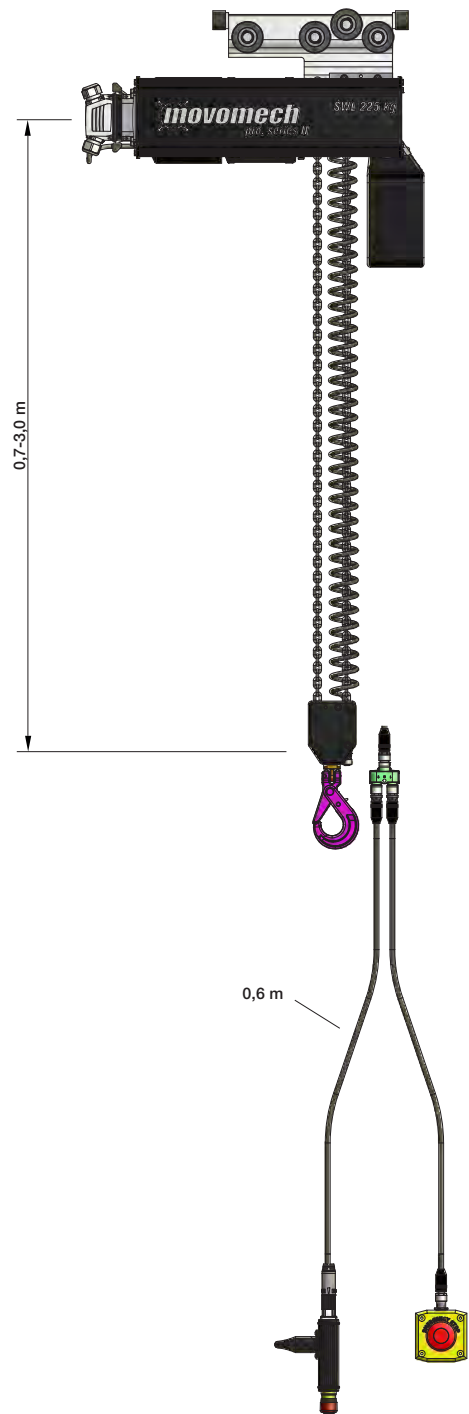

742240 Control unit external emergency stop			
#	Article nr.	Designation	Quantity
1	742191	Control unit	1
2	740457	Emergency stop, complete	R 1
3	740509	Y split 8 pol	1
4	740937	Cable, M12, 8 conductors, 0,6 m	2

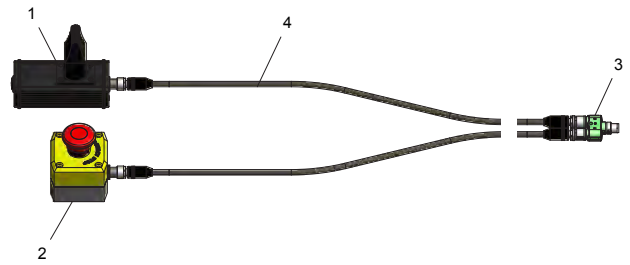

742241 Control unit with protection + ext. emergency stop			
#	Article nr.	Designation	Quantity
1	742193	Control unit with protection	1
2	740457	Emergency stop, complete	R 1
3	740509	Y split 8 pol	1
4	740937	Cable, M12, 8 conductors, 0,6 m	2

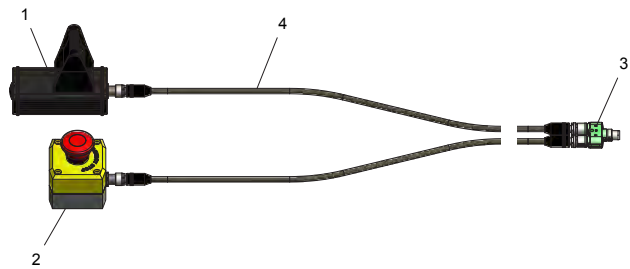

740457 Emergency stop, complete

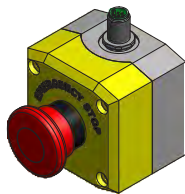

740509 Y split 8 pol



742191 Control unit			
#	Article nr.	Designation	Quantity
1	742185	Joystick box	1
2	742184	Counterplate	1
3	742248	Gable M16x1.5	2
4	732307	Joystick JC100	R 1
5	742238	Blind plug M16	1
6	731522	Screw K6S M3x12 black	3
7	742265	Screw K6S M3x16 black	1
8	742257	PCB	1
9	740827	Flange plug M12 4 pol male	1

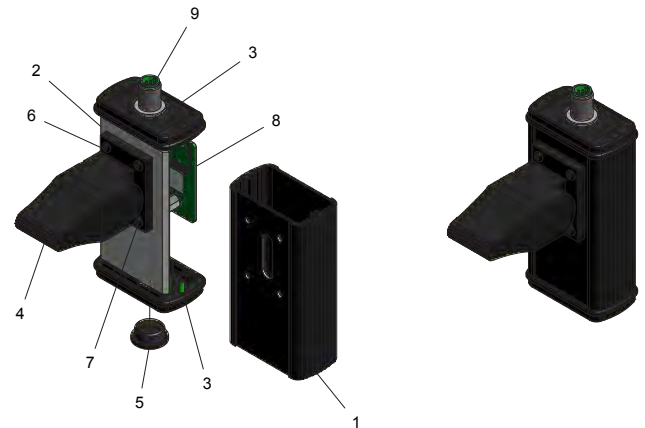

742193 Control unit with protection			
#	Article nr.	Designation	Quantity
1	742185	Joystick box	1
2	742184	Counterplate	1
3	742248	Gable M16x1.5	2
4	732307	Joystick JC100	R 1
5	742238	Blind plug M16	1
6	731522	Screw K6S M3x12 black	3
7	742265	Screw K6S M3x16 black	1
8	742182	Protection plate	1
9	742257	PCB	1
10	740827	Flange plug M12 4 pol male	1

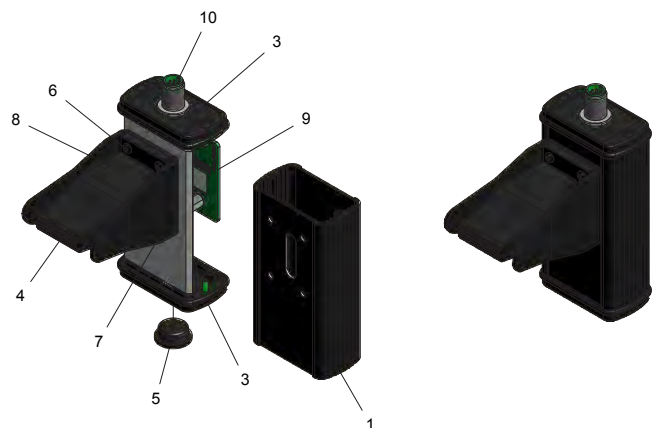

4.4 Remote control

743024 Radio control Mechchain Pro II			
#	Article nr.	Designation	Quantity
1	742225	Power supply 24 VDC	1
2	743023	Receiver, radio control	1
3	743026	Transmitter unit	1

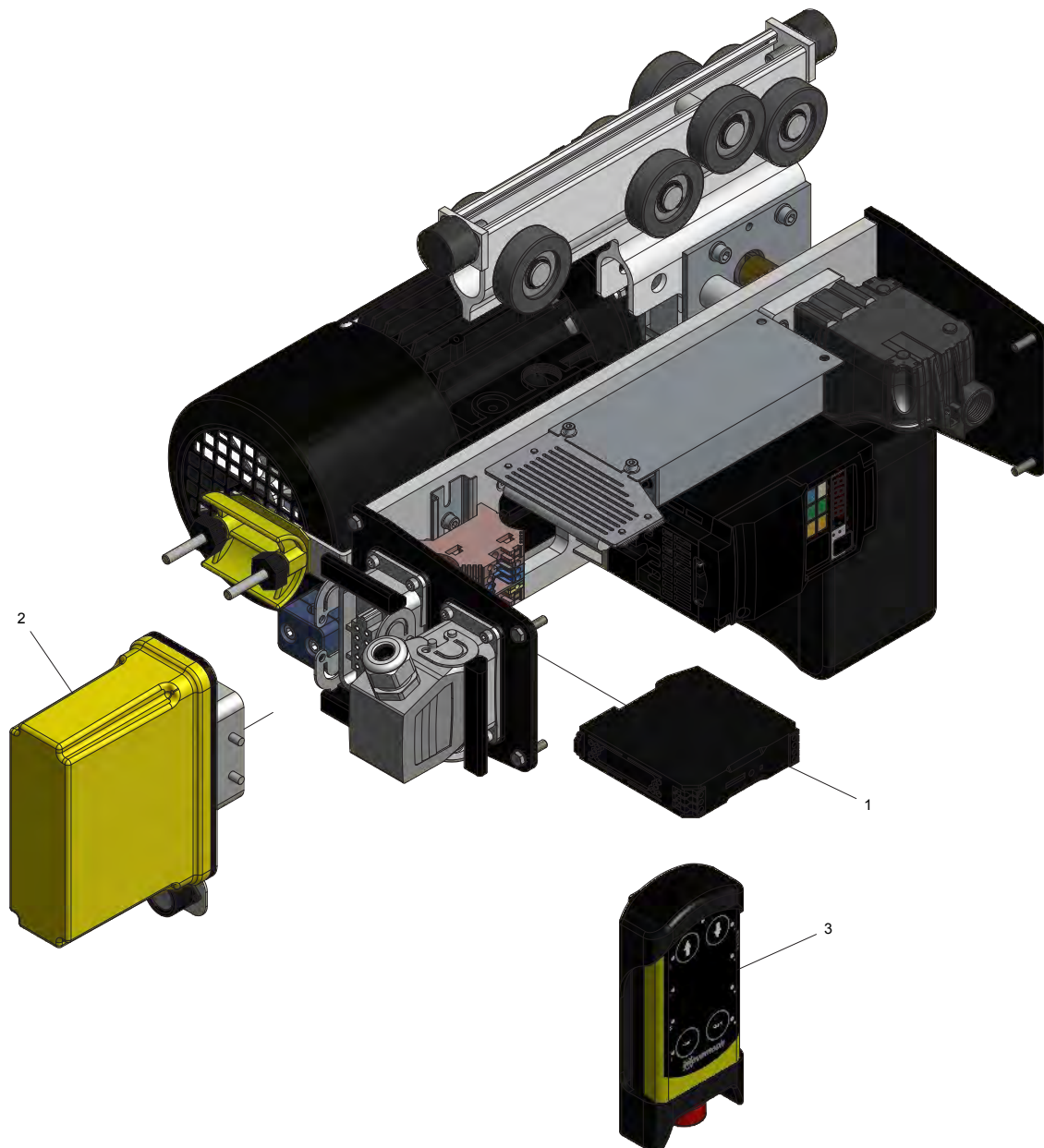

- Rechargeable transmitter
- Operating time 30 hours
- Protection class IP66

5. Accessories

5.1 Encoder

742953 Encoder kit for positioning			
#	Article nr.	Designation	Quantity
1	742225	Power supply 24 VDC	1
2	742228	Terminal, blue	1
3	742229	Terminal, grey	1
4	742230	End plate	1
5	742292	Terminal relay 24 VDC	1
6	742291	Encoder	1

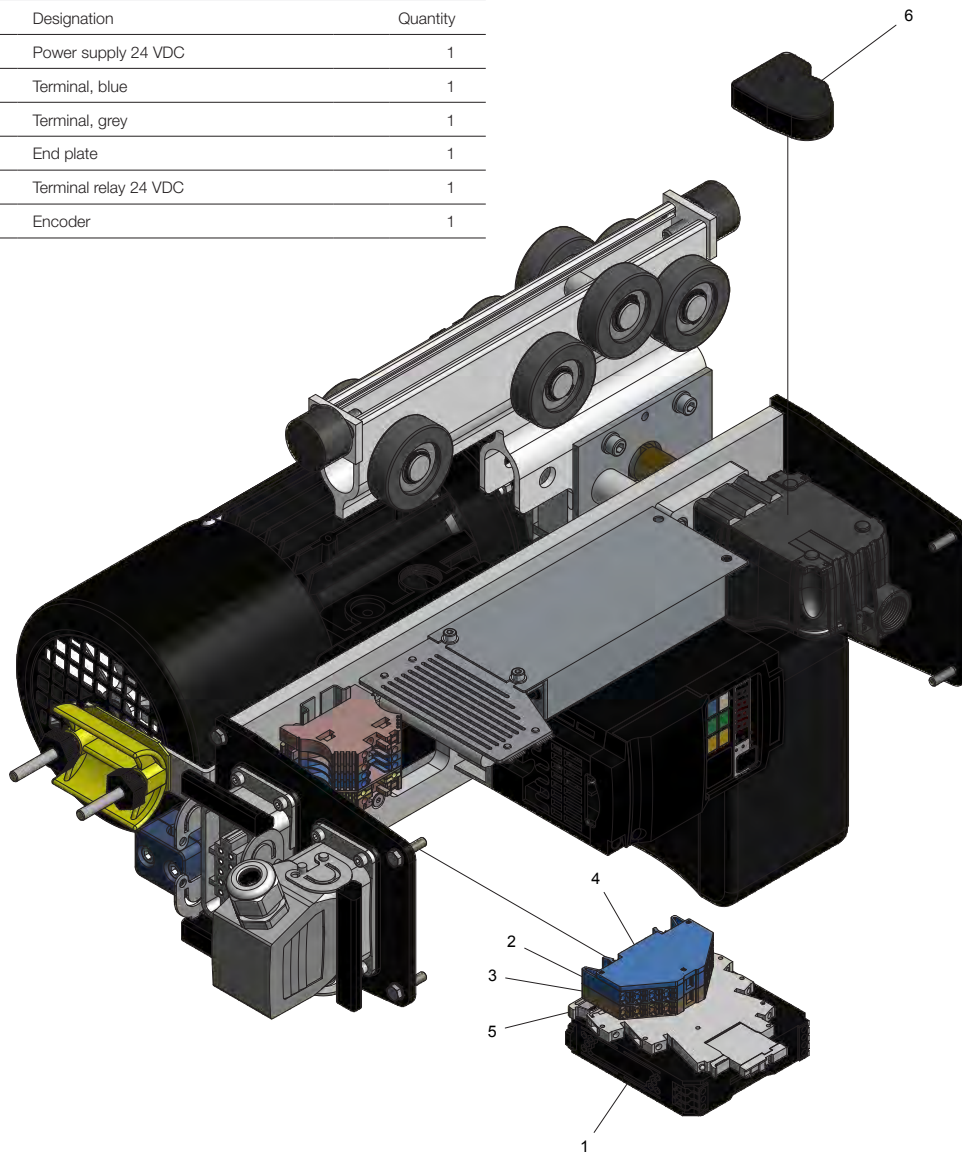

- The encoder simplifies positioning in the Z direction
- Mounted in the rotary limit switch.
- Teach-in function.
- Connected directly to Mechchain Pro II (no external PLC required).

5.2 Brackets for control units

742242 Mounting clip

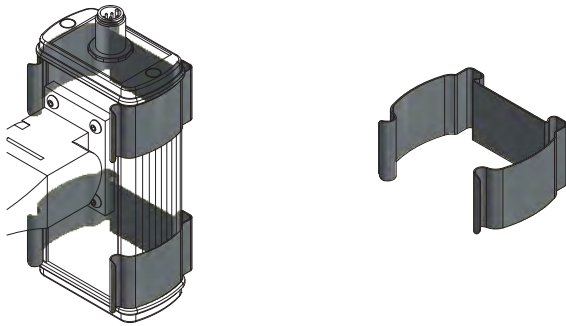

- Supplied individually.

742243 Wall bracket

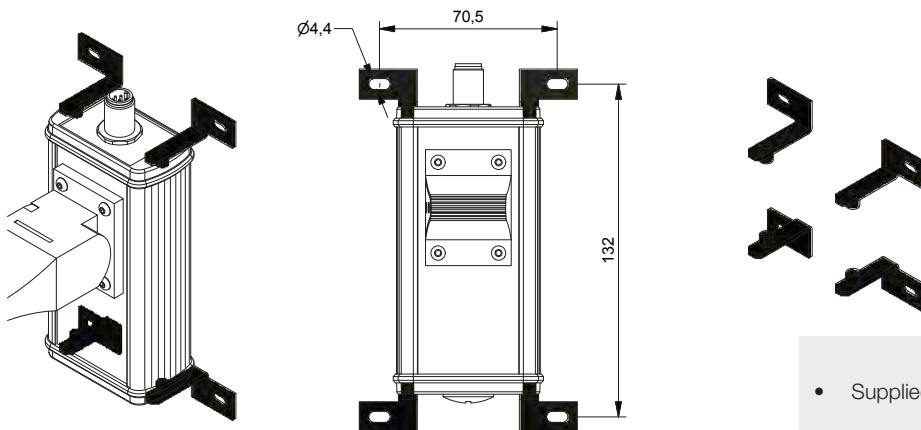

- Supplied in set (2x up + 2x down).

742244 Adjustable wall bracket

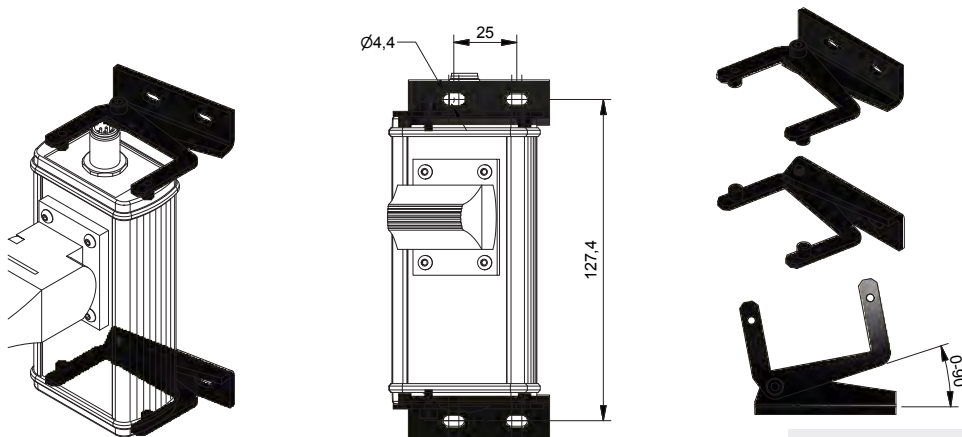

- Supplied in set (1x up + 1x down).

5.3 Balancer for cable

733243 Balancer for cable

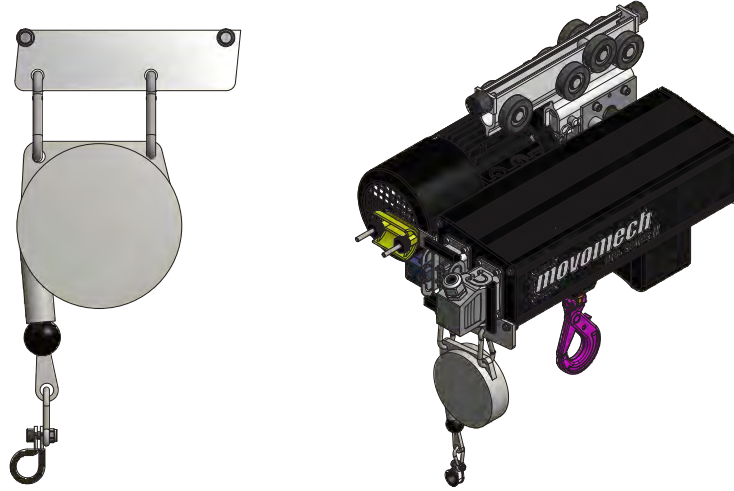

5.4 Spiral hose with bracket

743045 Bracket

736349 Spiral hose Ø8 L = max 6 m

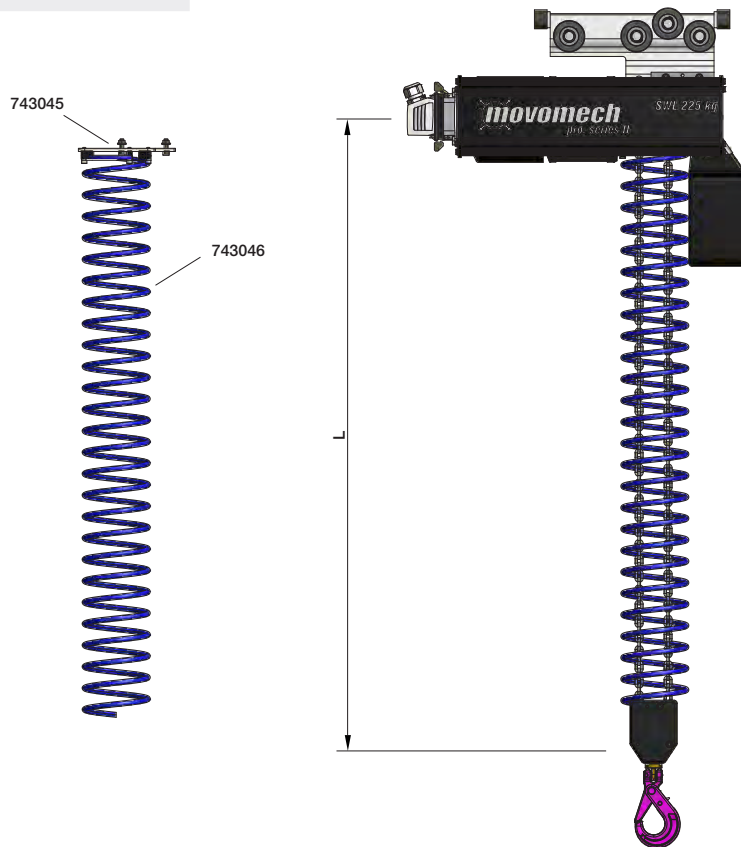

6. Circuit diagram and parameter settings

6.1 Circuit diagram Mechchain Pro II

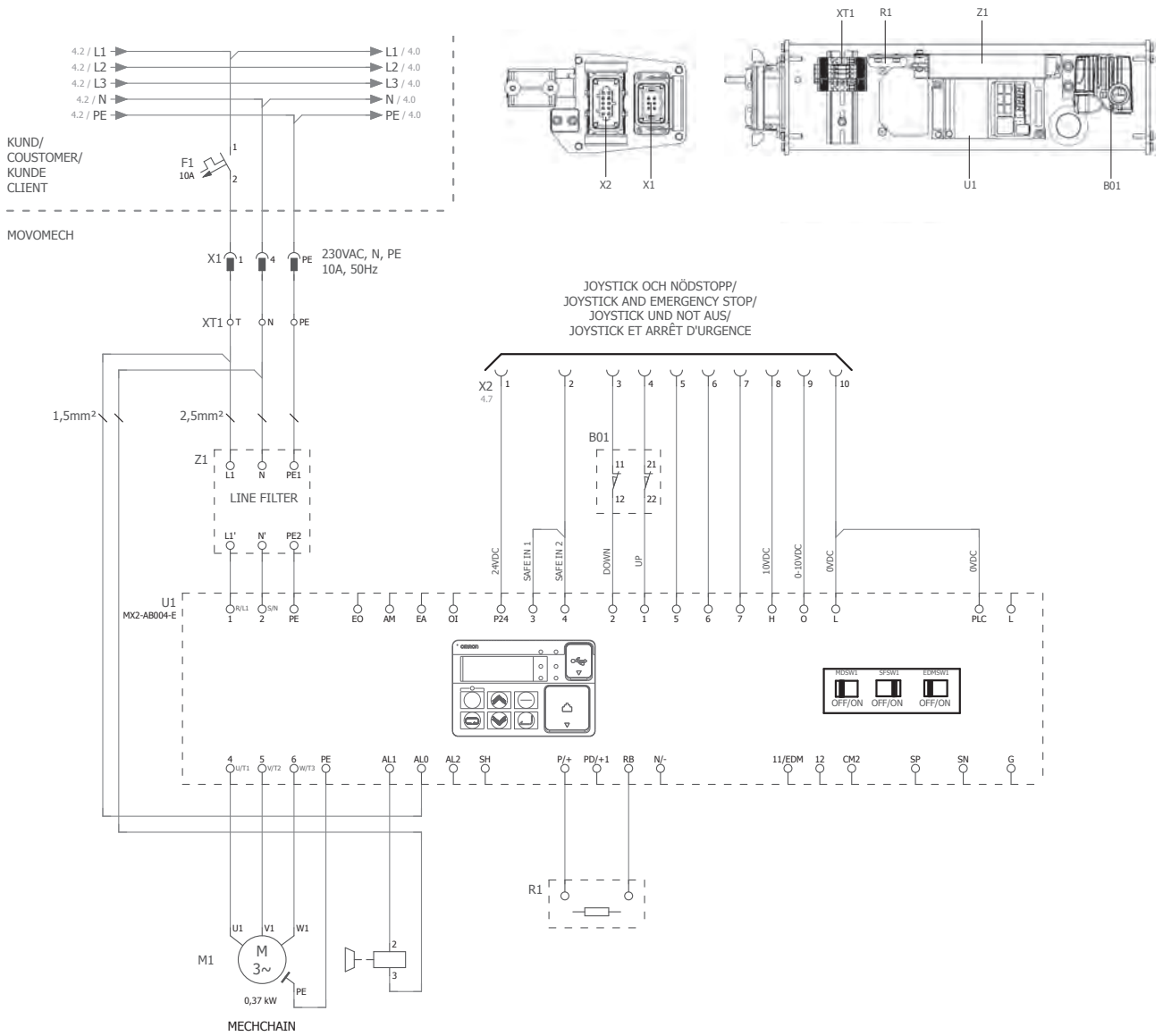

6.2 Electrical cabinet

742921		Electrical cabinet		
#	Article nr.	Designation	Quantity	
1	742922	Frequency inverter 0,4 kW	R*	1
2	742917	Rotary limit switch	R	1
3	742923	EMC filter	R	1
4	742926	Brake resistor	R	1
5	742914	Base plate		1
6	742933	Cover		1
7	731028	End plate		1
8	731409	Screw MC6S M6x25		2
9	732343	Bracket		1
10	732469	Terminal, blue		2
11	733265	End support		2
12	733270	End plate		1
13	734111	Blind plug PG21		1
14	734926	Insert part male 6 POL + PE		1
15	735332	Terminal, grey		1
16	736022	Terminal, PE		1
17	742942	Hose clamp Ø10, two-part		1
18	742924	DIN rail, L=105		1
19	742925	Bracket		1
20	742927	End plate 10 POL + 6 POL		1
21	742930	Mount 6 POL + PE		1
22	742931	Mount 10 POL + PE		1
23	742932	Insert female 10 POL + PE		1
24	730476	Sadle c/c 50, complete		1

* When ordering as spare part, specify the lifter's serial number for the loading of correct parameters and program.

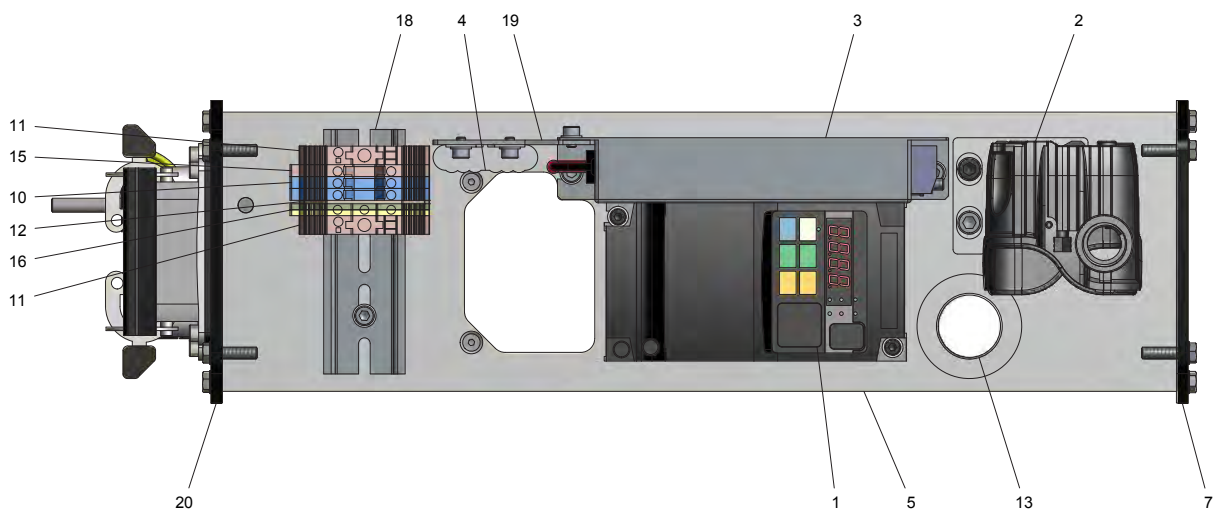
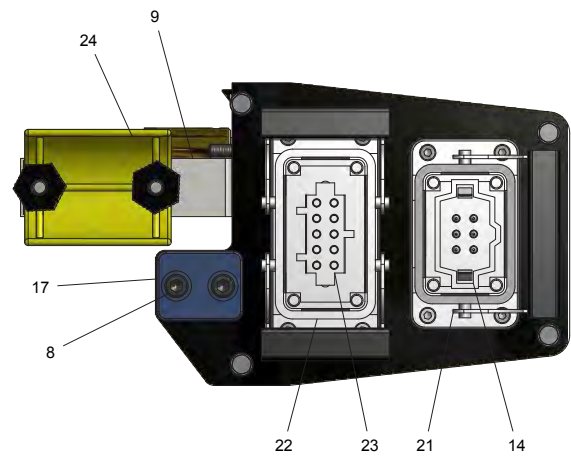
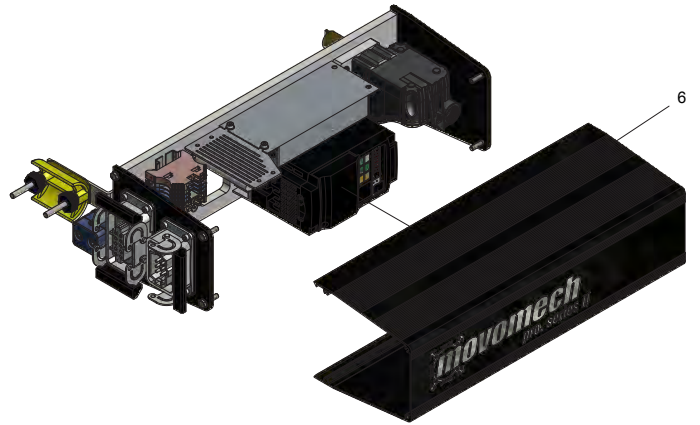

6.3 Circuit diagram Mechchain Pro II with encoder

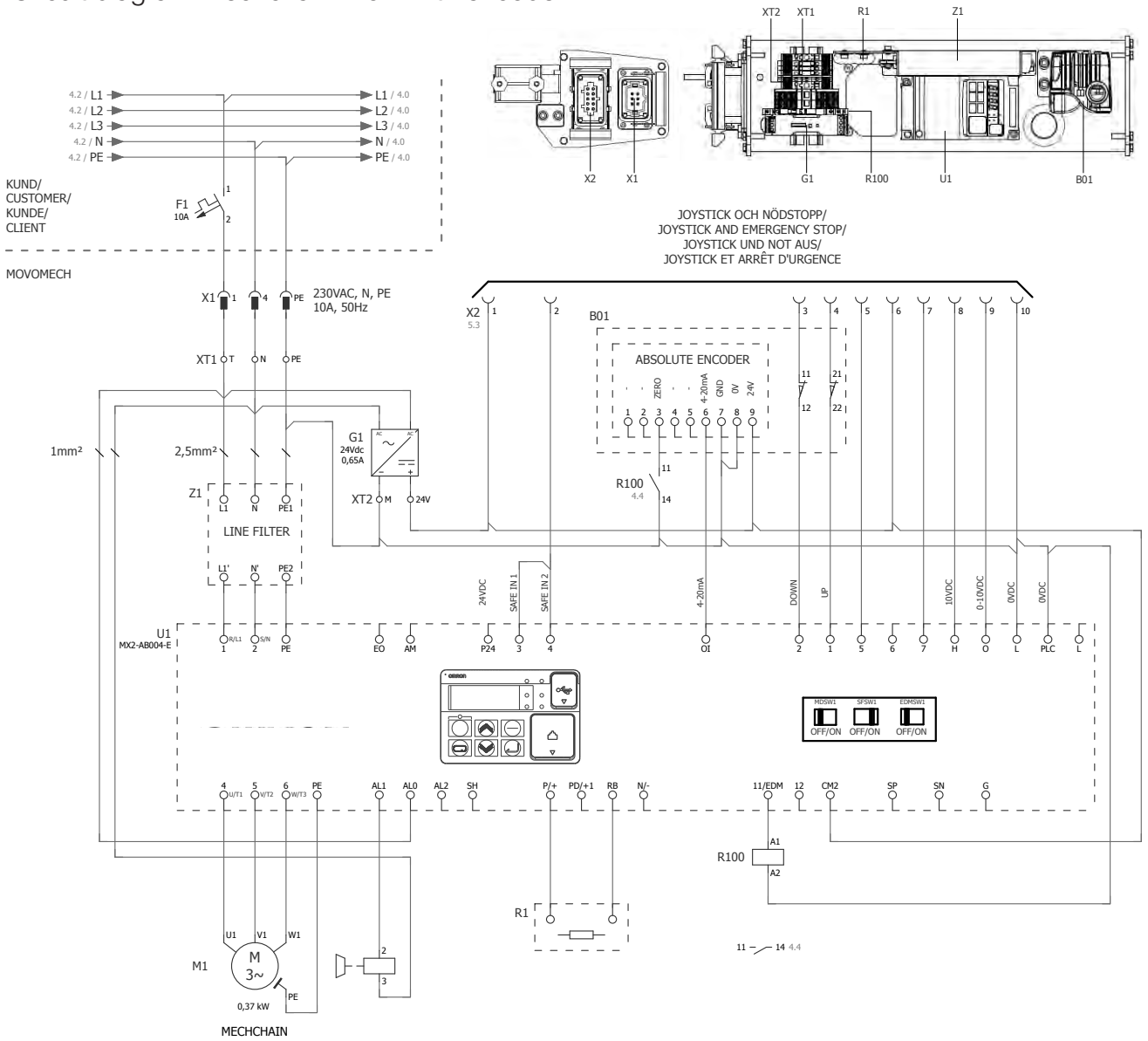

6.4 Circuit diagram Mechchain Pro II with remote control

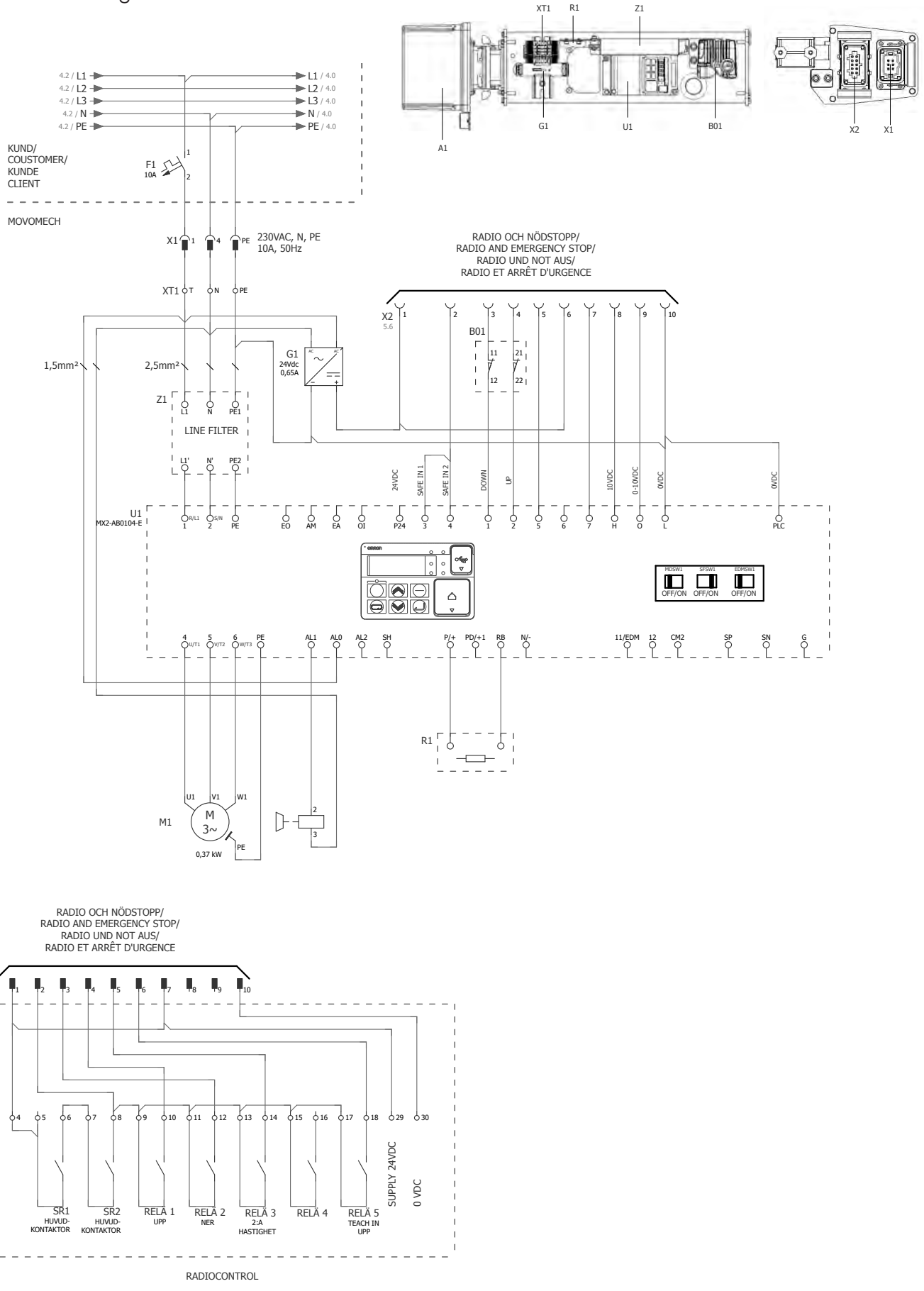

6.5 Circuit diagram control units

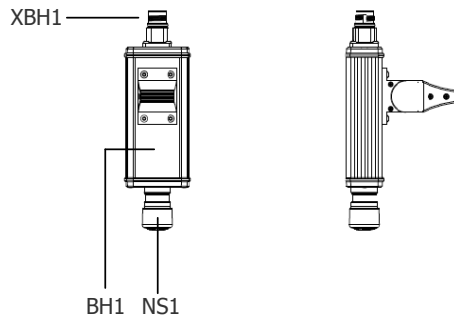
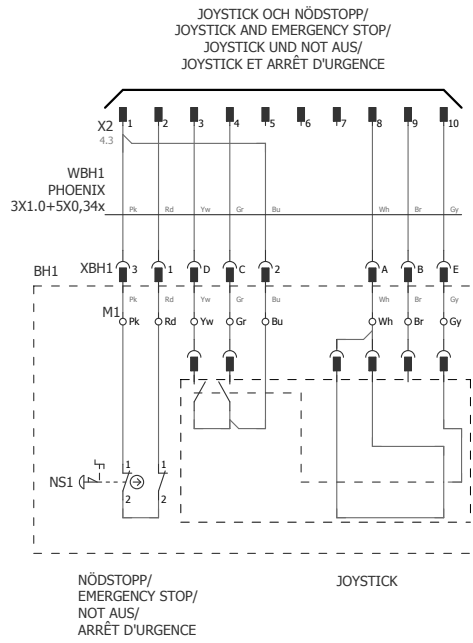

6.6 Parameter settings 63 - 80 - 125 - 225 kg

Index	Description	Value	Default	Range	Units
A001	Frequency Reference Selection 1	7: Drive Programming	1	0 to 10	
A003	Base Frequency 1	50	120	30,0 to 100,0	Hz
A004	Maximum Frequency 1	100	120	50,0 to 400,0	Hz
A012	O End Frequency	95	0	0,00 to 400,00	Hz
A013	O Start Ratio	6	0	0 to 94	%
A014	O End Ratio	94	100	6 to 100	%
A017	Drive Programming Selection	2: Always	0	0 to 2	
A044	Control Method 1	3: SLV (sensorless vector control)	0	0 to 3	
B012	Electronic Thermal Level 1	1,9	5	1,00 to 5,00	A
B038	Initial Screen Selection	2: d002 - Output current monitor	1	0 to 202	
B041	Torque Limit 1 (Four-quadrant Mode Forward Power Running)	30 (63 kg), 45 (80 kg), 65 (125 kg), 75 (225 kg)	200	0 to 255	%
B083	Carrier Frequency	15	10	2,0 to 15,0	kHz
B090	Usage Rate of Regenerative Braking	25	0	0,0 to 19,6	%
B095	Regenerative Braking Selection	1: Enabling [disabling while the motor is stopped]	0	0 to 2	
B097	BRD Resistor Value	200	50	50,0 to 600,0	Ohm
B164	Initial Screen Automatic Switching Function	1: Enabled	0	0 to 1	
C001	Multi-function Input [1] Selection	56: X(00) Drive Programming (MI1)	0	0 to 255	
C002	Multi-function Input [2] Selection	57: X(01) Drive Programming (MI2)	1	0 to 255	
C003	Multi-function Input [3] Selection	77: GS1 (GS1 input)	12	0 to 255	
C004	Multi-function Input [4] Selection	78: GS2 (GS2 input)	18	0 to 255	
C005	Multi-function Input [5] Selection	255: no (not used)	2	0 to 255	
C006	Multi-function Input [6] Selection	255: no (not used)	3	0 to 255	
C007	Multi-function Input [7] Selection	255: no (not used)	6	0 to 255	
C013	Multi-function Input Terminal [3] Operation Selection	1: NC	0	0 to 1	
C014	Multi-function Input Terminal [4] Operation Selection	1: NC	0	0 to 1	
C021	Multi-function Output Terminal [11]/EDM-Selection	44: Y(00) Programmation pilote (MO1)	0	0 to 255	
C022	Selection of multi-function Output Terminal [12]	45: Y(01) Programmation pilote (MO2)	1	0 to 255	
C026	Multi-function Relay Output (AL2, AL1) Function Selection	2: FA2 (Frequency Arrival Type 2 - surfréquence)	5	0 to 255	
C036	Multi-function Relay Output (AL2, AL1) Contact Selection	0: NO	1	0 to 1	
C042	Arrival Frequency During Acceleration	1	0	0,00 to 400,00	Hz
C043	Arrival Frequency During Deceleration	1	0	0,00 to 400,00	Hz
C081	O Adjustment	125	100	0,0 to 200,0	
C091	Debug Mode Selection	1: Enabled	0	0 to 1	
F002	Acceleration Time Setting 1	1	10	0,00 to 3600,00	sec
F003	Deceleration Time Setting 1	0,3	10	0,00 to 3600,00	sec
F202	Acceleration Time Setting 2	2	10	0,00 to 3600,00	sec
F203	Deceleration Time Setting 2	0,5	10	0,00 to 3600,00	sec
H002	Motor Parameter 1	2: Auto-tuned data	0	0 to 2	
H030	Motor 1 Parameter R1 (Auto-tuning Data)	8,034	2,984	0,001 to 65,535	Ohm
H031	Motor 1 Parameter R2 (Auto-tuning Data)	3,983	1,448	0,001 to 65,535	Ohm
H032	Motor 1 Parameter L (Auto-tuning Data)	58,07	12,97	0,01 to 655,35	mH
H033	Motor 1 Parameter I _o (Auto-tuning Data)	1	1,96	0,01 to 655,35	A
H034	Motor 1 Parameter J (Auto-tuning Data)	0,01	0,009	0,001 to 9999,000	kgm ²
P031	Acceleration/Deceleration Time Input Type	3: Drive Programming	0	0 to 3	

7. Installation and commissioning

7.1 Mechanical installation

Mechchain Pro II is advantageously installed in RonI aluminium rail system Mechrail.

1. Verify that the rail system is dimensioned for the total load including dynamic effects.
2. Check that end stops are mounted in all end points on the track and crane.
3. Dismount the affected end stop and install Mechchain Pro II in the rail system.
4. Remount the final end stop.



- **Note! The chain must be lubricated with the enclosed grease (tube).**

7.2 Electrical installation

Mechchain Pro II must be connected only to 1x230V, N, PE (± 15) 50/60 Hz.

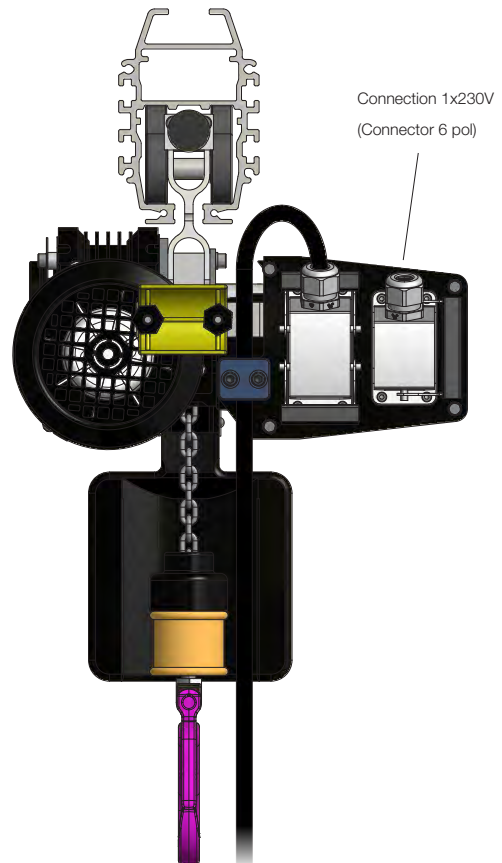
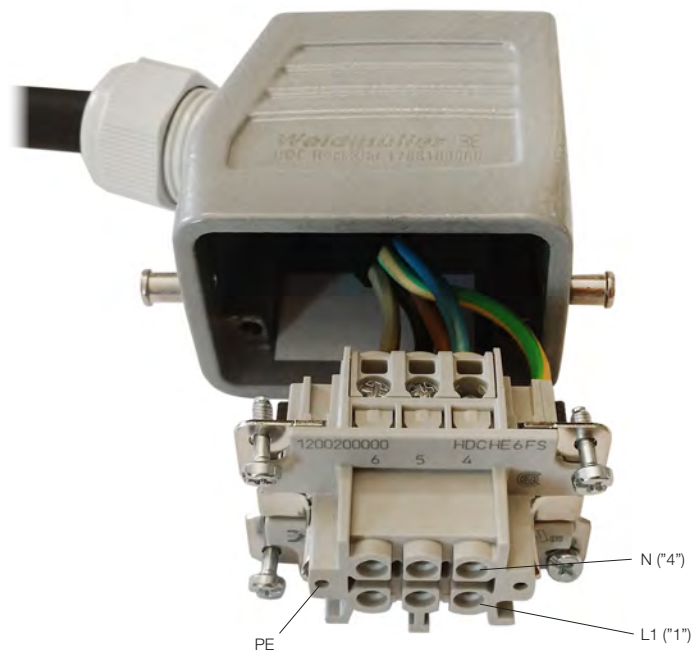

7.3 Frequency inverter – using the front panel keypad

Please take a moment to familiarize yourself with the keypad layout shown in the figure below. The display is used in programming the inverter's parameters, as well as monitoring specific parameter values during operation.

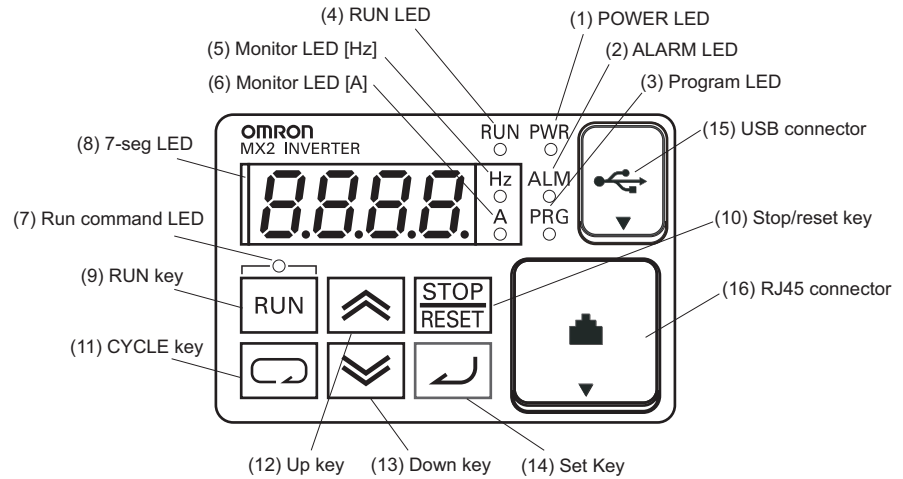

Items	Contents
(1) POWER LED	Turns ON (Green) while the inverter is powered up.
(2) ALARM LED	Turns ON (Red) when the inverter trips.
(3) Program LED	· Turns ON (Green) when the display shows changeable parameter. · Blinks when there is a mismatch in setting.
(4) RUN LED	Turns ON (Green) when the inverter is driving the motor.
(5) Monitor LED [Hz]	Turns ON (Green) when the displayed data is frequency related.
(6) Monitor LED [A]	Turns ON (Green) when the displayed data is current related.
(7) Run command LED	Turns ON (Green) when a Run command is set to the operator. (Run key is effective.)
(8) 7-seg LED	Shows each parameter, monitors etc.
(9) Run key	Makes inverter run.
(10) Stop/reset key	· Makes inverter decelerates to a stop. · Reset the inverter when it is in trip situation
(11) CYCLE key	· Go to the top of next function group, when a function mode is shown · Cancel the setting and return to the function code, when a data is shown · Moves the cursor to a digit left, when it is in digit-to-digit setting mode · Pressing for 1 second leads to display data of <i>d00 I</i> , regardless of current display.
(12) Up key	· Increase or decrease the data.
(13) Down key	· Pressing the both keys at the same time gives you the digit-to-digit edit.
(14) SET key	· Go to the data display mode when a function code is shown · Stores the data and go back to show the function code, when data is shown. · Moves the cursor to a digit right, when it is in digit-to-digit display mode
(15) USB connector	Connect USB connector (mini-B) for using PC communication
(16) RJ45 connector	Connect RJ45 jack for remote operator

Keys, modes and parameters

The purpose of the keypad is to provide a way to change modes and parameters. The term *function* applies to both monitoring modes and parameters. These are all accessible through *function codes* that are primary 4-character codes. The various functions are separated into related groups identifiable by the left-most character, as the table shows.

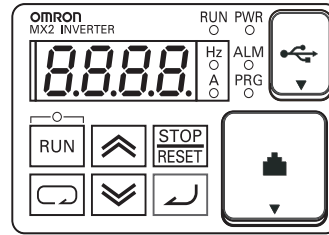

Function Group	Type (Category) of Function	Mode to Access	PRG LED Indicator
"d"	Monitoring functions	Monitor	○
"F"	Main profile parameters	Program	●
"A"	Standard functions	Program	●
"b"	Fine tuning functions	Program	●
"C"	Intelligent terminal functions	Program	●
"H"	Motor constant related functions	Program	●
"P"	Pulse train input, torque, Drive Programming, and communication related functions	Program	●
"U"	User selected parameters	Program	●
"E"	Error codes	–	–

Keypad navigation map

The inverter drives have many programmable functions and parameters. You need to access just a few items to perform the powerup test. The menu structure makes use of function codes and parameter codes to allow programming and monitoring with only a 4-digit display and keys and LEDs. So, it is important to become familiar with the basic navigation map of parameters and functions in the diagram below. You may later use this map as a reference.

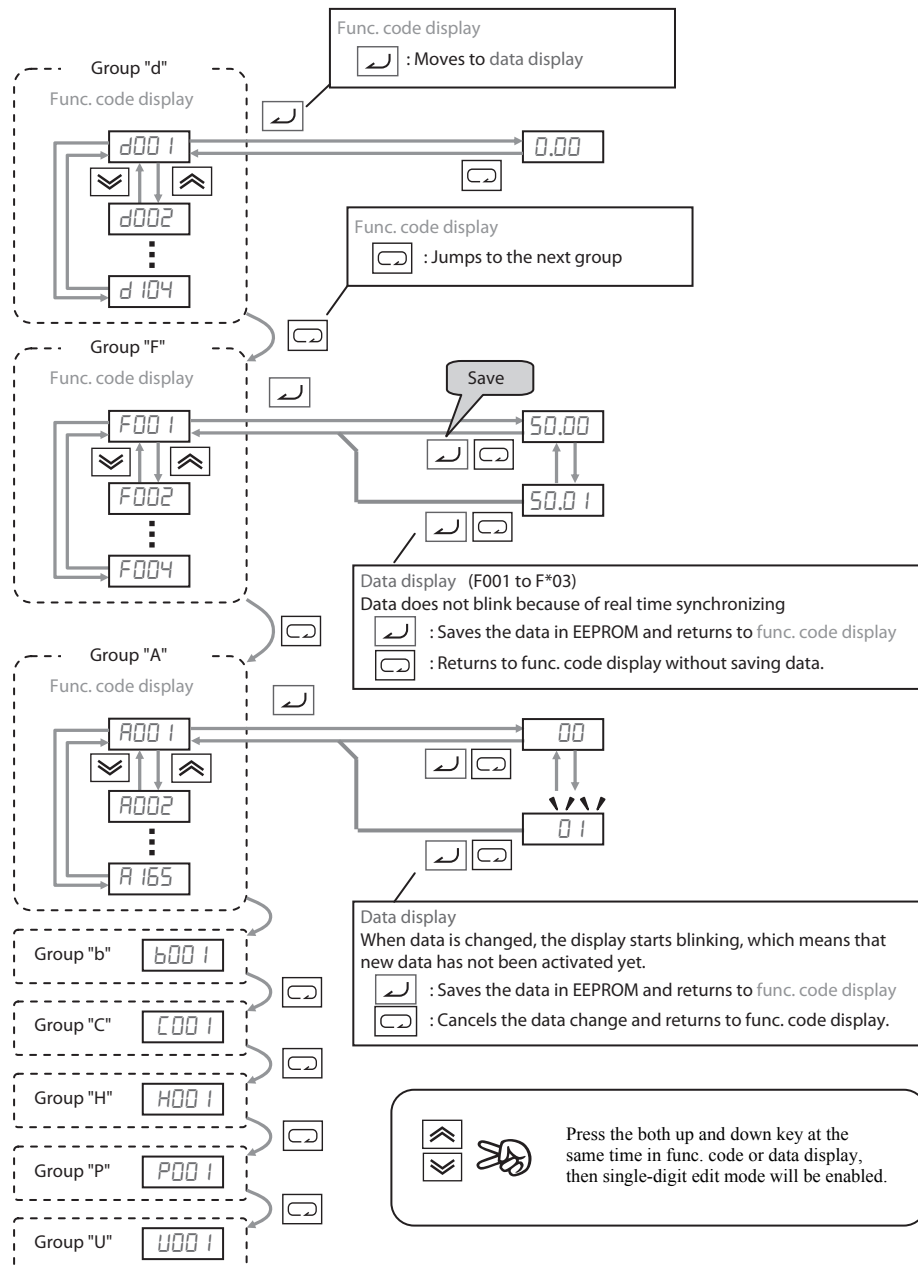

Note Pressing the ⏪ key will make the display go to the top of next function group, regardless the display contents. (e.g. A02 1 → ⏪ → b00 1)

[Setting example]

After power ON, changing from 0.00 display to change the b003 (carrier frequency) data.

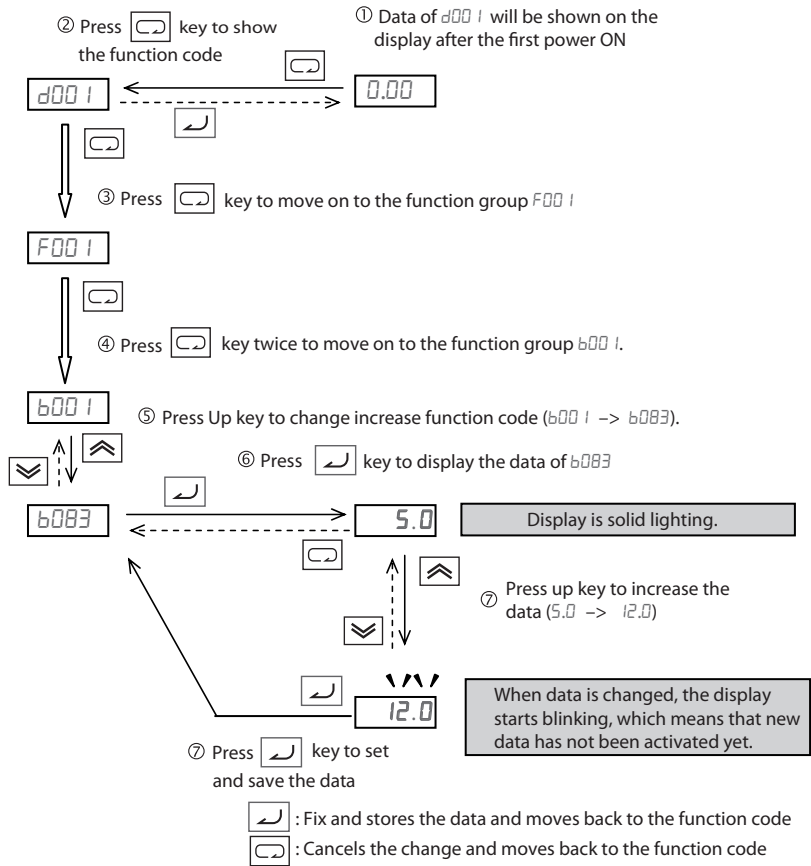

Note Function code **bxxx** are for monitor and not possible to change. Function codes **Fxxx** other than **FHHH** are reflected on the performance just after changing the data (before pressing [key] key), and there will be no blinking.

	When a function code is shown...	When a data is shown...
[key]	Move on to the next function group	Cancels the change and moves back to the function code
[key]	Move on to the data display	Fix and stores the data and moves back to the function code
[key]	Increase function code	Increase data value
[key]	Decrease function code	Decrease data value

Note Keep pressing for more than 1 second leads to d001 display, regardless the display situation. But note that the display will circulate while pressing the [key] key because of the original function of the key. (e.g. 100F -> 100A -> 100C >- 100b -> ... -> displays 00.05 after 1 second)

7.4 Setting of encoder (option)

Electric Mechchain Pro II may optionally be equipped with an encoder that reads the axle in the spindle limit switch. This makes it possible to set a lower stop position, as well as a further two stop/start positions along the stroke.

The positions are stored in a built in memory in the frequency converter and are not erased in case of power cuts. It is possible to adjust the height several times by following the same procedure. The stop/start position when moving upwards may be at the same height as for the downwards movement.

Please note: The encoder never replaces the end limit switches! It is only to be used as a complementary tool to facilitate for the operator to stop the lifting movement at pre-set positions.

Resetting the encoder (when changing/at first installation)

1. Use the joystick to drive Mechchain Pro II to the top position (the upper spindle limit switch stops the lifting movement).
2. Go to parameter P128 on the frequency converter, and set the value = 1.
3. Wait 10 seconds.
4. The encoder is now reset.

Setting the lower stop position

1. Use the joystick to drive Mechchain Pro II to the desired lower stop position.
2. Go to parameter D25 on the frequency converter and read the value (0-9999).
3. Go to parameter P129 and set the value = the value from D25.

Please note: Parameter P129 must be more than 0000 if the other positions are to be used. The function is deactivated by setting the value to = 0000.

Setting the stop/start position for an upward movement

Manual setting (alternative 1):

1. Use the joystick to drive Mechchain Pro II to the desired stop position.
2. Activate the emergency stop.
3. Press the joystick upwards for 20 seconds.
4. Release the joystick and reset the emergency stop.

Via the frequency converter (alternative 2):

1. Use the joystick to drive Mechchain Pro II to the desired stop position.
2. Go to parameter D25 on the frequency converter and read the value (0-9999).
3. Go to parameter P131 and set the value = the value from D25.

Setting the stop/start position for a downward movement

Manual setting (alternative 1):

1. Use the joystick to drive Mechchain Pro II to the desired stop position.
2. Activate the emergency stop.
3. Press the joystick downwards for 20 seconds.
4. Release the joystick and reset the emergency stop.

Via the frequency converter (alternative 2):

1. Use the joystick to drive Mechchain Pro II to the desired stop position.
2. Go to parameter D25 on the frequency converter and read the value (0-9999).
3. Go to parameter P130 and set the value = the value from D25.

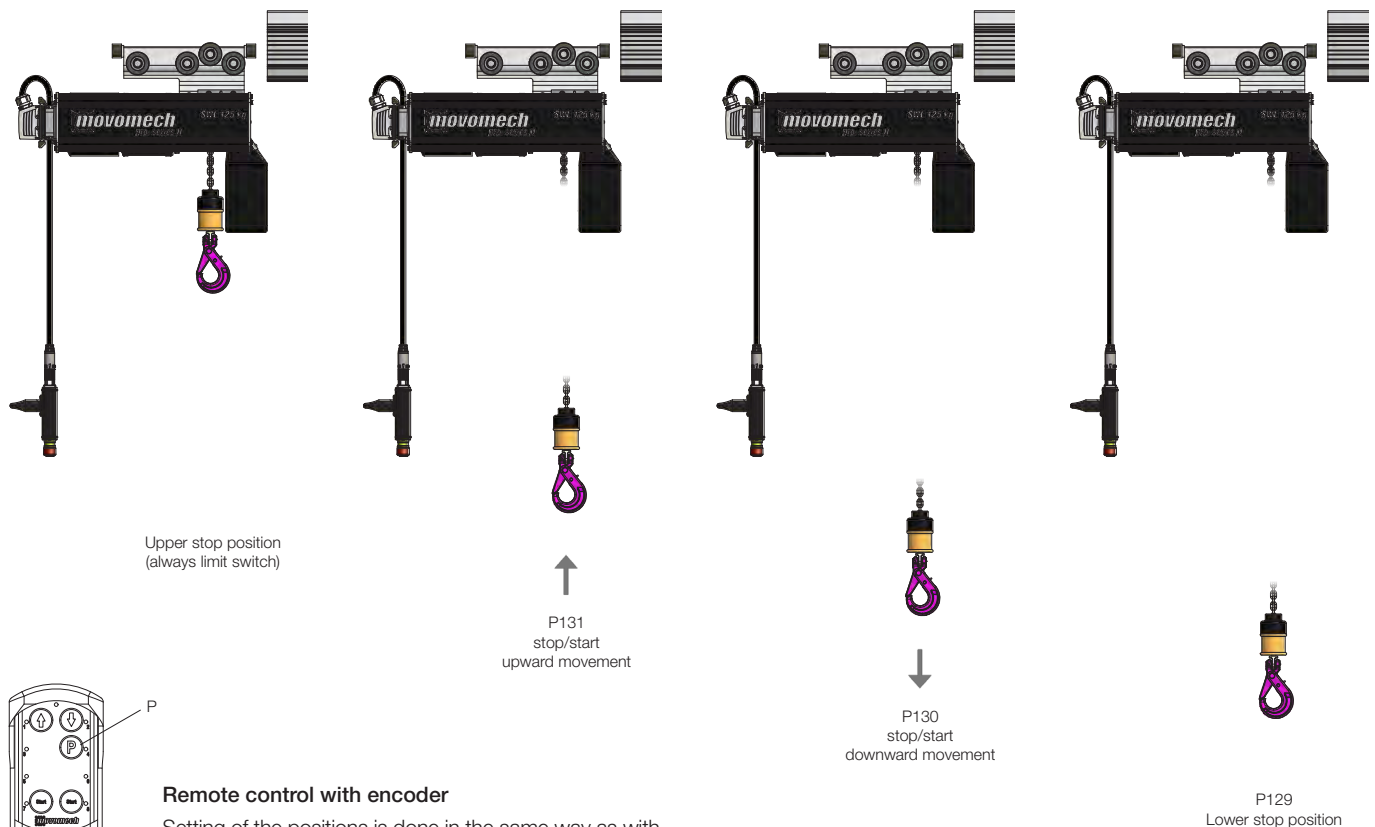

8. User instructions

Mechchain Pro II can advantageously be used in combination with a gripping tool for a smooth and ergonomic material handling.

The operation of Mechchain Pro II is largely dependent on its specific application:

- its configuration
- eventual gripper design and functionality
- characteristics and variability of the handled object
- the surrounding work environment
- intended work pace as well as usage frequency

A complete workstation, including Mechchain Pro II, must be accompanied by a specific operating instruction for the particular application, taking into account the mentioned factors.

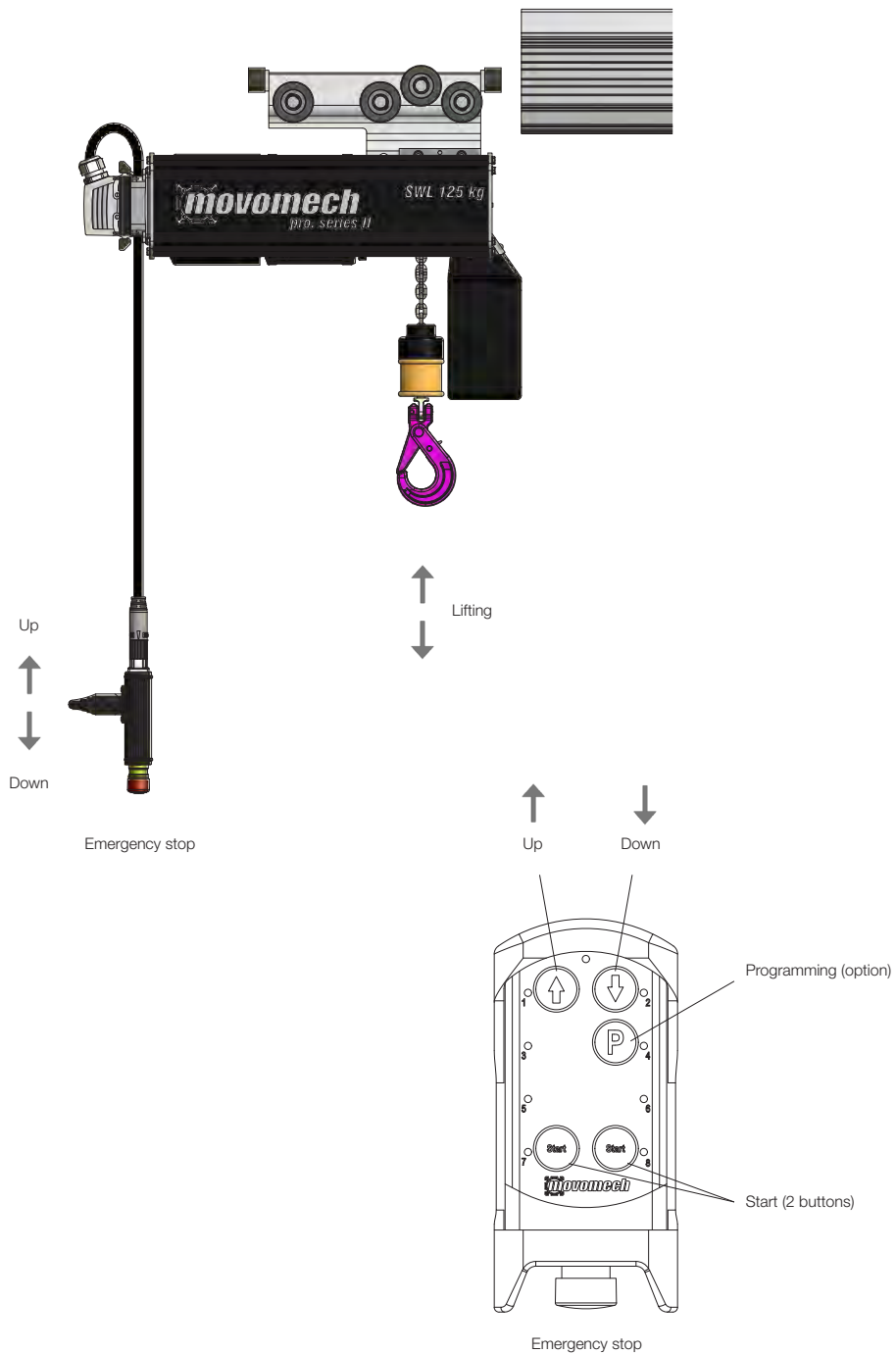

9. Service, maintenance & running

A general review and functional control tests are performed on a regular basis during commissioning.

All service and maintenance shall be recorded. The user should make sure that material for the purpose is easily available.

NOTE: Make sure that damaged components are replaced immediately in order to avoid possible personal and material damage.

Keep the equipment and area on and adjacent to the workplace cleaned. This is important for the comfort and well-being of personnel and facilitates service and maintenance. Dirt gives a clear indication of the equipment not being properly maintained, which may possibly affect the remaining guarantees on the equipment.

Maintenance safety instructions

The prescribed procedures and service intervals, including those concerning the replacement of parts/accessories, are described in the instruction manual and must be followed. Professionals are the only persons who are allowed to carry out such procedures.

Staff members with appropriate competence and authority are the only persons who are allowed to carry out mechanical and electrical repair and maintenance work. Unauthorised persons should be prohibited to work with machines and devices inside the equipment.

The equipment should be disconnected and secured against unintentional or unauthorised use, including reconnection, during all repair and maintenance work.

It should be confirmed that the equipment is free from voltage before any work on electric equipment is commenced.

Make sure that:

- moving parts are stationary and locked, and that
- moving parts cannot move accidentally during maintenance work.

Use safe and environmentally friendly maintenance products and spare parts!

Directions for work during operation

The user or the "authorised person" must, in each individual case, ensure that the work in question can be carried out without any risk of personal injury because of specific local conditions.

To prevent accidents, only approved and suitable tools and aids may be used during maintenance, adjustment and repair work.

Do not touch rotating parts. Maintain an adequate safe distance between yourself and the machinery to prevent clothes, limbs and hair from becoming caught.

Avoid the occurrence of naked flame, extreme heat (e.g. welding) and sparks in the presence of volatile cleaning materials and nearby inflammable or heat-sensitive materials (e.g. wood, plastics, oils, fats and electric equipment). This can result in fire hazard, harmful gases and damaged insulation.

Directions for work with electric equipment

Use only original fuses with the appropriate rating. The equipment should be stopped immediately on discovery of faults related to the electric power supply.

Defect fuses must not be repaired or bypassed and should only be replaced with fuses of the same kind.

Work on electric equipment and electric components or parts must be carried out by an electrician or authorised staff in accordance with current electric safety regulations.

The parts of the equipment on which inspection, maintenance, and repair work is to be carried out should be disconnected from the power supply.

The electrical equipment should be inspected regularly. Deficiencies, such as loose connections, should be rectified without delay.

When it is necessary to work with live parts, a second member of staff, whose responsibility it is to activate the emergency stop and deactivate the main switch in case of an emergency, should be called in. Isolate the work area with a red/white chain or tape and warning signs. Use only voltage-insulated tools.

Electric connectors must be free of voltage (exemptions include socket-outlets, unless safety precautions state that these are dangerous to be in contact with) before they are disconnected or connected.



Keep the equipment and area on and adjacent to the workplace cleaned.

9.1 Recommended spare parts / wear parts

74xxxx Mechchain Pro II base model				
#	Article nr.	Designation		Quantity
2	742909	Worm gear motor 0.37 kW	R	1
6	731019	Chain sprocket	R	1
9	731023	Chain guide	R	1
18	731428	Guiding for chain sprocket	R	1

Base model	742954	742912	743020
For profile -	LHB	PHB1 / AHB1.1-2	Universal

731016 Trolley Mechchain LHB				
#	Article nr.	Designation		Quantity
2	730206	Wheel LHB	R	8

742911 Trolley Mechchain AHB				
#	Article nr.	Designation		Quantity
3	730324	Wheel AHB1.1-2	R	8

7430xx Standard hook 63-80-125 kg				
#	Article nr.	Designation		Quantity
1	731419	Lifting chain Ø4x12	S	5,5
2	731418	Standard hook	R	1

7430xx Safety hook 63-80-125 kg				
#	Article nr.	Designation		Quantity
1	731419	Lifting chain Ø4x12	S	5,5
2	731637	Safety hook	R	1

743004 Safety hook 225 kg				
#	Article nr.	Designation		Quantity
1	731419	Lifting chain Ø4x12	S	8
2	742934	Safety hook, 2 part	R	1

742934 Safety hook, 2 part				
#	Article nr.	Designation		Quantity
1	730587	Ball bearing	R	2
2	742938	Chain sprocket for bearing	R	1

742921 Electrical cabinet				
#	Article nr.	Designation		Quantity
1	742922	Frequency inverter 0,4 kW	R*	1
2	742917	Rotary limit switch	R	1
3	742923	EMC filter	R	1
4	742926	Brake resistor	R	1

* When ordering as spare part, specify the lifter's serial number for the loading of correct parameters and program.

742195 Control unit with emergency stop				
#	Article nr.	Designation		Quantity
1	732307	Joystick JC100	R	1
2	731740	Emergency stop assembly	R	1

742196 Control unit with protection + emergency stop				
#	Article nr.	Designation		Quantity
1	732307	Joystick JC100	R	1
2	731740	Emergency stop assembly	R	1

742197 Control unit with protection + em. stop + handle				
#	Article nr.	Designation		Quantity
1	742946	Joystick JC100, worked	R	1
2	731740	Emergency stop assembly	R	1

742192 Control unit with emergency stop				
#	Article nr.	Designation		Quantity
5	731740	Emergency stop assembly	R	1
6	732307	Joystick JC100	R	1

742194 Control unit with protection + emergency stop				
#	Article nr.	Designation		Quantity
5	731740	Emergency stop assembly	R	1
6	732307	Joystick JC100	R	1

























































742240 Control unit external emergency stop				
#	Article nr.	Designation		Quantity
1	742191	Control unit	(R)	1
2	740457	Emergency stop, complete	R	1

742241 Control unit w. protection + ext. emergency stop				
#	Article nr.	Designation		Quantity
1	742193	Control unit with protection	(R)	1
2	740457	Emergency stop, complete	R	1

742191 Control unit				
#	Article nr.	Designation		Quantity
4	732307	Joystick JC100	R	1

742193 Control unit with protection				
#	Article nr.	Designation		Quantity
4	732307	Joystick JC100	R	1

9.2 Service record – Mechchain Pro II

ID: Service by:	Client/ place: Date:			The service record shall be archived by the client/user.	1/1	
 Visual inspection, examine whether the product exhibits damages				* If applicable. Tests are to be performed with unloaded gripper tool. The service must be performed considering the maintenance safety instruction.		
 Auditory inspection, examine whether the product exhibits discordant sound						
 Physical inspection, examine whether the product exhibits damages						
 Mechanical inspection, examine whether the product exhibits decomposition, instruments is needed						
No	Product	Inspection	Interval in months when 1-3 shifts	Interval in months when >3 shifts	Inspector Dept. / Sign.	Comment
1	<u>Motor unit</u>	    General overview.	3	2		
1.1	Fasteners	  	3	2		
1.2	Motor	    Check if gear box is leaking. Check cabling and connections. Test: Drive the hoist up and down, the motor must respond instantly when joystick is affected. Run both top speed and slow speed.	3	2		
1.3	Chain wheel	 	→	→		See section: 9.3
2	<u>Electric cabinet</u>	    General overview.	3	2		
2.1	Fasteners	  	3	2		
2.2	Cabling	   Check cabling and connections.	3	2		
2.3	Limit switch unit	    Test: Drive the hoist up and down, the motor shall stop automatically in upper and lower positions. NOTE! The hoist motion must not be limited by any mechanical obstructions!	Daily	Daily		See section: 9.6
3	<u>Trolley</u>	    General overview.	3	2		
3.1	Fasteners	  	3	2		
3.2	Wheels	    Check that the trolley runs quietly and easily along the entire runway.	3	2		
4	<u>Chain</u>	    General overview.	→	→		See section: 9.3-9.4
5	<u>Chain hook</u>	    General overview.	2	1		See section: 9.5
6	<u>Control units & emergency stop</u>	  General overview.	3	2		
6.1	Joystick/transmitter	  Test: Drive the hoist up and down, the motor must respond instantly when joystick/transmitter is affected. Run both top speed and creep rate.	Daily	Daily		
6.2	Emergency stop	  Test: Drive the hoist up and down, activate the emergency stop button, the hoist must stop instantly when the button is activated. The button must remain activated after being affected (reset by turning button).	Daily	Daily		

9.3 Chain and chain sprocket

Chain drive

The life of the chain depends on its lubrication. The environment and operating conditions affect examination and maintenance intervals. Maintenance of the chain includes regularly checking for wear and lubricating the chain *every 100 operating hours*. The quality of the lubrication can be determined during the daily inspection of the chain.

- Re-lubricate or change lubrication if needed.
- Dirty chains must be cleaned before lubrication.
- Lubrication must be carried out in the unloaded state so that the lubricant penetrates the bearing surfaces of the chain.
- Use dry lubricants (dry film lubricant) in environments with increased wear (sanding dust, sand, etc).

Inspection of the chain

Before the chain is condemned, the following must be taken into account:

- chain wear
- surface defects
- corrosion

Measuring chain wear

The elongation of the chain's nominal length is a direct measurement of chain wears. Thus, amount of wear can be determined through measuring the length according to the following instructions.

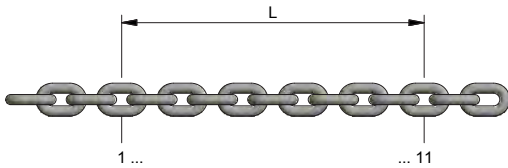

Measured length 'L' in mm.

The nominal chain length over 11 links is 140 mm.

The result of measuring the chain length over 11 links as shown in the illustration may not exceed 143 mm.

As a general rule the chain is worn-out and should be replaced when the elongation expressed as a percentage reaches 2%.

Surface defects and corrosion

If there are surface defects or corrosion, the chain must be replaced. Note! Corrosion reduces the lifting capacity of the chain appreciably and may cause it to break.

Replacing chain and chain sprocket

The chain should be replaced in its entirety for the following reasons:

- The costs associated with standstills often exceed those associated with chain replacement.

If the chain is to be changed as a result of wear or for any other reason, you must ensure that the new chain is lubricated after installation.

- Normally, the chain sprocket(s) must be changed at the same time as the chain.

Personal safety regulations

The following precautionary actions must be taken before the chain is disconnected and removed from a transmission in connection with a chain replacement or repairs:

- Always disconnect the power source from the lifter and offload all other equipment from the lifter.
- Always use protective glasses.
- Always use appropriate protective clothing, gloves and work shoes.
- Ensure that all tools are in good condition.
- Always loosen chucking devices.
- Support the chain in order to avoid sudden collapse of chain or other components.
- Never try to dismantle or connect a chain without being fully aware of the lifter's construction and functions.
- Never reuse a damaged chain or chain component.

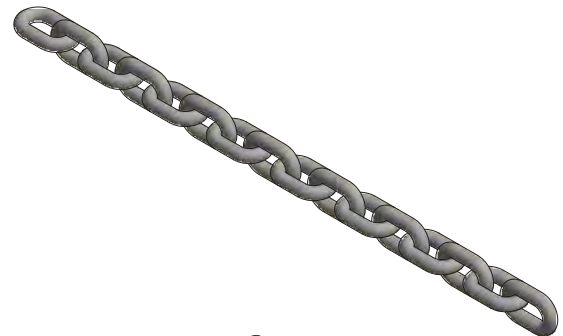

- The chain must be checked regularly and be lubricated every 100:re operating hours.
- Recommended lubricant: Mobil Pyrolube 830 (applied by brush)
- Normally, the chain sprocket(s) must be changed at the same time as the chain.

9.4 Replacement of chain

1. Read through the section Chain and chain sprocket.
2. Drive Mechchain Pro II to the top position.
3. Dismount the hook.
4. On base model 225 kg, the chain is then dismantled from the chain bracket.
5. Measure the length of the protruding chain.
6. Remove the spindle limit switch. Be careful not to change the position of the axle. (Fix it possibly with tape.)
7. Dismount the chain collector and end stop (the mechanical end stop on the chain).
8. Attach an open chain link (like a C) on the last link.
9. Attach a new chain in the open link.
10. Drive slowly the new chain through until the open link and the old chain have come out.
If a rattling noise is detected when the chain is being driven through, it can be a sign of wear on the chain sprocket or chain guide. These are replaced by RonI service department.
11. Mount the end stop and chain collector.
12. Drive the chain to the initial protruding length while lubricating the chain.
13. Remount the spindle limit switch and hook.
14. On base model 225 kg, fasten the chain in the chain bracket.
15. Test drive Mechchain Pro II and verify that the upper and lower limit switches function correctly.

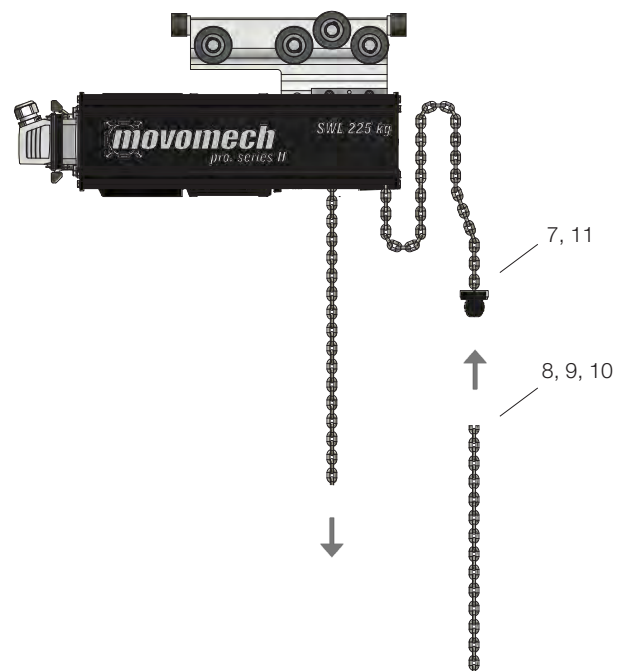
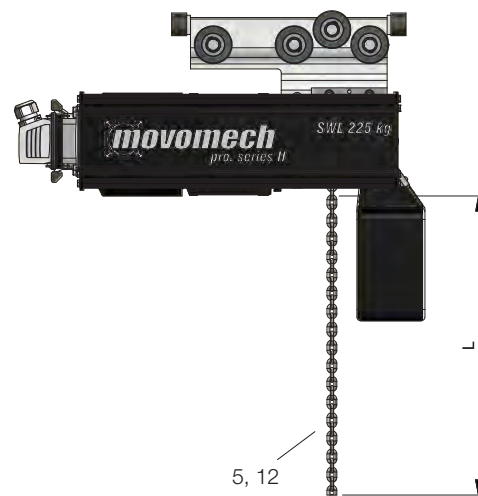
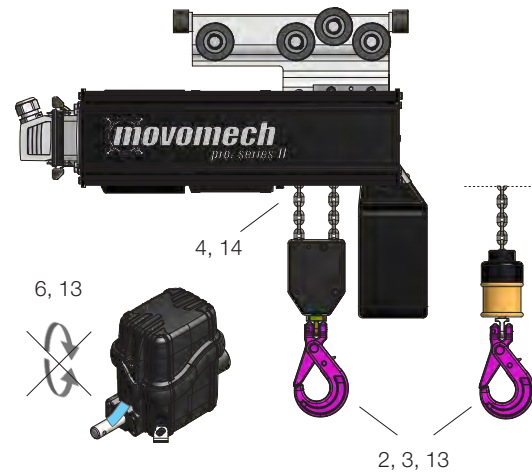

9.5 Check of hook wear

Checking the hook

Check the hook for cracks, distortion and wear. If the guide values below for the hook opening E and material thickness F are not complied with, the hook must be replaced.

Checking the hook latch

Verify the hook latch function G and check for distortion and wear.

Checking the hook bearing

Test the hook bearing H by rotating a suspended load. If any stiffness or binding is observed, the entire hook must be replaced.

When necessary, open the cover and lubricate the bearing with appropriate bearing grease.

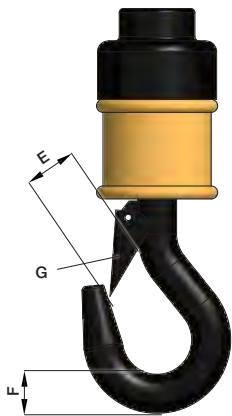

731418

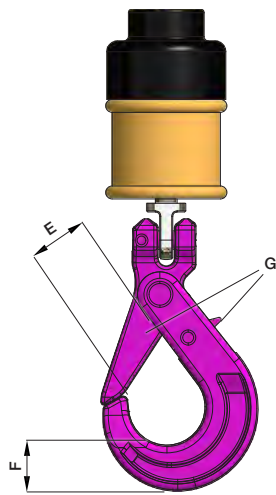

731637

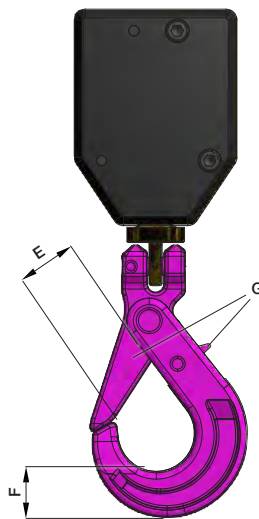

742934

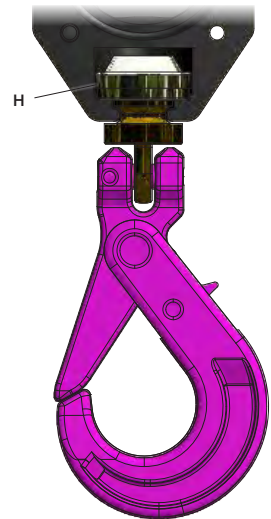

Hook		731418	731637 / 742934
Max. opening E	mm	26,4	33,0
Min. thickness F	mm	18,1	21,5

9.6 Adjustment of spindle limit switch

In case of replacing the chain, or such, the setting of the spindle limit position may be affected, which not only changes the upper and lower end limits and the useful length of stroke, but also runs the risk of the Mechchain Pro II striking the stroke limit mechanically (Z0 & Z7).

1. Run Mechchain Pro II to an upper stop position Z2 with 300 mm between the centre of the hook and the underside of the electric cabinet.
2. Turn screw 2 anti-clockwise until the upper lug strikes the switch (a clicking sound is heard). The lug must strike the switch from the left side.
3. Lower the hook approx. 300 mm to Z3. Run it up at full speed, and check if it stops at the upper limit position Z1 > 270 mm from the electric cabinet. (Please note that $Z1 < Z2$ due to the slowing down.)
If the upper limit position is $Z1 < 270$ mm, then repeat step 3 and turn the screw further anti-clockwise until $Z1 > 270$ mm.
4. Starting at Z1, lower the hook to the lower stop position Z5, 40 mm before reaching the maximum stroke length SL. (The stroke length SL has some excess capacity; the hook must not be lowered all the way to the mechanical end position Z7.)
5. Turn screw 1 clockwise until the lower lug strikes the switch. The lug must strike the switch from the right side.

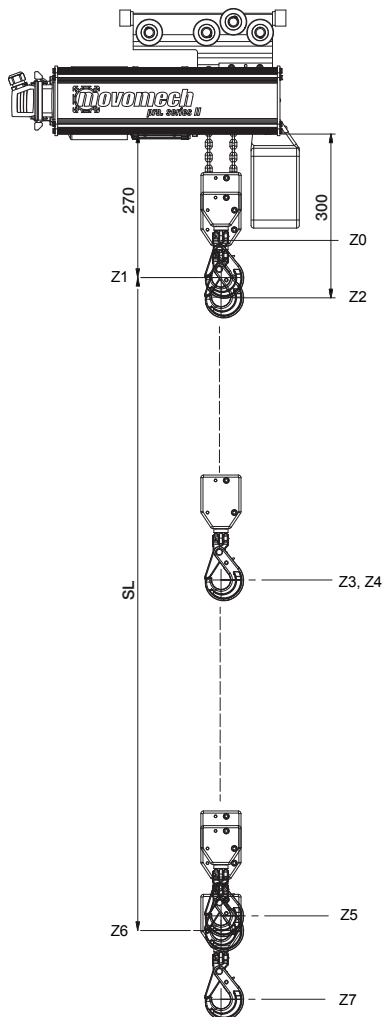

Position	Designation
Z0	Upper mechanical end position (must not be reached)
Z1	Upper end limit
Z2	Upper stop position
Z3	Upper test position
Z4	Lower test position
Z5	Lower stop position
Z6	Lower end limit
Z7	Lower mechanical end position (must not be reached)

6. Lower the hook approx. 300 mm to Z4. Run it down at full speed, and check if it stops at the lower limit position Z6 and check that the stroke length is correct.
7. Repeat step 6 and adjust the screw counter-clockwise if the stroke length is too long or too short, until the stroke length is correct.



9.7 Troubleshooting

Type of problem	Probable cause	Action
No hoisting motion up/down	The emergency stop is activated.	Check whether emergency stop for some reason has been activated, if no risk what so ever occurs when resetting the stop. Reset emergency stop.
	The hoist is exposed to mechanical obstacle.	Check whether some part of the lifter or tool including any object, are stuck in other equipment. Remove mechanical obstacle.
	Power failure.	Check whether there is a power supply failure, some procedure may be performed by authorized maintenance staff. Reset the power supply.
	Defective control unit.	Check whether the lifter has power, inspect the control unit, some procedure may be performed by authorized maintenance staff. Repair control unit.
	The hoist is in its uppermost position.	Lower the load.
	The hoist is in its lowest position.	Raise the load.
Incorrect operating range	Equipment serving as vertical working range limit is out of position.	Check whether the limit switch unit is damaged. Repair the limit switch unit.
Irregular or jerky hoisting motion up/down	The hoist is exposed to mechanical obstacle.	Check whether some part of the lifter or tool including any object is stuck to any equipment/interior. Remove mechanical obstacle.
	Chain sprocket and chain are worn out.	Replace chain wheel and chain.

9.8 Trip history and inverter status

We recommend that you first find the cause of the fault before clearing it. When a fault occurs, the inverter stores important performance data at the moment of the fault.

To access the data, use the monitor function (dxxx) and select d081: details about the present fault. The previous 5 faults are stored in d082 to d086. Each error shifts d081-d085 to d082-d086, and writes the new error to d081.

The following monitor menu map shows how to access the error codes. When fault(s) exist, you can review their details by first selecting the proper function: d081 is the most recent, and d086 is the oldest.

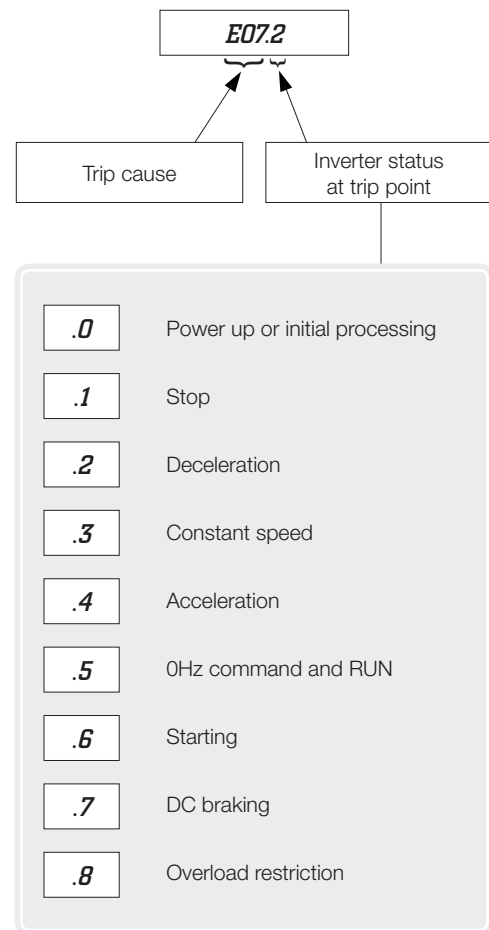
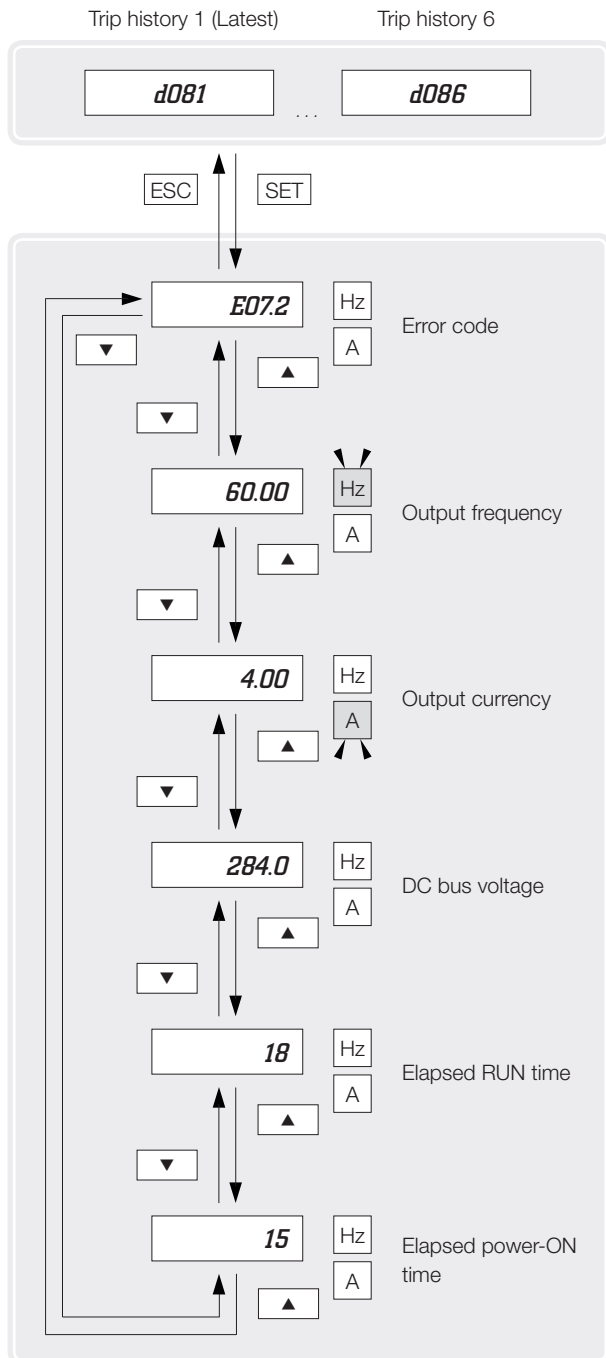

- Note: Indicated inverter status could be different from actual inverter behaviour.
E.g. When PID operation or frequency given by analogue signal, although it seems constant speed, acceleration and deceleration could be repeated in very short cycle.

Error code	Name	Cause(s)
E01	Over-current event while at constant speed	The inverter output was short-circuited, or the motor shaft is locked or has a heavy load. These conditions cause excessive current for the inverter, so the inverter output is turned OFF. The dual-voltage motor is wired incorrectly.
E02	Over-current event during deceleration	
E03	Over-current event during acceleration	
E04	Over-current event during other conditions	
E05	Motor overload protection	When a motor overload is detected by the electronic thermal function, the inverter trips and turns OFF its output. Check that the thermal model is properly set in parameter b0 12, b0 13, b9 10, b9 11 and b9 12. Check if the application can accept softer acceleration rates to minimize peak currents F002/F202/A092/A292). Check if motor parameters are not correctly set (H020 to H034 or H005), depending in motor control method (A044/A244).
E06	Braking resistor overload protection	When the BRD operation rate exceeds the setting of "b090", this protective function shuts off the inverter output and displays the error code.
E07	Over-voltage protection	When the DC bus voltage exceeds a threshold, due to regenerative energy from the motor.
E08	EEPROM error	When the built-in EEPROM memory has problems due to noise or excessive temperature, the inverter trips and turns OFF its output to the motor.
E09	Under-voltage error	A decrease of internal DC bus voltage below a threshold results in a control circuit fault. This condition can also generate excessive motor heat or cause low torque. The inverter trips and turns OFF its output.
E10	Current detection error	If an error occurs in the internal current detection system, the inverter will shut off its output and display the error code.
E11	CPU error	A malfunction in the built-in CPU has occurred, so the inverter trips and turns OFF its output to the motor.
E12	External trip	A signal on an intelligent input terminal configured as EXT has occurred. The inverter trips and turns OFF the output to the motor.
E13	USP	When the "Unattended start protection" (USP) is enabled, an error occurred when power is applied while a run signal is present. The inverter trips and does not go into "Run mode" until the error is cleared.
E14	Ground fault	The inverter is protected by the detection of ground faults between the inverter output and the motor upon during powerup tests. This feature protects the inverter, and does not protect humans.
E15	Input over-voltage	The inverter tests for input over-voltage after the inverter has been in "Stop mode" for 100 seconds. If an over-voltage condition exists, the inverter enters a fault state. After the fault is cleared, the inverter can enter "Run mode" again.
E21	Inverter thermal trip	When the inverter internal temperature is above the threshold, the thermal sensor in the inverter module detects the excessive temperature of the power devices and trips, turning the inverter output OFF.
E22	CPU communication error	When communication between two CPU fails, inverter trips and displays the error code.
E25	Main circuit error (*3)	The inverter will trip if the power supply establishment is not recognized because of a mal- function due to noise or damage to the main circuit element.
E30	Driver error	If instantaneous overcurrent occurs the Inverter will shut off IGBT's output to protect the main circuit element. After tripping due this protective function the inverter cannot retry the operation.
E35	Thermistor	When a thermistor is connected to terminals [5] and [L] and the inverter has sensed the temperature is too high, the inverter trips and turns OFF the output.
E36	Braking error	When "D 1" has been specified for the "Brake control selection" (b 120), the inverter will trip if it cannot receive the braking confirmation signal within the "Brake wait time for confirmation" (b 124) after the output of the brake release signal. Or when the output current doesn't reach the brake release current (b 126) during the brake wait time for release (b 121).
E37	Safe stop	Safe stop signal is given.*
E38	Low-speed overload protection	If overload occurs during the motor operation at a very low speed, the inverter will detect the overload and shut off the inverter output.
E40	Operator connection	When the connection between inverter and operator keypad failed, inverter trips and displays the error code.
E41	Modbus communication error	When "trip" is selected (C076=00) as a behavior in case of communication error, inverter trips when timeout happens.
E43	Drive programming invalid instruction	The program stored in inverter memory has been destroyed, or the PRG terminal was turned on without a program downloaded to the inverter.
E44	Drive programming nesting count error	Subroutines, if-statement, or for-next loop are nested in more than eight layers
E45	Drive programming instruction error	Inverter found the command which cannot be executed.
E50-E59	Drive programming user trip (0 to 9)	When user-defined trip happens, inverter trips and displays the error code.
E60-E69	Option errors (error in connected option board, the meanings change upon the connected option).	These errors are reserved for the option board. Each option board can show the errors for a different meaning. To check the specific meaning, please refer to the corresponding option board user manual and documentation.
E80	Encoder disconnection	If the encoder wiring is disconnected, an encoder connection error is detected, the encoder fails, or an encoder that does not support line driver output is used, the inverter will shut off its output and display the error code shown on the right.
E81	Excessive speed	If the motor speed rises to "maximum frequency (A004) x overspeed error detection level (P026)" or more, the inverter will shut off its output and display the error code shown on the right.
E83	Positioning range error	If current position exceeds the position range specification (P072-P073), the inverter will shut off its output and display the error code.

* E37.X only can be reset by digital input (18: RS).

10. EC certificate

EC declaration of conformity of the machinery

TRANSLATION
(according to 2006/42/EC, annex 2A)

Manufacturer

Representative for documentation
Representative for documentation

hereby declares that the machinery

Designation
Mechchain Pro II

Designation

Machine type
Chain hoist

Version
63, 80, 125, 225

complies to all applicable regulations in

Machinery Directive 2006/42/EC

EMC Directive 2014/30/EU

and that standards and/or technical specifications as described below are applied.

Machinery Directive
SS-EN-ISO 12100:2010

EMC Directive

Low Voltage Directive
IEC 60204-32
IEC 60204-1

Place: Kristianstad

Date: 2017-07-01



11. Revisions

Revision list

Edition	#	Designation	Pages
2016-05-01	0	First edition	-
2016-09-01	1	Updated electric drawings and parameter lists	26-31
2017-02-01	2	Updated recommended grease, added section Frequency converter – using the front panel keypad	42, 33-36
2017-03-01	3	Updated EC certificate	49
2018-02-15	4	Updated EC certificate	49