

PLACE
SERIAL
NUMBER
LABEL
HERE

LIFT-O-FLEX Squeeze-O-Turn LIFTER

USER MANUAL

DOCUMENT ID: 01022018

Have Questions?

We're here for you.



+1 866 543 8635
+1 704 847 2464



info@roni.com
www.roni.com



LIFT-O-FLEX

MOBI-Crane  Voyager



RONI
8001 Tower Point Drive
Charlotte, NC 28227 USA

BEFORE YOU BEGIN



READ

It is important that you read and understand this complete manual prior to using your LIFT-O-FLEX® ergonomic handling equipment. If you have any questions, contact your dealer or Ronl.



+1 866 543 8635
+1 704 847 2464



info@roni.com
www.roni.com



8001 Tower Point Drive
Charlotte, NC 28227 USA

SPECIAL NOTES

The appearance of your LIFT-O-FLEX® lifter and the accompanying attachments may differ from the images displayed in this manual due to the custom nature of this equipment.

LIFT-O-FLEX® is a registered trademark of Ronl, Charlotte, North Carolina.

“Where **Ergonomics** make
Economic sense.”

TABLE OF CONTENTS

1. DESCRIPTION	4
1.1 OVERVIEW	
2. SAFETY	4
2.1 STORAGE AND TRANSPORT	
2.2 MOVEMENT	
2.3 LOADING AND UNLOADING	
3. WARRANTY	5
4. ASSEMBLY INSTRUCTIONS	7
4.1 ASSEMBLY	
4.2 DISASSEMBLY	
5. OPERATING INSTRUCTIONS	9
5.1 USING THE LIFTER	
6. MAINTENANCE	10
6.1 GUIDELINES	
6.2 EVERYDAY	
6.3 MONTHLY	
6.4 YEARLY	
7. TROUBLESHOOTING	11
8. TECHNICAL SPECIFICATIONS	11
9. SCHEMATICS	12
9.1 WIRING DIAGRAM	
9.2 SPARE PARTS	
10. DECLARATION OF CONFORMITY	14



1. DESCRIPTION

1.1 OVERVIEW

The Squeeze-O-Turn (used in conjunction with the LIFT-O-FLEX Lifter) is provided to assist in handling loads that require squeezing and rotation. The unit provided will also help to prevent injuries as well as create safer working conditions for people that already suffer from injuries related to the moving of heavy objects. The lifter with Squeeze-O-Turn has been designed to be used in warehouses, industrial plants, institutional kitchens, drug stores, post offices, etc.

The Squeeze-O-Turn can be provided as either a complete unit on a new lifter or retrofitted to an existing lifter should your requirements change after your original lifter has been in service.

2. SAFETY

2.1 STORAGE AND TRANSPORT

When transporting and storing the Squeeze-O-Turn attached to a lifter, the power cable between the lifters power pack and the motor control box must be unplugged.

2.2 MOVEMENT

The lifter is only intended for in-door use and on flat solid surface.

2.3 LOADING AND UNLOADING

The user is responsible for ensuring that the lifter is loaded correctly. The maximum load must not be exceeded (max weight is as noted on the label regardless of weight capacity of lifter model).

The lifter and the end effector are not to be used for lifting people.

The operator is to be aware of the risk of injury that exists when raising or lowering the end effector. Avoid putting your arm through the handlebar when trying to get a hold of or pick up something from the end effector. The operator must always be aware of not holding his hands or other parts of his body under a hanging load.

Always lower the end effector to the lowest possible level above the floor before any transport of material or goods is attempted. The load is to be centered and be as close to the lift mast as possible in order to provide maximum stability. Be especially careful when passing over thresholds, cables and other obstacles on the floor. When working, always make sure you keep the end effector on the same level as the object you intend to lift.

3. WARRANTY

Limited Warranty

Ronl warrants this product to be free of defects in material and workmanship during the warranty period. Our warranty obligation is to provide a replacement for a defective original part if the part is covered by the warranty, after we receive a proper request from the warrantee (you) for warranty service.

Who may request service?

Only a warrantee may request service. You are the warrantee if you purchased the product from Ronl or from an authorized distributor and Ronl has been fully paid.

What is an “original part”?

An original part is a part used to make the product as shipped to the warrantee.

What is a “proper request”?

A request for warranty service is proper if Ronl receives: 1) a photocopy of the customer invoice that displays the shipping date and, 2) a written request for warranty service that includes your name and phone number. Requests may be sent using the following methods:



Mail

Ronl
8001 Tower Point Drive
Charlotte, NC 28227

Fax

Toll Free 1-866-543-9532
Direct 1-704-847-6739

Email

info@roni.com

What is covered under the warranty?

After Ronl receives your request for warranty service, an authorized representative will contact you to determine whether your claim is covered by the warranty. Before providing warranty service, Ronl may require you to send the entire product, or just the defective part(s), to its facility in Charlotte, North Carolina.

How long is the warranty period?

The warranty period for original dynamic components is one (1) year. For batteries, the warranty period is 30 days. The warranty period begins on the date when Ronl ships the product to the warrantee.

Warranty Evaluation

All parts sent back (freight paid by customer) to Ronl for warranty replacement and/or repair will be evaluated. Ronl will determine if the part is a warranty issue or if it has been damaged due to misuse or negligence. A written report will be issued detailing the investigation of the part and whether or not the part is classified as warranty.

What is not covered by this warranty?

1. Labor
2. Freight
3. Occurrence of any of the following, which will automatically void the warranty:
 - product misuse
 - negligent operation or repair
 - corrosion or use in corrosive environments
 - inadequate or improper maintenance
 - damage sustained during shipping
 - collisions or other incidental contacts causing damage to the product
 - unauthorized modifications: do not modify the product in any way without first receiving written authorization from Ronl as modifications(s) might make the product unsafe to use or could potentially cause excessive and/or abnormal wear



If a defective part is warranted, how will Ronl correct the problem?

Ronl will provide an appropriate replacement for any covered part. An authorized representative of Ronl will contact you to discuss your claim.

Warranty Procedure

In the event that a part is damaged or broken, please contact Ronl via phone or email to establish a dialogue to identify and diagnose the problem. Please have your lifter serial number available when you call or email.

(Located on the motor cover underneath the intermediate)

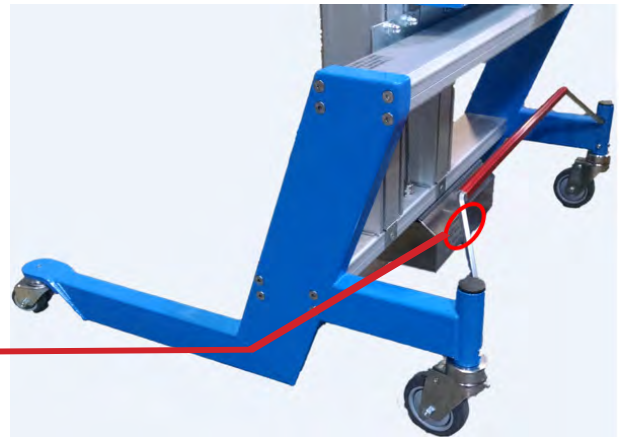

4. ASSEMBLY INSTRUCTIONS

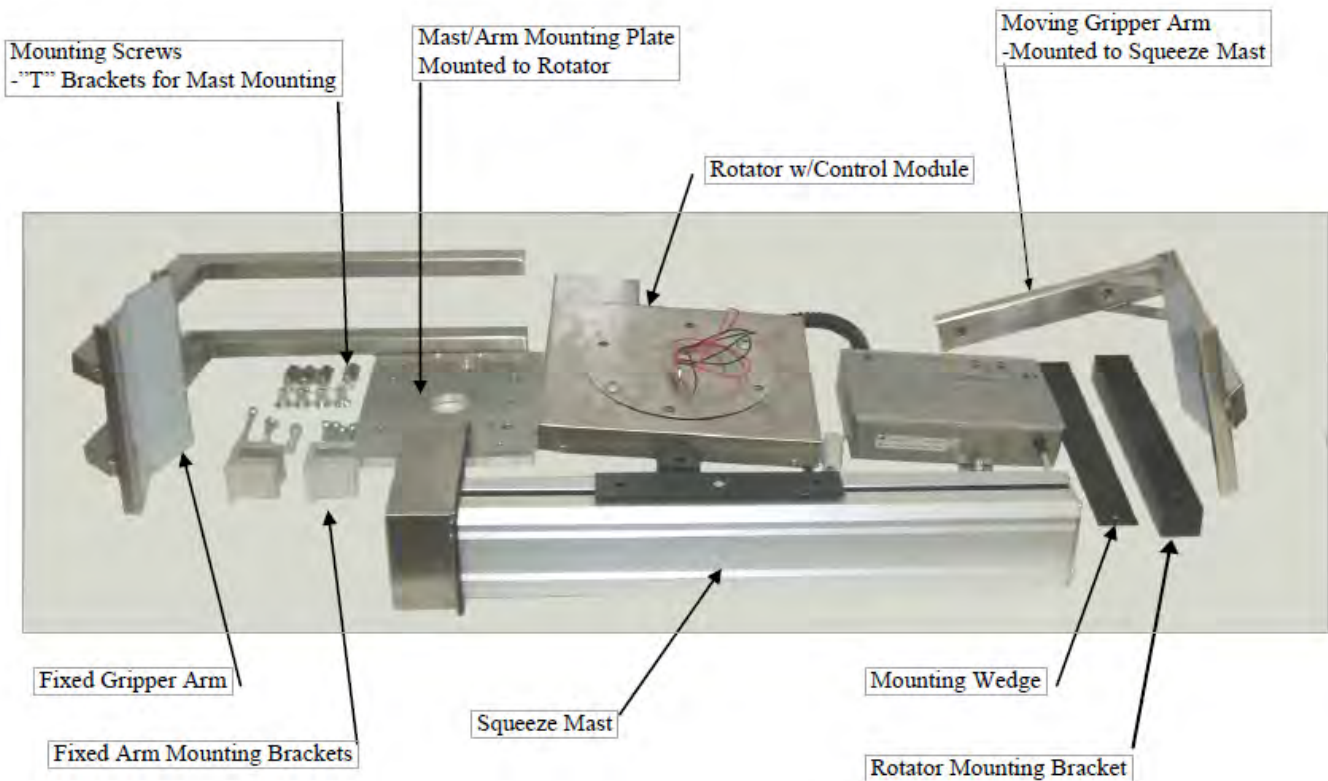

4.1 ASSEMBLY

Assembly Instructions

1. Undo the screws in the mast slide that are provided to hold the end-effector. (The screws that come with the lifter cannot be used, since they are too long). Lift the turn plate into place against the slide with the mounting wedge (if required) and position the accompanying spacer kit (if required) between the rotator and the mast slide. Insert and tighten the provided bolts that are supplied with the rotator.
2. Loosen the handlebar on the lifter and adjust to a comfortable position. Slide the control module into the slot in the back of the mast so that it comes above the power pack and tighten the screws. The cable carrier between the motor control box and the rotator should now be on the left-hand side of the mast. Plug the power cable from the rotator into the **“Power Out”** socket of the electronic power pack.
3. The lifter requires a cable carrier guide to be mounted on the mast (above the handlebar) to prevent the cable carrier from being bent backwards. Fit this item into the left hand slot in the back of the column and make it tight. On some installations, a retractable curly cord is supplied and does not require a cable carrier.
4. Next, mount the squeeze mast using the “T” brackets by inserting them into the track located on the back of the mast and screws as required and tighten. Connect wires to squeeze motor and replace motor cover.
5. Mount the four (4) fixed arm brackets using the bolts provided and leave loose. Slide the fixed arm into the brackets and position the arm so that the centerline of the load when squeezed is centered with the lift mast and tighten screws.
6. Mount the moving arm to the squeeze mast and tighten bolts.
7. When testing, be careful to ensure that the rotator does not interfere with the lift mast slide and that the cable carrier or curly cord is not too short or too long.

4.2 DISASSEMBLY

To disassemble the lifter, refer to directions above and reverse the order.

Disposal after useful life

When the lifter has provided many years of use and is ready to be disposed of, it should be recycled. The LIFT-O-FLEX®lifter is manufactured with materials that are recyclable. We have also selected recyclable gel-cell batteries over nickel-cadmium batteries for this purpose.

5. OPERATING INSTRUCTIONS

5.1 USING THE LIFTER

In order to prevent and avoid work injuries, it is important that the LIFT-O-FLEX is operated in a proper manner.

The rotate and squeeze functions are controlled from the control module. The control module functions vary depending of the end- effectors used together with the rotator.

A joystick controls the variable rotation speed of the rotator. The rotator has continuous rotation.

The squeeze and release buttons along with inhibit are located on the opposite side of the joystick. To release the load, the release and inhibit button must be pressed at the same time.

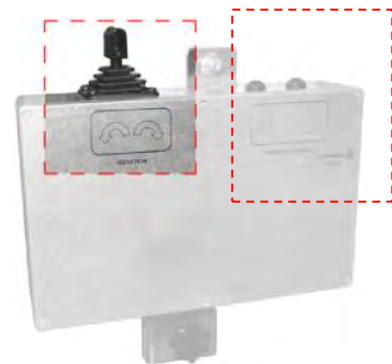

6. MAINTENANCE

6.1 GUIDELINES

In order for the lifter to function properly, it is important that maintenance is carried out in accordance with what is described below. The stated service intervals are applicable during normal use and charging once a day. Further use requires more frequent service intervals. After disassembly or assembly of the column or load carrier, a load test should be performed.

6.2 EVERYDAY

Clean the lifter by wiping it down only. Wipe the lifter dry after cleaning. Do not use hose or high-pressure jet as this may damage the electronics and the paint.

6.3 MONTHLY

Check that no abnormal noises have arisen in the motor and gear.

6.4 YEARLY

Electrical connections: Check all connections and repair any damaged or worn components. If necessary, replace with new parts.

Screws and nuts: Check that all screws and nuts are still tight.

Labels: check that the labels are secure and fully legible. They are there for your safety.

Plates and decals

Verify that the following plates and decals are attached and fully readable.

Plate / Decal	Description	Placement
Serial Number	Decal with serial number	On the top of the squeeze mast

7. TROUBLESHOOTING

The lifter is designed for safe and efficient operation, provided that routine maintenance is carried out in accordance with the instructions given. If problems arise, some guidance is provided below. If the problem persists after action has been taken, please contact a service technician or Ronl.

Symptom		To do	
1	Motor does not turn	A	Check the battery voltage which should be 24 volt.
		B	Maker sure the connections with motor are intact.
		C	Make sure the connections from the power pack to the motor control box are intact.
2	The rotator does not turn, or the squeeze mast does not move but the motor works	A	See above under heading Symptom, section 1.
		B	Check through the listed tasks in section 6 Maintenance.
3	The rotator/squeeze mast moves slowly	A	See above under heading Symptom, section 1.
4	The rotator/squeeze motor sounds strange while moving	A	Check through the listed tasks in section 6 Maintenance.

8. TECHNICAL SPECIFICATIONS

- Type: 12129C Squeeze-O-Turn
- Outer dimensions L x W x H 34 (1.33'') x 116 (4.56'') x 361 (14.21'')
- Rotation angle ~
- Dimension from floor to rotation Center point:
19000 Lifter 300 mm (11.81'')
- Max load 0 kg, depending of the maximum capacity of the lifter
- Weight of unit with Arms 50Kg(110-lbs)
- Intermittence 15% per 10 min, maximum load
- Voltage 4 V DC
- The measured square value for vibrations while squeezing does not exceed .5 m/s
- The sound level while rotating does not exceed 70 dB(A)
- An EU Declaration of Conformity accompanies each lifter
- CE-mark
- Material: aluminum and stainless steel, 18/8



9. SCHEMATICS / 9.1 WIRING DIAGRAM

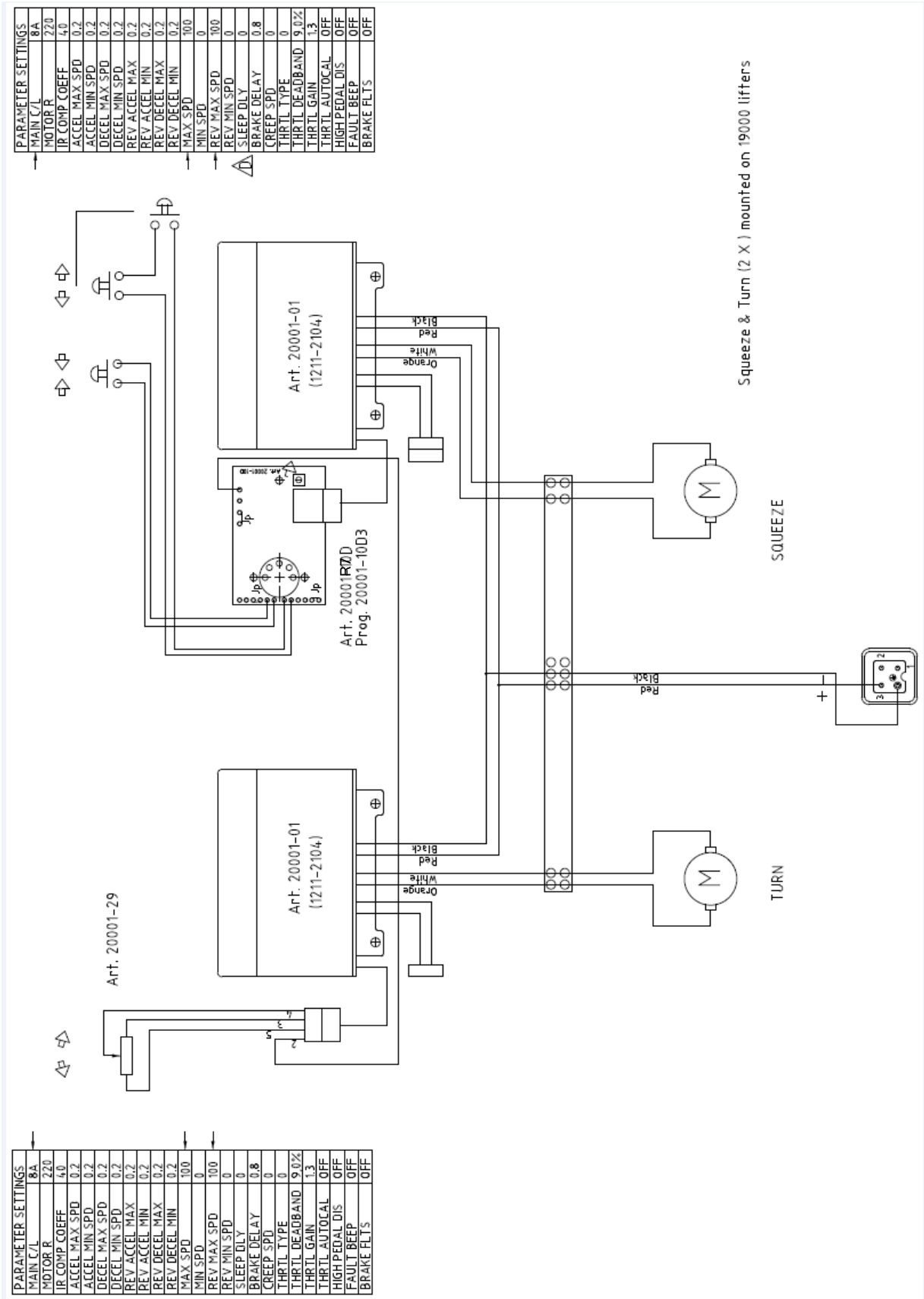

9.2 SPARE PARTS

Mast

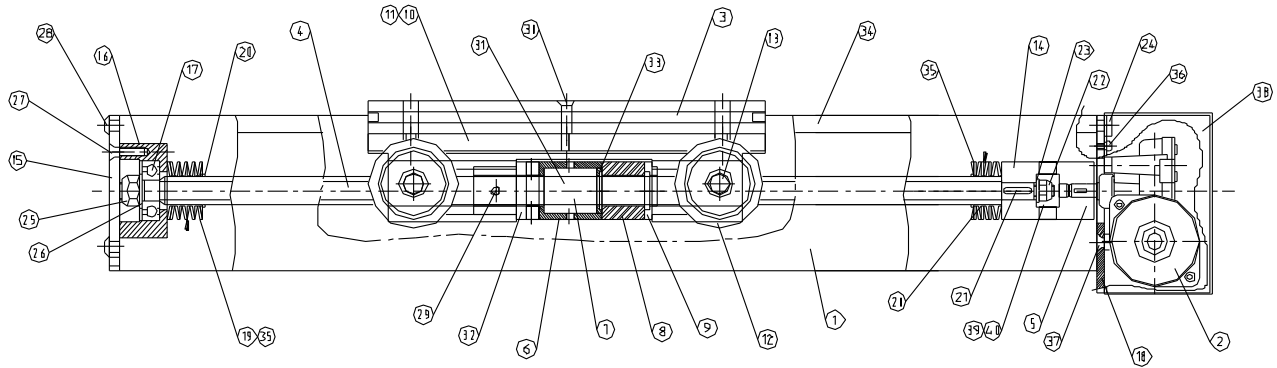

Item No.	Qty	Description	Part No.	Item No.	Qty	Description	Part No.
1	1	Column	19303-04	21	1	Key 20x 4	19151
2	1	Motor 403-936	17219	22	1	Lock Nut	Din 982 M8
3	1	Slide	19303-03	23	1	Washer	84 HB 200
4	1	Lead Screw	19303-02	24	4	Bolt	M8x21
5	1	Coupling	19120	25	1	Lock Nut	986 M1
6	1	Coupling-Lead Screw	19109	26	1	Washer	13 HB 201
7	1	Lead Screw Nut	19150	27	3	Bolt	M8x20 11.9
8	1	Spacer	19303-07	28	4	Bolt	M6x10
9	1	Spring Sleeve-Slide	19112	29	1	Lock Bolt	M6x30 11.9
10		N/A		30	1	Bolt	M6 x6
11	1	3/8 UNC Lock Bar	19125	31	4	Lock Bolt	T6S5 M6x6
12	4	Wheels	19115	32	1	Coupling	19110
13	4	Stub Shaft	19116	33	1	Spring Sleeve-Coupling	19111
14	1	Coupling	19121	34	2	Track Cover	19123
15	1	End-Cover	19113	35	14	Bevel Washer	19175
16	1	Bearing Holder	19114	36	4	Screw	M4 x 8 4.8
17	1	Ball Bearing	19102	37	3	Screw	6S M6x25 11.9
18	1	Motor Bracket	19303-05	38	1	Motor Cover	19303-06
19	4	Beveled Washer	19147	39	1	Insert	19222
20	2	Lock Ring	19107	40	1	Pipe Sleeve	19174



10. DECLARATION OF CONFORMITY

Manufacturer	Pronomic AB Box 5504 192 05 Sollentuna Sweden
Model	LIFT-O-FLEX - SQUEEZE-O-TURN
Serial Number	
Static load test	

Authorized to compile the technical file	Samuel Pierre, Pronomic AB, BOX 5504, 192 05 Sollentuna, Sweden
--	---

Applied EC directives:

2006/42/EC	Machinery Directive
2004/108/EC	EMC Directive

Applied standards:

SS-EN ISO 12100:2010	Safety of machinery - General principles for design - Risk assessment and risk reduction (ISO 12100:2010)
SS-EN 349+A1:2008	Safety of machinery - Minimum gaps to avoid crushing of parts of the human body

We hereby declare that the above-referenced machine, built and equipped with attachments included in this manual, is in conformity with the applicable conditions state in the directives and standards.

Sollentuna, 2015-12-07



.....

Joakim Stannow, Pronomic AB

The lifter has been modified and/or equipped with attachments as follows:

.....

.....

After modification a supplementary risk analysis has been performed and the machine is certified to be in conformity with the directives and standards above.

.....

Place, date

NOTES



info@roni.com



www.roni.com



+1 866 543 8635
+1 704 847 2464



8001 Tower Point Drive
Charlotte, NC 28227 USA



LIFT-O-FLEX

MOBI-Crane | *inovomech* | Voyager

RONI

8001 Tower Point Drive
Charlotte, NC 28227
USA

+1 866 543 8635
info@roni.com
www.roni.com

R on I reserves the right to change this information without further notice and holds no liability for printing errors in this content.

Copyright © 2016 R on I, All Rights Reserved.