

Vacuum lifter - Vacuhand V

Ergonomic lifting up to 200 kg!



Vacuhand is a vacuum lifter for loads between 5-200 kg. The lifter is designed for a two-hand grip. The lifting and lowering functions are regulated via a simple throttle which gives good ergonomics, safety and precision.

The large range of standardized grippers and accessories such as swivels, angular toggle joints, quick fasteners, extension parts and elbow joint handles make it easy to amend the lifter to suit and meet the needs and requirements.

The design aims at creating a minimum level of leakage, which implies secured performance and a lower energy consumption.



- ✓ *Effective*
- ✓ *Flexible*
- ✓ *Strong*

With controls on the handle it's easy to adjust the hovering settings with and without load.

Vacuhand allows easy handling of a wide range of items, from sacks and carton boxes to board material such as glass, metal sheets and doors.



movomech
Weightless applications

Vacuhand V

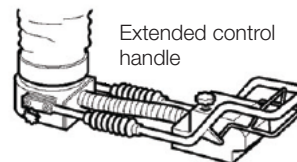
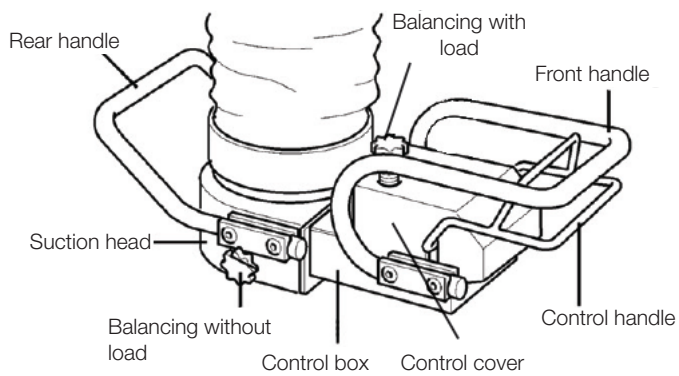
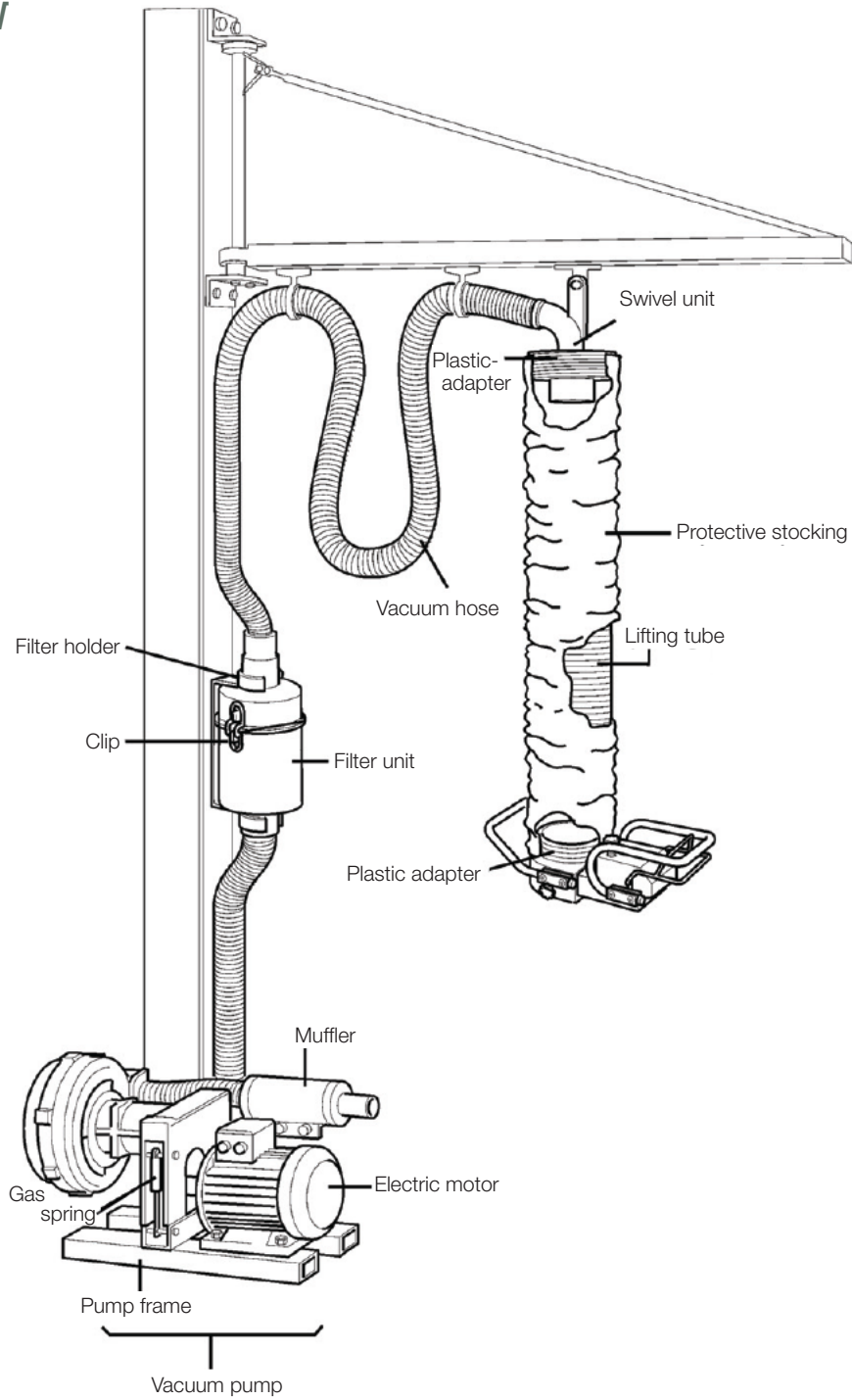

R on I, Inc.
8001 Tower Point Drive
Charlotte, NC 28227
USA

Phone +1 704 847 2464
Fax +1 704 847 6739
E-mail info@roni.com
Web www.roni.com

